

ALUMINUM TEE CONNECTORS

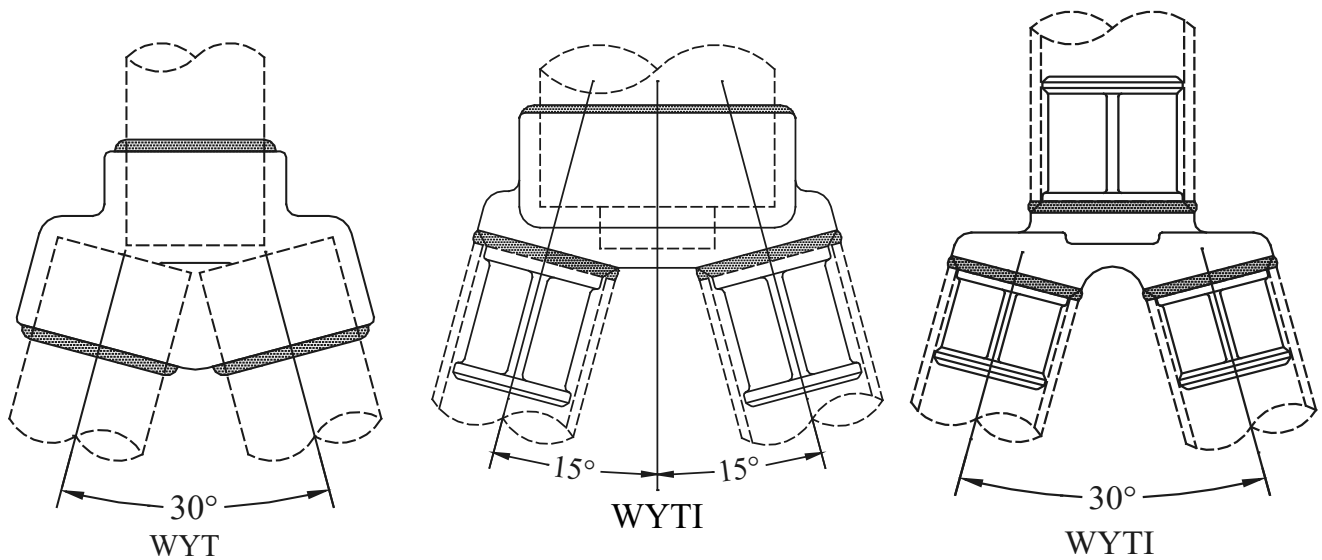

Variety of "Y" connectors available
Contact Factory for further information.

TYPE WTC

Straight Weldment
Pipe Main to Cable Tap

Casting: 356-T6 Aluminum

Aluminum alloy, straight weldment, tee for aluminum pipe main to cable tap connections.

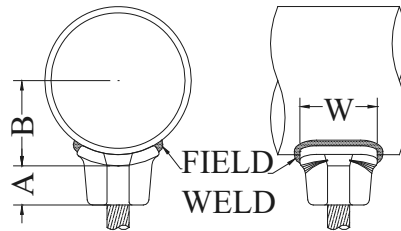

CATALOG NUMBER	CONDUCTOR RANGE			DIMENSIONS - INCHES			WEIGHT (POUNDS)
	PIPE MAIN	AAC TAP	ACSR TAP	A	B	W	
WTC-4916	1-1/4	336 MCM	----	1-1/16	1-3/16	2	0.25
WTC-5816	2	336.4-350 MCM	266 MCM	1-1/4	1-3/4	2-3/8	0.75
WTC-5821		550-556 MCM	----	1-1/4	1-3/4	2-3/8	0.75
WTC-6016	2-1/2	336.4-350 MCM	----	1-1/16	1-13/16	2-1/2	2.00
WTC-6029		795 MCM	----	1-1/16	1-13/16	2-1/2	2.00
WTC-6221	3	550-556 MCM	----	1-1/4	1-3/4	2-3/8	0.75
WTC-6239		1250-1300 MCM	1113 MCM	1-1/8	2-1/16	2-1/2	0.75
WTC-6252		2500 MCM	----	2-9/16	2-3/16	4	0.75
WTC-6329	3-1/2	795 MCM	636 MCM	1-1/2	2	2-1/2	1.50
WTC-6337		1113 MCM	1033.5 MCM	1-1/2	2-3/8	2-3/4	2.00
WTC-6341		1431 MCM	1272 MCM	1-1/2	2-3/8	2-3/4	0.75
WTC-6433	4	954 MCM	715-795 MCM	1-1/4	2-3/4	2-3/4	1.25
WTC-6439		1250-1300 MCM	----	1-5/8	2-3/4	3	1.50
WTC-6446		1796 MCM	1590 MCM	2-1/4	2-3/4	3-3/4	3.05
WTC-6729	5	750-795 MCM	636-666 MCM	1-1/2	3	2-1/2	0.75
WTC-6746		----	1590 MCM	1-5/8	3-1/8	3-1/4	1.00
WTC-6752		2500 MCM	----	1-13/16	3-5/16	3-1/2	1.50
WTC-6952	6	2500 MCM	----	1-3/4	3-13/16	3-1/2	1.25