

ALUMINUM TEE CONNECTORS

TYPE ATRCT

Straight Bolted
Pipe Main to Cable Tap

Castings: 356-T6 Aluminum
Hardware: Aluminum Alloy

Aluminum alloy tee for aluminum pipe to cable connections. Clamping bolts have hex-stops for one-wrench installation. Contact sealant is recommended.

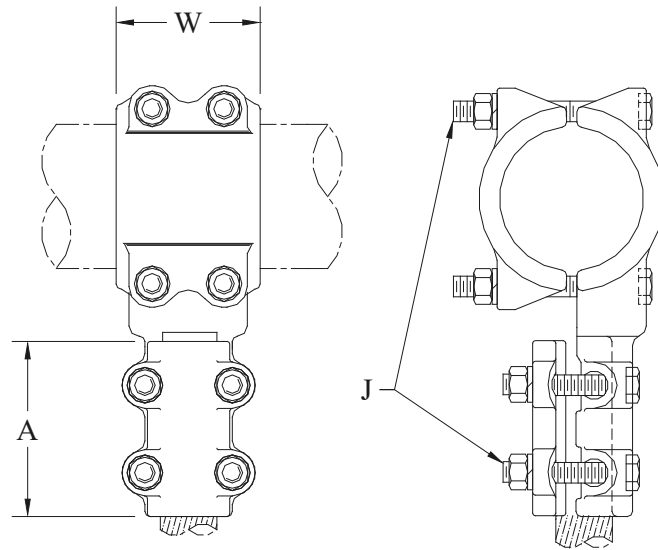

CATALOG NUMBER	CONDUCTOR RANGE		DIMENSIONS - INCHES			WEIGHT (POUNDS)	
	PIPE MAIN	CABLE TAP		A	W		J
		AAC	ACSR				
ATRCT-3013	3/4	#4-266 MCM	#4-4/0	3	2-3/8	1/2	2.05
ATRCT-3020		4/0-500 MCM	4/0-397 MCM	3-1/2	4	1/2	2.85
ATRCT-3024		350-650 MCM	336-556 MCM	4	2-3/8	1/2	2.55
ATRCT-3913	1	#4-266 MCM	#4-4/0	3	3	1/2	2.05
ATRCT-3920		4/0-500 MCM	4/0-397 MCM	3-1/2	3	1/2	2.55
ATRCT-3924		350-650 MCM	336-556 MCM	3	3	1/2	2.55
ATRCT-3934		550-1000 MCM	477-795 MCM	4	3	1/2	2.90
ATRCT-4920	1-1/4	4/0-500 MCM	4/0-397 MCM	3-1/2	2-3/4	1/2	2.35
ATRCT-4924		350-650 MCM	336-556 MCM	4	3	1/2	2.60
ATRCT-4934		550-1000 MCM	477-795 MCM	4	3	1/2	2.60
ATRCT-5313	1-1/2	#4-266 MCM	#4-4/0	3	3-1/8	1/2	2.85
ATRCT-5320		4/0-500 MCM	4/0-397 MCM	3-1/2	3	1/2	2.90
ATRCT-5324		350-650 MCM	336-556 MCM	4	3	1/2	3.15
ATRCT-5334		550-1000 MCM	477-795 MCM	4	3-1/8	1/2	3.40
ATRCT-5339		900-1300 MCM	715-1113 MCM	4-1/2	3-1/8	1/2	3.45
ATRCT-5813	2	#4-266 MCM	#4-4/0	3	3-1/2	1/2	3.10
ATRCT-5820		4/0-500 MCM	4/0-397 MCM	3-1/2	3-1/2	1/2	3.15
ATRCT-5824		350-650 MCM	336-556 MCM	4	3-1/2	1/2	3.65
ATRCT-5834		550-1000 MCM	477-795 MCM	4	3-1/2	1/2	3.35
ATRCT-5839		900-1300 MCM	715-1113 MCM	4-1/4	3-1/2	1/2	3.95
ATRCT-5843		1250-1590 MCM	1113-1431 MCM	4-1/2	3-1/2	1/2	4.70

Continued on next page

TYPE ATRCT - Continued

CATALOG NUMBER	CONDUCTOR RANGE		DIMENSIONS - INCHES			WEIGHT (POUNDS)	
	PIPE MAIN	CABLE TAP		A	W		J
		AAC	ACSR				
ATRCT-6013	2-1/2	#4-266 MCM	#4-4/0	3	3-1/2	1/2	3.35
ATRCT-6020		4/0-500 MCM	4/0-397 MCM	3-1/2	3-1/2	1/2	3.65
ATRCT-6024		350-650 MCM	336-556 MCM	4	3-1/2	1/2	3.90
ATRCT-6034		550-1000 MCM	477-795 MCM	4	3-1/2	1/2	3.90
ATRCT-6039		900-1300 MCM	715-1113 MCM	4-1/4	3-1/2	1/2	4.20
ATRCT-6043		1250-1590 MCM	1113-1431 MCM	4-1/2	3-1/2	1/2	4.70
ATRCT-6213	3	#4-266 MCM	#4-4/0	3	3-1/2	1/2	2.85
ATRCT-6220		4/0-500 MCM	4/0-397 MCM	3-1/2	3	1/2	3.05
ATRCT-6224		350-650 MCM	336-556 MCM	4	3-1/2	1/2	5.25
ATRCT-6234		550-1000 MCM	477-795 MCM	4	3-1/2	1/2	5.25
ATRCT-6239		900-1300 MCM	715-1113 MCM	4-1/4	3-1/2	1/2	5.30
ATRCT-6243		1250-1590 MCM	1113-1431 MCM	4-1/2	4	5/8	6.85
ATRCT-6320	3-1/2	4/0-500 MCM	4/0-397 MCM	3-1/2	3-1/4	1/2	4.45
ATRCT-6324		350-650 MCM	336-556 MCM	4	3-1/4	1/2	4.20
ATRCT-6334		550-1000 MCM	477-795 MCM	4	3-1/4	1/2	4.75
ATRCT-6339		900-1300 MCM	715-1113 MCM	4-1/4	3-1/4	1/2	5.05
ATRCT-6343		1250-1590 MCM	1113-1431 MCM	4-1/2	4-3/8	5/8	8.05
ATRCT-6420	4	4/0-500 MCM	4/0-397 MCM	3-1/2	3-1/4	1/2	5.50
ATRCT-6424		350-650 MCM	336-556 MCM	4	3-1/4	1/2	6.20
ATRCT-6434		550-1000 MCM	477-795 MCM	4	3-1/4	1/2	4.60
ATRCT-6439		900-1300 MCM	715-1113 MCM	4-1/4	3-1/4	1/2	6.30
ATRCT-6443		1250-1590 MCM	1113-1431 MCM	4-1/2	4-1/2	5/8	9.40
ATRCT-6449		1500-2000 MCM	1351-1780 MCM	4-1/2	4-1/2	1/2	7.75

*Contact factory for sizes not listed

TYPE AXTF

Bolted Expansion
Pipe Main to Pipe Tap

Castings: 356-T6 Aluminum
Laminated Straps: 1100-0 Aluminum
Hardware: Aluminum Alloy

Aluminum alloy expansion tee for aluminum pipe connections. Clamping bolts have hex-stops for one-wrench installation. Contact sealant is recommended. Add suffix (H) to catalog number for schedule 80 pipe.
Example: AXTF-6060H

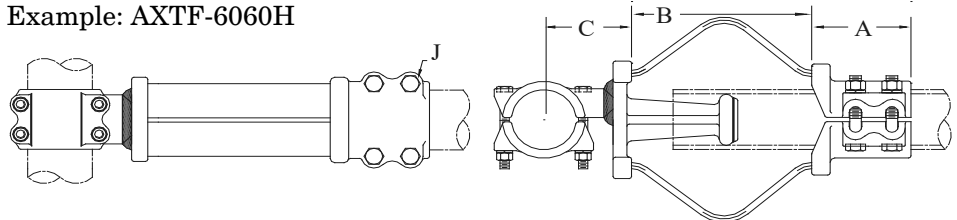

CATALOG NUMBER	CONDUCTOR SIZE (NPS)		DIMENSIONS - INCHES					WEIGHT (POUNDS)
	PIPE MAIN	PIPE TAP	A	B	C	W	J	
AXTF-5353	1-1/2	1-1/2	4-3/8	6-1/2	4-1/4	3-1/8	1/2	7.60
AXTF-5858	2	2	4-3/4	4	4-3/4	3-1/2	1/2	7.40
AXTF-6060	2-1/2	2-1/2	4-3/4	7-3/4	5-1/2	3-1/2	1/2	14.85
AXTF-6262	3	3	5-3/8	9-1/2	4-3/4	3-1/2	5/8	19.30
AXTF-6464	4	4	5-3/4	7	4-1/2	5-1/8	5/8	24.60

SEFCOR