

# ALUMINUM TEE CONNECTORS

## TYPE ATF

Straight Bolted  
Pipe Main to Flat Pad

Castings: 356-T6 Aluminum  
Hardware: Aluminum Alloy

Aluminum alloy tee for aluminum pipe to flat bar pads. NEMA hole drilling is standard. Clamping bolts have hex-stops for one-wrench installation. Contact sealant is recommended.

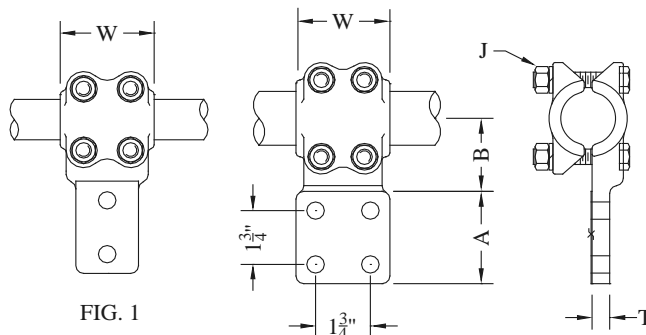

FIG. 1

FIG. 2

CATALOG NUMBER	FIG. NO.	CONDUCTOR SIZE		DIMENSIONS - INCHES					WEIGHT (POUNDS)
		PIPE MAIN	PAD WIDTH	A	B	W	T	J	
ATF-30-2B	1	3/4	2	3	1-7/8	2-3/8	3/8	1/2	1.40
ATF-30-4A	2		3	3	1-7/8	2-3/8	3/8	1/2	1.50
ATF-30-4B	2		4	4-1/4	1-7/8	2-3/8	3/8	1/2	2.00
ATF-39-2B	1	1	2	3	2	3	1/2	1/2	1.80
ATF-39-4A	2		3	3-3/8	1-3/4	3	1/2	1/2	1.85
ATF-39-4B	2		4	4	2-1/8	3	1/2	1/2	2.10
ATF-49-2B	1	1-1/4	2	3	2-3/8	3	9/16	1/2	2.10
ATF-49-4A	2		3	3	2-3/8	3	9/16	1/2	2.10
ATF-49-4B	2		4	4	2-1/2	3	3/8	1/2	2.10
ATF-53-2B	1	1-1/2	2	3	2-1/2	3-1/8	1/2	1/2	2.10
ATF-53-4A	2		3	3	2-1/2	3-1/8	1/2	1/2	2.35
ATF-53-4B	2		4	4	2-1/4	3	1/2	1/2	2.30
ATF-58-2B	1	2	2	3	2-3/4	3-1/2	5/8	1/2	2.35
ATF-58-4A	2		3	3	2-3/4	3-1/2	1/2	1/2	2.60
ATF-58-4B	2		4	4	2-3/4	3-1/2	7/16	1/2	3.00
ATF-60-2B	1	2-1/2	2	3	3-1/8	3-1/2	5/8	1/2	3.10
ATF-60-4A	2		3	3	3-1/8	3-1/2	5/8	1/2	3.10
ATF-60-4B	2		4	4	3-1/4	3-1/2	5/8	1/2	3.75
ATF-62-2B	1	3	2	3	3-3/8	3-1/2	1	1/2	2.95
ATF-62-4A	2		3	3	3-3/8	3-1/2	3/4	1/2	3.15
ATF-62-4B	2		4	4	3-1/4	3-1/2	3/4	1/2	4.20
ATF-63-2B	1	3-1/2	2	3	3-3/8	3-1/4	3/4	1/2	4.65
ATF-63-4A	2		3	3	3-3/8	3-1/4	3/4	1/2	4.65
ATF-63-4B	2		4	4	3-3/8	3-1/4	3/4	1/2	4.90
ATF-64-2B	1	4	2	3	3-3/4	3-1/4	3/4	1/2	3.95
ATF-64-4A	2		3	3	4-1/2	4-1/2	3/4	5/8	8.00
ATF-64-4B	2		4	4	4-1/2	4-1/2	3/4	5/8	8.00
ATF-67-4B	2	5	4	4	5-3/8	4-3/4	1	5/8	12.90
ATF-69-4B	2	6	4	4	5-1/2	7	1-1/8	5/8	18.30

\* Contact factory for other conductor combinations.

# SEFCOR