

ALUMINUM TERMINALS

TYPE WFTC

Weldment
Pipe to Flat

Castings: 356-T6 Aluminum
Options: See Page 211

Aluminum alloy weldment terminal for connecting aluminum pipe to flat pad. Center-formed tongues have NEMA drilling. Contact sealant is recommended for contact pad after welding.

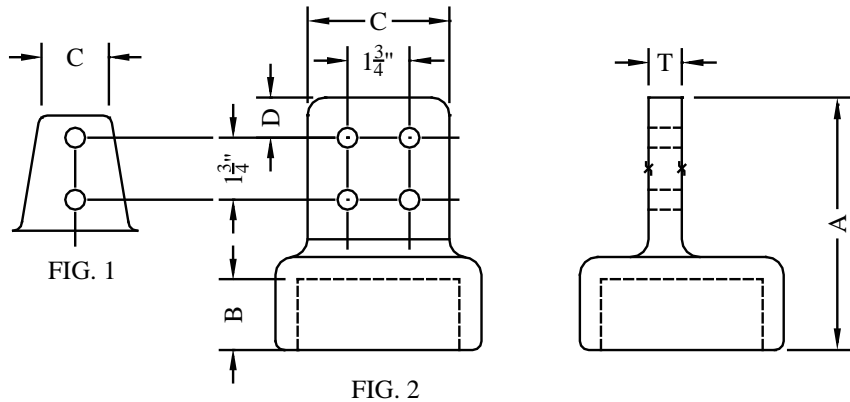

CATALOG NUMBER	FIG. NO.	PIPE SIZE (NPS)	DIMENSIONS-INCHES					WEIGHT (POUNDS)
			A	B	C	D	T	
WFTC-30-2B	1	3/4	4-5/8	15/16	2	5/8	3/8	0.40
WFTC-30-4A	2		4-5/8	15/16	3	5/8	3/8	0.50
WFTC-30-4B	2		5-5/8	15/16	4	1-1/8	3/8	0.60
WFTC-39-2B	1	1	4-5/8	15/16	2	5/8	3/8	0.40
WFTC-39-4A	2		4-5/8	15/16	3	5/8	3/8	0.50
WFTC-39-4B	2		5-5/8	15/16	4	1-1/8	3/8	0.60
WFTC-49-2B	1	1-1/4	4-3/4	1	2	5/8	3/8	0.80
WFTC-49-4A	2		4-3/4	1	3	5/8	3/8	0.90
WFTC-49-4B	2		5-3/4	1	4	1-1/8	3/8	1.00
WFTC-53-2B	1	1-1/2	5-1/8	1-3/8	2	5/8	1/2	1.00
WFTC-53-4A	2		5-1/8	1-3/8	3	5/8	1/2	1.00
WFTC-53-4B	2		6-1/8	1-3/8	4	1-1/8	1/2	1.25
WFTC-58-2B	1	2	5-1/4	1-1/2	2	5/8	1/2	1.25
WFTC-58-4A	2		5-1/4	1-1/2	3	5/8	1/2	1.50
WFTC-58-4B	2		6-1/4	1-1/2	4	1-1/8	7/16	1.75
WFTC-60-2B	1	2-1/2	5-7/16	1-1/2	2	5/8	1/2	1.50
WFTC-60-4A	2		5-5/16	1-1/2	3	5/8	1/2	1.70
WFTC-60-4B	2		6-1/4	1-1/2	4	1-1/8	1/2	2.10
WFTC-62-2B	1	3	5-3/4	1-3/4	2	5/8	5/8	2.40
WFTC-62-4A	2		5-3/4	1-3/4	3	5/8	5/8	2.60
WFTC-62-4B	2		6-3/4	1-3/4	4	1-1/8	5/8	2.90
WFTC-63-2B	1	3-1/2	5-3/4	1-7/8	2	5/8	3/4	2.75
WFTC-63-4A	2		5-3/4	1-7/8	3	5/8	3/4	3.00
WFTC-63-4B	2		6-7/8	1-7/8	4	1-1/8	3/4	3.50
WFTC-64-2B	1	4	5-7/8	2	2	5/8	3/4	3.00
WFTC-64-4A	2		5-7/8	2	3	5/8	3/4	3.30
WFTC-64-4B	2		6-13/16	2	4	1-1/8	15/16	3.80
WFTC-67-4A	2	5	7	2-7/8	3	5/8	1	6.20
WFTC-67-4B	2		8	2-7/8	4	1-1/8	1	6.60
WFTC-69-4B	2	6	8	2-3/4	4	1-1/8	1-1/8	8.50