

ALUMINUM MISCELLANEOUS

TYPE GSAL2N-4

Straight Bolted
Flat Pad to Stud

Castings: 356-T6 Aluminum

Aluminum grounding stud for grounding aluminum flat bar pads. NEMA drilling is standard. Contact sealant is recommended. A bronze version is also available. Contact factory for further information.

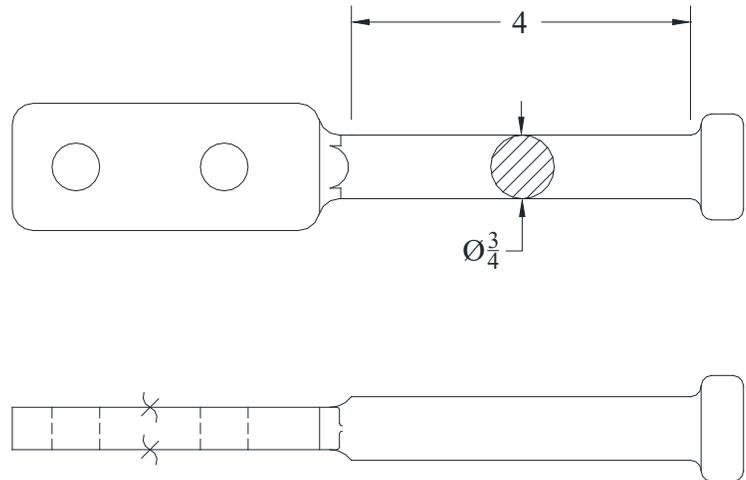

TYPE WEB

Internal - Welded
End Cap

Castings: 356-F Aluminum

Welded aluminum alloy internal end plug for pipe. Contact the factory for further information.

Add suffix "H" for schedule 80 pipe.

Example: WEB-58H

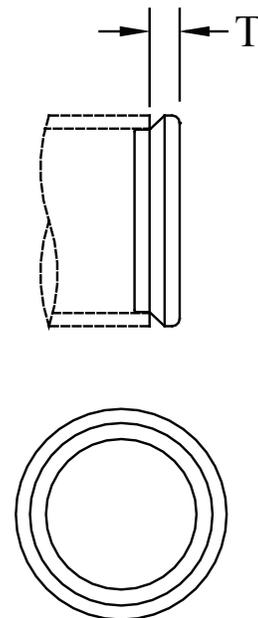

CATALOG NUMBER	CONDUCTOR SIZE (NPS)	THICKNESS (INCHES)	WEIGHT (POUNDS)
WEB-49	1-1/4	3/8	0.30
WEB-53	1-1/2	3/8	0.30
WEB-58	2	3/8	0.30
WEB-60	2-1/2	1/2	0.50
WEB-62	3	1/2	0.40
WEB-63	3-1/2	1/2	0.50
WEB-64	4	5/8	0.65
WEB-67	5	5/8	1.25
WEB-69	6	3/8	2.00
WEB-71	8	3/8	3.50