

# ALUMINUM MISCELLANEOUS

## TYPE PUAL

Parallel Connector  
Cable to Cable

Aluminum parallel connector for aluminum to aluminum conductor splice/  
tap connections.

Contact sealant is recommended.

Contact factory for further information.

Castings: 356-T6 Aluminum

Hardware: Stainless Steel

CATALOG NUMBER	RUN		TAP	
	AAC	ACSR	AAC	ACSR
PUAL-5050	2/0-4/0	1/0-3/0	2/0-4/0	1/0-3/0
PUAL-5555	1/0-400	#1-336	1/0-400	#1-336
PUAL-5951	250-650	4/0-556	#1-266	#2-4/0
PUAL-5959	250-650	4/0-556	250-650	4/0-556
PUAL-6155	500-800	397-636	1/0-400	#1-336
PUAL-6161	500-800	397-636	500-800	397-636
PUAL-6655	500-1033	397-954	1/0-400	#1-336
PUAL-6666	450-1033	397-954	450-1033	397-954

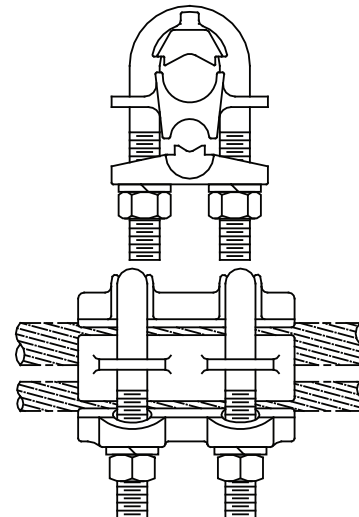

## TYPE ASPC

Straight Bolted  
Cable Spacer

Parallel cable spacer for maintaining cable clearance and  
preventing loose cable damage.

Contact factory for further information.

L=center line cable spacing.

Ex.: ASPC-20-8

For cable spacer with terminal add suffix - 2B,-4A, or -4B.

Ex: ASPC-20-8-4A.

Castings: 356-T6 Aluminum

Hardware: Aluminum Alloy

CATALOG NUMBER	CONDUCTOR RANGE	
	AAC	ACSR
ASPC-20-(L)	336-600 MCM	336-477 MCM
ASPC-22-(L)	556.5 MCM	477 MCM
ASPC-24-(L)	636-750 MCM	556.5 MCM
ASPC-29-(L)	750-795 MCM	636-666 MCM
ASPC-32-(L)	795-900 MCM	666-715 MCM
ASPC-34-(L)	954-1000 MCM	795 MCM
ASPC-35-(L)	954-1033 MCM	900-954 MCM
ASPC-36-(L)	954-1113 MCM	900-1033 MCM
ASPC-38-(L)	1113-1272 MCM	1033-1192.5 MCM
ASPC-39-(L)	1113-1272 MCM	954-1192.5 MCM
ASPC-41-(L)	1272-1431 MCM	1192-1272 MCM
ASPC-43-(L)	1431-1590 MCM	1272-1431 MCM
ASPC-46-(L)	1590-1750 MCM	1510-1590 MCM
ASPC-49-(L)	2000 MCM	1780 MCM
ASPC-51-(L)	2250-2500 MCM	2156-2312 MCM

