

SEFCOR, INC.

Power Connector Specialist

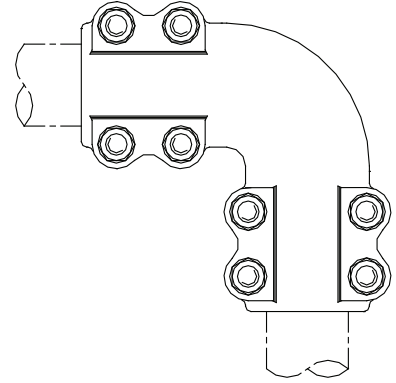

Product Catalog

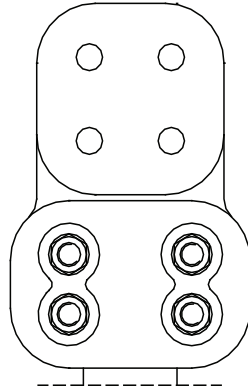
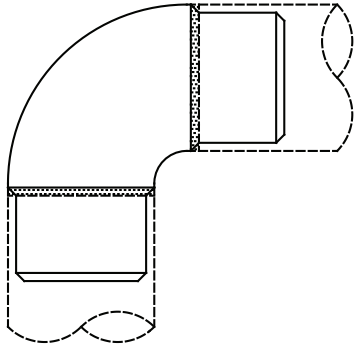
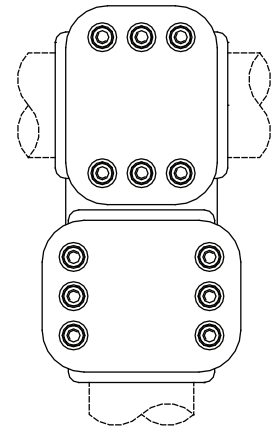
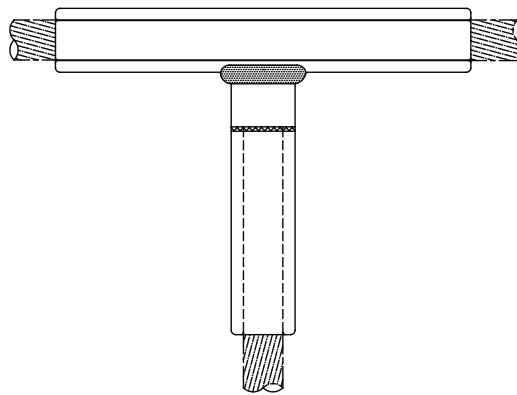
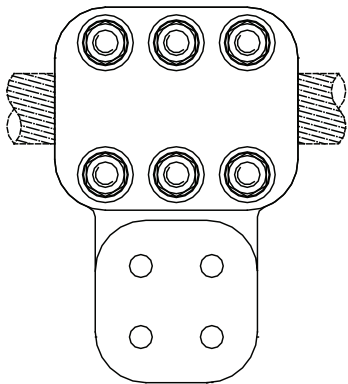
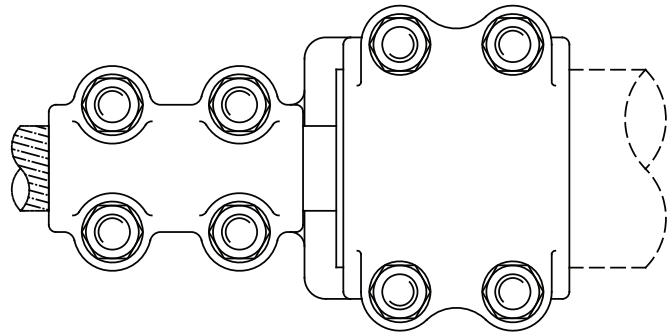
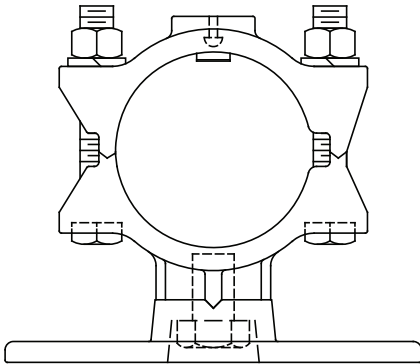

SEFCOR TERMS AND CONDITIONS OF SALE JANUARY 1, 2024

1. **ACCEPTANCE OF ORDERS**
All orders are subject to acceptance by seller at General Office.
2. **PRICE POLICY**
All prices are subject to change without notice.
3. **TERMS**
Net thirty (30) days from date of invoice. No cash discount. Incremental billings will be made.
4. **TAXES**
All prices, unless otherwise indicated, are subject to the addition of any and all excise, sales, and other taxes which may be applicable.
5. **PACKAGING**
All prices include domestic packaging. Export or special packaging is subject to extra charge for purchaser's account.
6. **TRANSPORTATION**
All shipments are F.O.B. SEFCOR factory. The most economical transportation will be allowed to domestic freight stations, excluding Alaska and Hawaii or orders of \$750.00 or more to one destination at one time. When purchaser specifies that shipments are made by any other than normal manner, additional expense is to be borne by the purchaser.
7. **CANCELLATIONS OR CHANGES**
All orders are subject to acceptance by Seller at General Office. Orders may not be changed or cancelled in whole or in part without seller's prior written consent. No order accepted by SEFCOR may be altered or modified by purchaser unless agreed to in writing, signed by an authorized official of SEFCOR and no such order may be cancelled or terminated except upon payment of SEFCOR's loss, damage or expense arising from such cancellation or termination up to and including obligation charges from the suppliers of SEFCOR.
8. **RETURN OF GOODS**
Permission in writing must be obtained from SEFCOR prior to returning goods for credit or replacement. On those standard catalog items accepted for return, not involving a SEFCOR error, which are received and found to be of current design and in reasonable condition, credit will be issued at the original invoice price less return charges plus freight. Non-stock items and customer special orders will generally not be accepted for return and are subject to special terms and conditions for return and restocking which will be agreed to in writing by both Seller and Purchaser prior to accepting products at the loading docks of SEFCOR, Inc., Griffin, GA.
9. **CLAIMS**
Claims for errors, shortages or defective goods must be made within ten (10) days after receipt of material. Where shipments are made F.O.B. factory, carriers are responsible for goods lost or damaged in transit.
10. **SHIPPING SCHEDULES**
Estimated shipping schedules constitute the current cycle of components required for manufacture. Seller shall not be liable for failure or delay in manufacture, shipment or delivery due to causes beyond its reasonable control including, but not by way of limitation, acts of God; the purchaser; civil or military authorities; provision of law or governmental regulations; accident; explosion; fire; flood; windstorm or other casualty; strikes; lockouts, or other labor difficulties; riot; war; civil commotion; delays in transportation; car shortage; inability to obtain necessary labor, materials or manufacturing.
11. **WARRANTIES, LIABILITY AND DAMAGES**
SEFCOR warrants a normal level of commercial quality of material and workmanship in its products conforming to its written specifications and drawings. All other warranties are excluded, whether express or implied by operation of law or otherwise, including all implied warranties or merchantability of fitness. Seller shall not be liable to purchaser or any third party for consequential damages directly or indirectly arising or resulting from the breach of any of the terms hereof or from the sale or use of the products sold. Seller's liability, either for breach of warranty or for negligence, is limited at the option of the seller to either the replacement of products not complying with the terms hereof, or to the repair of such products, or to the refund or crediting to purchaser of the price of such products.
12. **TOOLING**
Interest in any patterns, tools, dies, jigs, fixtures and items of like nature required for manufacture remain the sole property of SEFCOR.
13. **WAIVER**
Waiver of any breach of this contract shall not be construed as a waiver of any other breach.

NOTE: For Special Engineering, applications or unusual trucking requirements, please call the factory.
Shipping weights are approximate and not Guaranteed.

SEFCOR, INC.

A tradition of excellence!

Since 1971, **SEFCOR** has built a reputation as a supplier of quality power connectors with short lead times at competitive prices. With sales offices located coast-to-coast, **SEFCOR** has quickly become one of the nation's leading suppliers to the Electric Power Industry.

SEFCOR connectors are designed in accordance with the latest industry NEMA and ANSI standards. Our patterns and molds are made under our control in accordance to our exacting standards, and are carefully tested, checked and inspected rigorously to insure conformance before production begins.

Fittings are produced by independent foundries highly skilled and specialized in the manufacture of aluminum and bronze castings. Casting inspection, machining, welding, and assembly are completed in our Griffin, Georgia facility. The connectors are cleaned, brightened and prepared for shipment. All high-voltage fittings are buffed to a fine finish to insure corona-free operation. Final inspection is performed on 100% of all items prior to being released for shipment.

SEFCOR designs solutions!

With over 25,000 standard and special designs available, **SEFCOR** already has a connector for most applications. However, when unique situations call for specially designed items we stand ready to serve our customers.

SEFCOR has been designing solutions for electric utilities, both large and small, for over 30 years. Our customer designed connectors are available in large and small quantities to support both transmission and distribution systems. Best of all, **SEFCOR** design solutions are available regardless of the size of your need, from one to one thousand or more, with competitive pricing and reliable on-time deliveries.

SEFCOR fabricates!

SEFCOR offers specialized on-site welding and fabrication services for substation construction. "A" Frames and other components can be prefabricated to your specifications to reduce installation time, labor and save money.

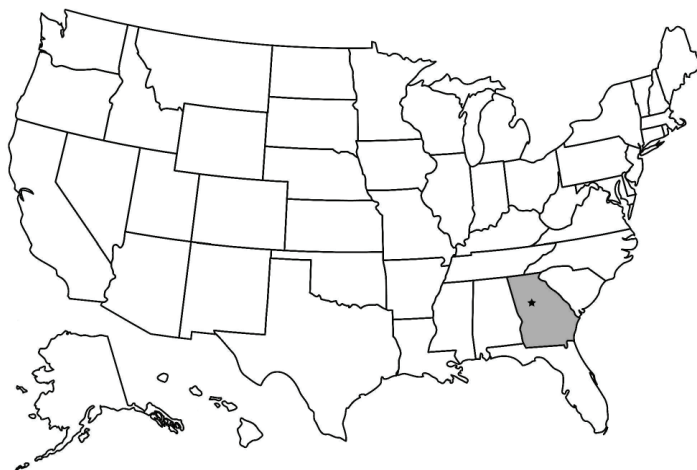

National availability!

SEFCOR is represented nationally by a network of local representatives. Our Users List includes the major utilities throughout the United States. Our International Customer Base increases annually.

SEFCOR

SEFCOR INDEX BY TYPE

ALUMINUM BUS SUPPORTS	1	WVTSI-CS2	43	ATTHV	80
ACSTI	2	WXCCI	44	AVTHV-15	81
ACTI	3	WXCTO-CS1	45	ATTHV-15	81
ASCRI	4	WXCTO-CS2	46	WFTT15-HV	82
ASTI	5	ALUMINUM TEE CONNECTORS	47	WFVT15-HV	82
ASTI-R	6	ACF	49	WFTT-HV	83
ASWH	7	ACRCT	50	WTC	84
AVCA	8	ATCXT	51	WTF-HV	85
AVCA2	9	ATF	52	WTFR-HV	85
AVTI	10	ATRCT	53	WTTC3	87
AXCTO	11	ATT	55	WTTC	86
WCTI	12	ATTT	55	ALUMINUM TERMINALS	88
WRTI	13	ATT15	57	AFNC	90
WTSI	14	AVT15	58	AFNC2	91
WVTI	15	AXTF	59	AFNC3	92
WXCTO	16	WFTT	60	AFNC90	93
BRONZE BUS SUPPORTS	17	WFTT15	62	AFNT	94
ASTI-BR	18	WFVT15	64	AFNT90	96
CCTI	19	WTC	65	AFNTC	98
CJ	20	WTF	66	AFXT	99
CN	21	WTFR	66	AFXT-V	100
CXTI	22	WYT	59	AFXT0	101
SCRI	23	WYTI	59	ASFFT	102
SCRI2	24	BRONZE TEE CONNECTORS	47	ASFFT90	103
SCTI	25	ATT15-BR	67	ASXR	104
SVTI	26	AVT15-BR	68	ASXR2	104
EHV BUS SUPPORTS	27	FNXR	248	FNXR-AL	104
ARTIHV	28	TCRCT	69	WFC	105
ASCA3	29	TDRCT	75	WFC2	107
ASCAHV	30	TFC	70	WFC3	109
ASTIHV	31	TFT	71	WFT	110
ASTIHV-R	32	TTHT	74	WFTC	111
ASWH-EHV	33	TTRCT	73	WFTI	112
AVCAD	34	TTRDT	75	WFTIC	113
AVCA-HV	35	TTT	74	WFTIR	114
AVCHV	36	TXR	253	WFTIW	114
WCTI-EHV	37	EHV TEE CONNECTORS	47	WFXIW	114
WRTIHV	38	ACFHV	76	WFTO	115
WRTIHV2	38	ACF2-HV	76	WFTOC	116
WSTIHV	39	ACFHV2	77	WFXT	117
WVTI-CS1	40	ACRCT-HV	78	WFXTC	118
WVTI-CS2	41	ATFHV	79	WFXTC-V	119
WVTSI-CS1	42	ATFRHV	79	WSFFT	120

SEFCOR INDEX BY TYPE

WSFFT90	121	ACCC	154	WFTIR	114
BRONZE TERMINALS	122	ACTC	155	CABLE SPACERS	188
FNCT	124	ALB45	156	ASBC3	193
FNCT2	125	ALB90	157	ASBC4	193
FNCT3	126	ALB-V	158	ASPC	189
FNCT4	127	ASCT	159	ASPC	191
FNCT90	128	AXCF	160	ASPC-4B	191
FNTT	129	WLBI45	161	ASPC-BR	190
FNTT90	130	WLBI90	161	ASPCHV	192
FNTTC	131	WLBUA	162	CSPS	190
FNXT	132	WSC	163	ALUMINUM STUD CONNECTORS	195
SFFT	133	WSCL	163	ASCC	196
SFFT90	134	WSCR	164	ASCC90	196
SXR	135	WXCF	165	ASFF	197
SXR2	135	BRONZE COUPLERS	153	ASFFT	204
FNXR	135	ACCC-BR	166	ASFFT90	204
UK	136	CCT	167	ASTR	201
UKG	136	CXT	168	ASTT	199
UKL	136	ETRCT	169	ASTT90	199
UMX	137	LB45	170	ASXR	198
FNSS	137	LB90	170	ASXR2	198
GLT-12	137	EHV COUPLERS	153	ASXTR	203
UN	138	ACTCHV	171	WSFFT	205
UNN	138	ALBHV-V	172	WSFFT90	205
EHV TERMINALS	139	ASCTHV	173	WSTR	202
AFN3HV	141	WBCHV	174	WSXTR	204
ADPHV-4B	141	WETC2	175	BRONZE STUD CONNECTORS	206
AFBH	142	WFTD	176	SATA	208
AFBV	142	WLBI-HV	177	SAX	210
AFNCHV	143	WLBUA	178	SAX2	211
AFNTC-HV	144	WSC	179	SCC	212
WFCHV	145	WSR	179	SCC90	212
WFC2HV	146	WSTC3	180	SCC2	213
WFC3HV	147	WXCCF	181	SFFT	214
WFCCH	148	WXCF-CS	182	SFFT90	216
WFCCV	148	END CAPS AND CORONA BELLS	183	SHN	215
WFRTC-V	149	ABIR	185	SNFT	218
WFXTC-V-CS	149	DP-AL	184	SNFT90	220
WFTCHV	150	DP-BR	186	SNFV	221
WFTD	150	DPS-AL	184	SNX	217
WFTICHV	151	DPS-BR	186	STT	222
WHV-FXT	152	WEB	185	STT90	222
ALUMINUM COUPLERS	153	WEPC	187	SXR	224

SEFCOR INDEX BY TYPE

SXR2	224	CFX	246	GTC2	266
SXT	225	CFX90	246	GU1	267
SXT90	225	FNXR	248	GUR	268
EHV STUD CONNECTORS	227	GCK	247	OCS	271
AS3N90	231	GFCS	247	OF	269
ASN3HV	230	GLT-12	247	PL	269
ASNF2HV	229	HLS	249	UN	270
ASNFHV	228	HLSC	249	UNN	270
ASNFHV90	228	OGC	250	XBG	271
ASNFHV-BR	228	OGP	250	XB2N	272
WSXHV	233	PA	251	XB4N	272
WSXTRHV	232	PAU	251	COMPRESSION CONNECTORS	273
ALUMINUM MISCELLANEOUS	234	PDC	252	AL	274
AA-1156	235	PGC2	252	AL (For CD Die)	279
AA-1467	235	PL	251	AL-EHV	275
AFX	236	PT	252	AL2	290
AFX90	236	PU	250	ARS	290
AHLS	237	SXR	248	AS	290
AHLSC	237	SXR2	248	ATCC	290
AHLS-UABC	238	TASP	253	ATCC-EHV	290
AHLSW	238	TXR	253	ATCF	281
AHLSW-UABC	238	UMX	254	ATCF (For CD Die)	284
APGC	239	XB2N	254	ATCF-EHV	282
ASIW	240	XB4N	254	CL	286
ASIWP	240	EHV MISCELLANEOUS	234	CS	290
ASUA	241	ABGSH	255	CTCC	290
ASUA2	241	WGSTH	255	CTCF	288
ATP	239	WGSTE	255	QCT-HV	290
ATS	242	EHV HARDWARE SHIELDS	256	STRAIN HARDWARE	291
BSA	235	AA-1094	257	AQD	292
GSAL2N-4	242	HS-6B	257	ASDE	293
HA3	235	AA-1207	258	ANCHOR SHACKLE	299
HA5	235	AA-1520	258	BALL Y-CLEVIS	299
PUAL	243	GROUND CONNECTORS	259	BCS/BCSS	295
WRLA	244	1-OC	260	CLEVIS-CLEVIS	297
WTS	243	2-OC	262	CLEVIS-EYE	296
WVB	244	GBR	263	CHAIN LINK	297
BRONZE MISCELLANEOUS	234	GCK	263	FQD	294
BCGS	245	GF	264	SOCKET-EYE	296
BCS	245	GF2	264	SOCKET CLEVIS	298
BCSS	245	GLT-12	265	Y-CLEVIS CLEVIS	298
BSA	245	GTT2	265	YOKE PLATES	300
BTS	245	GTC	266	ES EXTENSION STRAP	301

SEFCOR ALPHA NUMERIC INDEX

1-OC	260	AHLSW-UABC	238	ASTI-BR	18	AXCF	160
2-OC	262	AL	274	ASTIHV	31	AXCTO	11
AA-1094	257	AL2	290	ASTIHV-R	32	AXTF	59
AA-1156	235	ALB45	156	ASTI-R	6	BALL Y-CLEVIS	299
AA-1207	258	ALB90	157	ASTR	201	BCGS	245
AA-1467	235	ALBHV-V	172	ASTT	199	BCS	245, 295
AA-1520	258	ALB-V	158	ASTT90	199	BCSS	245, 295
ABGSH	255	AL-EHV	275	ASUA	241	BSA	235, 245
ABIR	185	ANCHOR SHACKLE	299	ASUA2	241	BTS	245
ACCC	154	APGC	239	ASWH	7	CCT	167
ACCC-BR	166	AQD	292	ASWH-EHV	33	CCTI	19
ACF	49	ARS	290	ASXR (TERMINAL)	104	CFX	246
ACF2-HV	76	ARTIHV	28	ASXR (STUD)	198	CFX90	246
ACFHV	76	AS	290	ASXR2 (TERMINAL)	104	CHAIN LINK	297
ACFHV2	77	AS3N90	231	ASXR2 (STUD)	198	CJ	20
ACRCT	50	ASBC3	193	ASXTR	203	CL	286
ACRCT-HV	78	ASBC4	193	ATCC	290	CLEVIS-CLEVIS	297
ACSTI	2	ASCA3	29	ATCC-EHV	290	CLEVIS-EYE	296
ACTC	155	ASCAHV	30	ATCF	281	CN	21
ACTCHV	171	ASCC	196	ATCF (For CD Die)	284	CS	290
ACTI	3	ASCC90	196	ATCF-EHV	282	CSPS	190
ADPHV-4B	141	ASCRI	4	ATCXT	51	CTCC	290
AFBH	142	ASCT	159	ATF	52	CTCF	288
AFBV	142	ASCTHV	173	ATFHV	79	CXT	168
AFN3HV	141	ASDE	293	ATFRHV	79	CXTI	22
AFNC	90	ASFF	197	ATP	239	DP-AL	184
AFNC2	91	ASFFT (TERMINAL)	102	ATRCT	53	DP-BR	186
AFNC3	92	ASFFT (STUD)	204	ATS	242	DPS-AL	184
AFNC90	93	ASFFT90 (TERMINAL)	103	ATT	55	DPS-BR	186
AFNCHV	143	ASFFT90 (STUD)	204	ATT15	57	ES EXTENSION STRAP	301
AFNT	94	ASIW	240	ATT15-BR	67	ETRCT	169
AFNT90	96	ASIWP	240	ATTHV	80	FNCT	124
AFNTC	98	ASN3HV	230	ATTHV-15	81	FNCT2	125
AFNTC-HV	144	ASNF2HV	229	ATTT	55	FNCT3	126
AFX	236	ASNFHV	228	AVCA	8	FNCT4	127
AFX90	236	ASNFHV90	228	AVCA2	9	FNCT90	128
AFXT	99	ASNFHV-BR	228	AVCAD	34	FNSS	137
AFXTO	101	ASPC	189	AVCA-HV	35	FNTT	129
AFXT-V	100	ASPC	191	AVCHV	36	FNTT90	130
AHLS	237	ASPC-4B	191	AVT15	58	FNTTC	131
AHLS-C	237	ASPC-BR	190	AVT15-BR	68	FNXR	135, 248
AHLS-UABC	238	ASPCHV	192	AVTHV-15	81	FNXR-AL	104
AHLSW	238	ASTI	5	AVTI	10	FNXT	132

SEFCOR ALPHA NUMERIC INDEX

FQD	294	SFFT (STUD)	214	WFC2HV	146	WSCL	163
GBR	263	SFFT90 (TERMIAL)	134	WFC3	109	WSCR	164
GCK	247, 263	SFFT90 (STUD)	216	WFC3HV	147	WSFFT (TERMINAL)	120
GF	264	SHN	215	WFCCH	148	WSFFT (STUD)	205
GF2	264	SNFT	218	WFCCV	148	WSFFT90 (TERMINAL)	121
GFCS	247	SNFT90	220	WFCHV	145	WSFFT90 (STUD)	205
GLT-12	137, 247, 265	SNFV	221	WFRTC-V	149	WSR	179
GSAL2N-4	242	SNX	217	WFT	110	WSTC3	180
GTC	266	SOCKET CLEVIS	298	WFTC	111	WSTIHV	39
GTC2	266	SOCKET-EYE	296	WFTCHV	150	WSTR	202
GTT2	265	STT	222	WFTD	150	WSXHV	233
GU1	267	STT90	222	WFTD	176	WSXTR	204
GUR	268	SVTI	26	WFTI	112	WSXTRHV	232
HA3	235	SXR (TERMINAL)	135, 248	WFTIC	113	WTC	65, 84
HA5	235	SXR (STUD)	224	WFTICHV	151	WTF	66
HLS	249	SXR2 (TERMINAL)	135, 248	WFTIR	114	WTF-HV	85
HLSC	249	SXR2 (STUD)	224	WFTIR	114	WTFR	66
HS-6B	257	SXT	225	WFTIW	114	WTFR-HV	85
LB45	170	SXT90	225	WFTO	115	WTS	243
LB90	170	TASP	253	WFTOC	116	WTSI	14
OCS	271	TCRCT	69	WFTT	60	WTTC3	87
OF	269	TDRCT	75	WFTT15	62	WTTC	86
OGC	250	TFC	70	WFTT15-HV	82	WVB	244
OGP	250	TFT	71	WFTT-HV	83	WVTI	15
PA	251	TTHT	74	WFVT15	64	WVTI-CS1	40
PAU	251	TTRCT	73	WFVT15-HV	82	WVTI-CS2	41
PDC	252	TTRDT	75	WFXIW	114	WVTSI-CS1	42
PGC2	252	TTT	74	WFXT	117	WVTSI-CS2	43
PL	251, 269	TXR	253	WFXTC	118	WXCCF	181
PT	252	UK	136	WFXTC-V	119	WXCCI	44
PU	250	UKG	136	WFXTC-V-CS	149	WXCF	165
PUAL	243	UKL	136	WGSTE	255	WXCF-CS	182
QCT-HV	290	UMX	137, 254	WGSTH	255	WXCTO	16
SATA	208	UN	138, 270	WHV-FXT	152	WXCTO-CS1	45
SAX	210	UNN	138, 270	WLBI45	161	WXCTO-CS2	46
SAX2	211	WBCHV	174	WLBI90	161	WYT	59
SCC	212	WCTI	12	WLBI-HV	177	WYTI	59
SCC2	213	WCTI-EHV	37	WLBUA	162, 178	XB2N	254, 272
SCC90	212	WEB	185	WRLA	244	XB4N	254, 272
SCRI	23	WEPC	187	WRTI	13	XB4N	272
SCRI2	24	WETC2	175	WRTIHV	38	XBG	271
SCTI	25	WFC	105	WRTIHV2	38	Y-CLEVIS CLEVIS	298
SFFT (TERMINAL)	133	WFC2	107	WSC	163, 179	YOKE PLATES	300

STANDARDS

STANDARD PAD SIZES*	
REF	DIM
2A	1-1/2" X 3"
2B	2" X 3"
4A	3" X 3"
4B	4" X 4"
6A	5" X 4"
6B	6" X 4"

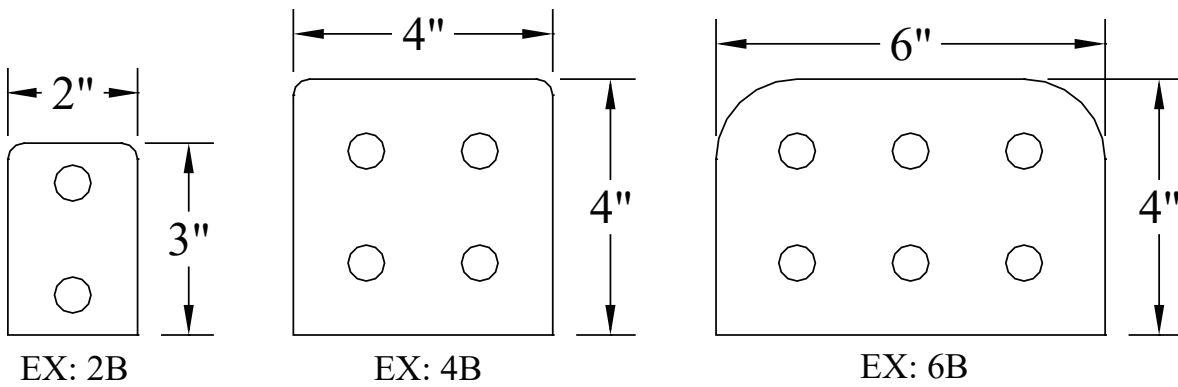

STANDARD PIPE SIZES			
REF	NPS	REF	NPS
11	1/4"	62	3"
16	3/8"	63	3-1/2"
21	1/2"	64	4"
30	3/4"	65	4-1/2"
39	1"	67	5"
49	1-1/4"	69	6"
53	1-1/2"	70	8" O.D.
58	2"	71	8"
60	2-1/2"	72	10"

STANDARD STUD SIZES**			
REF	DIM	REF	DIM
10	1/2"	57	2-1/4"
14	5/8"	59	2-1/2"
18	3/4"	61	3"
21	7/8"	62	3-1/2"
27	1"	63	4"
33	1-1/8"	64	4-1/2"
36	1-1/4"	65	5"
44	1-1/2"	66	5-1/2"
50	1-3/4"	68	6"
54	2"		

*NON-STANDARD OPTIONS AVAILABLE - MEASUREMENTS SHOWN BASED ON NEMA STANDARDS.

**METRIC SMOOTH, METRIC THREADED, AND OTHER SIZES ARE AVAILABLE - CONTACT FACTORY

STANDARDS

OPTIONS	
A()	FACTORY SET ANGLE (eg. A45 = 45° angle)
AG	SILVER-PLATED ENTIRE ASSEMBLY
BP	BLANK PAD-NO HOLES IN CONTACT PAD
CCN	SUPPLIED WITH CONTACT NUTS
CNS	SUPPLIED WITH CAP NUTS
E	EXTENSION PAD
EHV	EXTRA HIGH VOLTAGE APPLICATION
ETP	ELECTRO TIN-PLATED
FF	FINISHED BOTH SIDES OF CONTACT PAD
GS	GALVANIZED STEEL HARDWARE
GR5	GRADE 5 GALV STEEL BOLT- GALV HARDWARE
H	HEAVY (EXTRA THICKNESS CONTACT PAD)
H	INTERNAL FIT WHEN SCH80 PIPE USED
HS	SUPPLIED WITH HARDWARE SHIELD
M72	STAINLESS STEEL HARDWARE WITH BRONZE NUT
MB	WITH TONGUE MOUNTING HARDWARE
P	PIN INSULATOR MOUNTING HARDWARE
RFO	RIGID FIT ONLY, BUS SUPPORTS
S	SHORT BARREL FOR COMPRESSION
SE	STATIC ELIMINATOR SPRING
SFO	SLIP FIT ONLY, BUS SUPPORT
SND	TIN-PLATED ENTIRE ASSEMBLY
SP	SPECIAL REQUIREMENT, REFER TO FACTORY
SS	STAINLESS STEEL HARDWARE
TO	SMOOTH STUD BORE - NO THREADS
T()	SPECIAL STUD THREADS (eg. T10 = 10TPI)

*NON-STANDARD OPTIONS AVAILABLE - MEASUREMENTS SHOWN BASED ON NEMA STANDARDS.

**METRIC SMOOTH, METRIC THREADED, AND OTHER SIZES ARE AVAILABLE - CONTACT FACTORY

ALUMINUM BUS SUPPORTS



ACSTI



ACTI



ASCRI



ASTI

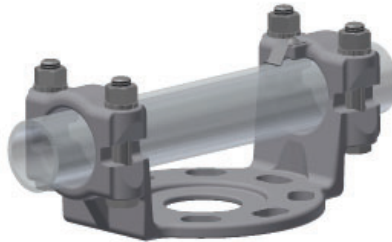

ASTI-R



ASWH



AVCA

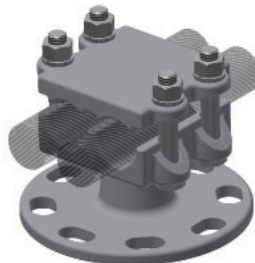

AVCA2



AVTI



AXCTO

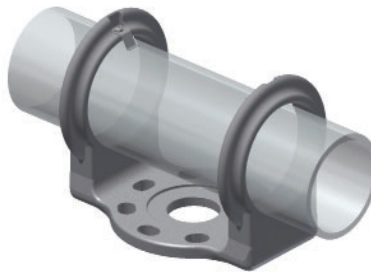

WCTI

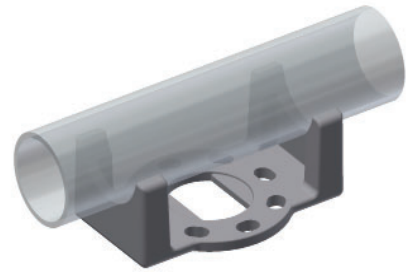

WRTI

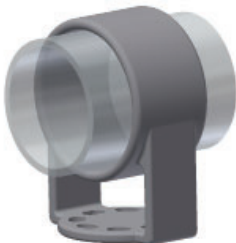

WTSI

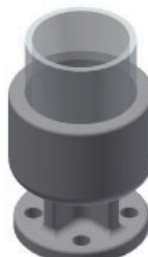

WVTI



WXCTO

ALUMINUM BUS SUPPORTS

TYPE ACSTI

Horizontal Bolted (Coupler)

Pipe to Insulator

Aluminum alloy bus support sliding coupler for aluminum pipe.
Clamping bolts have hex-stops for one-wrench installation.

Hardware supplied for CAP mounting.
For PIN mounting, add suffix (P) to catalog number.
Example: ACSTI-60-5P

Casting Alloy: 356-T6 Aluminum
Clamping Hardware: Aluminum Alloy
Mounting Hardware: Galvanized Steel

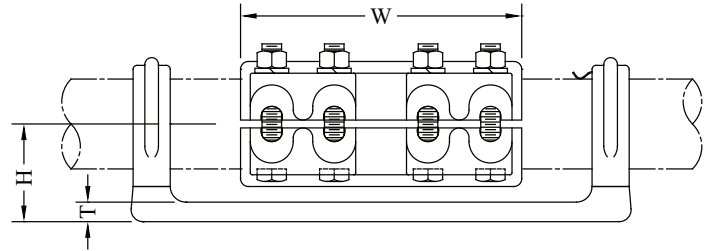
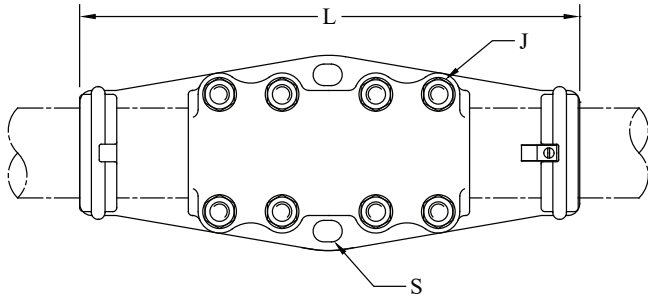

CATALOG NUMBER	PIPE SIZE (NPS)	BOLT CIRCLE	DIMENSIONS - INCHES						WEIGHT (POUNDS)
			H	L	W	S	J	T	
ACSTI-58-3	2	3	2-3/4	12-3/4	7-1/2	9/16 x 3/4	1/2	5/8	9.60
ACSTI-58-5		5	2-3/4	16	9-1/4	11/16 x 1	1/2	5/8	10.40
ACSTI-60-3	2-1/2	3	3-1/8	17-3/8	9	9/16 x 13/16	5/8	1/2	13.30
ACSTI-60-5		5	3-1/8	16	9	11/16 x 1-1/16	5/8	5/8	14.10
ACSTI-62-3	3	3	3-5/8	17-3/8	10-1/8	9/16 x 13/16	5/8	1/2	15.70
ACSTI-62-5		5	3-5/8	15-7/8	10-1/8	11/16 x 1-1/16	5/8	5/8	17.30
ACSTI-63-3	3-1/2	3	4	16	11	9/16 x 13/16	5/8	5/8	16.50
ACSTI-63-5		5	4	16	11	11/16 x 1-1/16	5/8	5/8	16.90
ACSTI-64-3	4	3	4-1/2	17-1/2	12	9/16 x 13/16	5/8	1/2	23.70
ACSTI-64-5		5	4-1/2	16	12	11/16 x 1-1/16	5/8	1/2	24.50
ACSTI-67-3	5	3	5	19-5/8	13-1/4	9/16 x 13/16	5/8	5/8	26.30
ACSTI-67-5		5	5	19-5/8	13-1/2	11/16 x 1	5/8	5/8	26.30
ACSTI-69-3	6	3	5-1/2	20-1/4	12-3/4	9/16 x 13/16	5/8	5/8	25.50
ACSTI-69-5		5	5-1/2	20-1/4	12-3/4	11/16 x 1-1/16	5/8	5/8	25.50

ALUMINUM BUS SUPPORTS

TYPE ACTI

Horizontal Bolted (Coupler)
Pipe to Insulator

Aluminum alloy rigid bus support for aluminum pipe.
Clamping bolts have hex stops for one wrench installation.

Hardware supplied for CAP mounting.
For PIN mounting, add suffix (P) to catalog number.
Example: ACTI-60-3P

Casting Alloy: 356-T6 Aluminum
Clamping Hardware: Aluminum Alloy
Mounting Hardware: Galvanized Steel

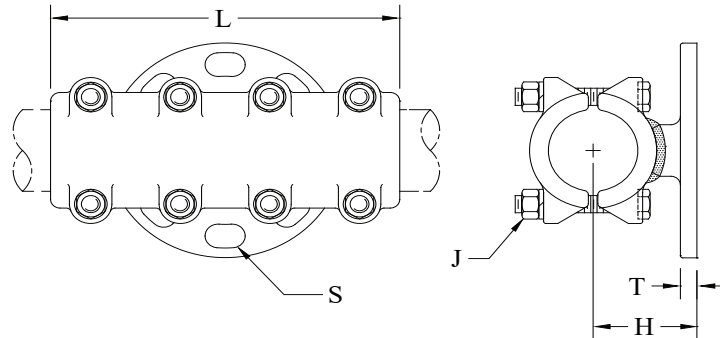

CATALOG NUMBER	PIPE SIZE (NPS)	BOLT CIRCLE	DIMENSIONS - INCHES					WEIGHT (POUNDS)
			H	L	J	S	T	
ACTI-30-3	3/4	3	2-1/16	6-1/4	1/2	9/16 x 13/16	3/8	3.50
ACTI-30-5		5	2-1/16	6-1/4	1/2	11/16 x 1	3/8	4.10
ACTI-39-3	1	3	2-1/4	6-1/4	1/2	9/16 x 13/16	3/8	3.75
ACTI-39-5		5	2-1/4	6-1/4	1/2	11/16 x 1	3/8	4.35
ACTI-49-3	1-1/4	3	2-1/4	5-3/4	1/2	9/16 x 13/16	1/4	2.60
ACTI-49-5		5	2-3/8	5-3/4	1/2	11/16 x 1	3/8	3.30
ACTI-53-3	1-1/2	3	2-1/2	6-1/4	1/2	9/16 x 13/16	5/16	4.80
ACTI-53-5		5	2-1/2	6-1/4	1/2	11/16 x 1-1/16	5/16	5.45
ACTI-58-3	2	3	2-3/4	9-1/4	1/2	9/16 x 7/8	3/8	5.10
ACTI-58-5		5	2-3/4	9-1/4	1/2	11/16 x 1	7/16	5.70
ACTI-60-3	2-1/2	3	3-1/8	8-1/4	1/2	9/16 x 13/16	3/8	5.90
ACTI-60-5		5	3-1/8	8-1/4	1/2	11/16 x 1	3/8	6.45
ACTI-62-3	3	3	3-5/8	10-1/8	5/8	9/16 x 13/16	7/16	11.35
ACTI-62-5		5	3-5/8	10-1/8	5/8	11/16 x 1-1/16	1/2	14.00
ACTI-62-7		7	3-5/8	11-3/4	5/8	13/16 x 1-3/16	1/2	15.30
ACTI-63-3	3-1/2	3	4	11	5/8	11/16 x 1	3/4	14.80
ACTI-63-5		5	4	11	5/8	11/16 x 1-1/16	1/2	14.05
ACTI-63-7		7	4	11	5/8	13/16 x 1-5/16	1/2	14.70
ACTI-64-3	4	3	4-1/2	12	5/8	11/16 x 1	3/4	22.50
ACTI-64-5		5	4-1/2	12	5/8	11/16 x 1-1/16	1/2	21.75
ACTI-67-5	5	5	5-1/16	13-1/4	5/8	11/16 x 1-1/16	7/16	20.00
ACTI-67-7		7	5	13-1/4	5/8	13/16 x 1-5/16	1/2	14.20
ACTI-69-5	6	5	5-1/2	12-13/16	5/8	11/16 x 1-1/16	1/2	29.00
ACTI-69-7		7	5-1/2	12-3/4	5/8	13/16 x 1-3/16	1/2	30.70

ALUMINUM BUS SUPPORTS

TYPE ASCRI

Horizontal Bolted
Pipe or Cable to Insulator

Aluminum alloy bus support for a range of aluminum cable or pipe.
Hex-stops provided for one wrench installation of clamping bolts.
Hardware supplied for CAP mounting.
For PIN mounting, add suffix (P) to catalog number.
Example: ASCRI-53-3P

Castings: 356-T6 Aluminum

Clamping Hardware: Aluminum Alloy

Mounting Hardware: Galvanized Steel

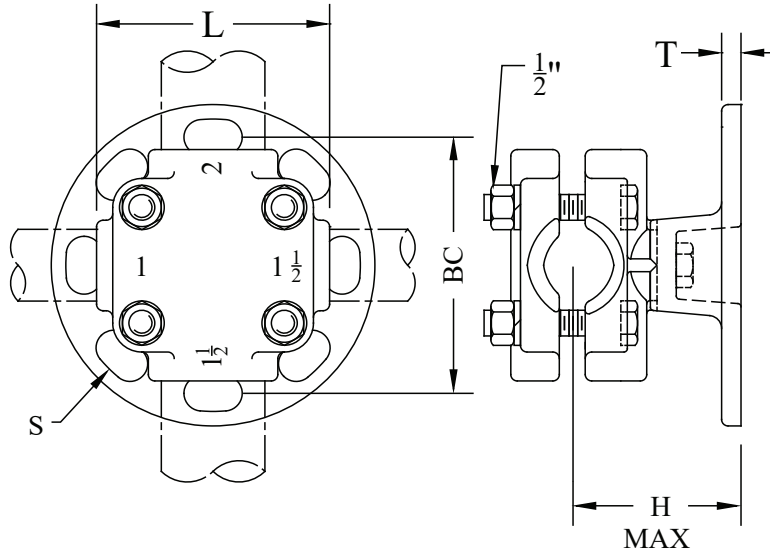

CATALOG NUMBER	CONDUCTOR RANGE		DIMENSIONS - INCHES					WEIGHT (POUNDS)
	CABLE	PIPE	H	L	T	BC	S	
ASCRI-53-3			3	4-1/2	5/16	3	9/16 x 13/16	2.90
ASCRI-53-5	750 - 3000 AAC 666-2515 ACSR	1" O.D. - 2" O.D. .75" - 1-1/2" NPS	3-1/4	4-1/2	3/8	5	11/16 x 1-1/16	3.75
ASCRI-53-7			3-1/4	4-1/2	3/8	7	13/16 x 1-1/16	6.25

ALUMINUM BUS SUPPORTS

TYPE ASTI

Horizontal Bolted
Pipe to Insulator

Aluminum alloy support for aluminum pipe.
Slip or rigid fit is provided by rotating cap members.
Each cap member is provided with a static spring.

Casting Alloy: 356-T6 Aluminum
Clamping Hardware: Aluminum Alloy
Mounting Hardware: Galvanized Steel

Hardware supplied for CAP mounting.
For PIN mounting, add suffix (P) to catalog number.
Example: ASTI-63-3P

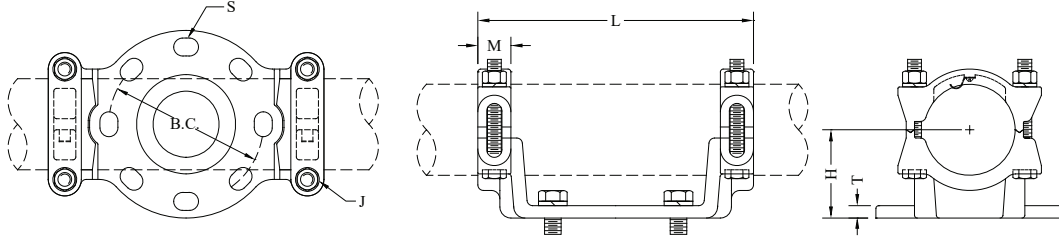

CATALOG NUMBER	PIPE SIZE (NPS)	BOLT CIRCLE	DIMENSIONS - INCHES						WEIGHT (POUNDS)
			H	L	M	S	J	T	
ASTI-30-3	3/4	3	2	8	1-1/2	9/16 x 13/16	1/2	5/16	2.20
ASTI-30-5		5	2	2-3/4	2-1/4	11/16 x 1	3/8	5/16	4.60
ASTI-39-3	1	3	2	7-1/2	1-1/8	9/16 x 13/16	1/2	5/16	2.25
ASTI-39-5		5	2-1/4	9-3/4	1-1/8	11/16 x 1-1/16	1/2	5/16	2.85
ASTI-49-3	1-1/4	3	2-1/4	7-1/8	1-3/8	9/16 x 13/16	1/2	3/8	3.05
ASTI-49-5		5	2-1/4	9-1/2	1-3/8	11/16 x 1-1/8	1/2	3/8	3.90
ASTI-53-3	1-1/2	3	2-1/2	7-1/8	1-3/8	9/16 x 13/16	1/2	3/8	2.60
ASTI-53-5		5	2-1/2	9-5/8	1-3/8	11/16 x 1-1/16	1/2	3/8	3.40
ASTI-58-3	2	3	2-3/4	7-3/8	1-1/2	9/16 x 13/16	1/2	3/8	3.05
ASTI-58-5		5	2-3/4	9-7/8	1-1/2	11/16 x 1-1/16	1/2	3/8	3.65
ASTI-60-3	2-1/2	3	3-1/8	7-1/2	1-1/2	9/16 x 13/16	1/2	3/8	3.90
ASTI-60-5		5	3-1/8	9-5/8	1-1/2	11/16 x 1-1/16	1/2	7/16	4.50
ASTI-60-7		7	3-1/8	13-5/8	1-1/2	13/16 x 1-5/16	1/2	1/2	5.80
ASTI-62-3	3	3	3-5/8	8-1/2	1-1/2	9/16 x 13/16	5/8	1/2	6.20
ASTI-62-5		5	3-5/8	9-3/4	1-1/2	11/16 x 15/16	5/8	1/2	7.00
ASTI-62-7		7	3-5/8	11-3/4	1-1/2	13/16 x 1-3/16	5/8	1/2	8.60
ASTI-63-3	3-1/2	3	4	8-1/4	1-1/2	9/16 x 13/16	5/8	1/2	6.20
ASTI-63-5		5	4	9-3/4	1-1/2	11/16 x 1-1/16	5/8	1/2	7.00
ASTI-63-7		7	4	12-1/2	1-1/2	13/16 x 1-1/8	5/8	9/16	8.50
ASTI-64-3	4	3	4-1/2	8-1/2	1-1/2	9/16 x 13/16	5/8	3/8	6.67
ASTI-64-5		5	4-1/2	10	1-1/2	11/16 x 1-1/16	5/8	7/16	7.80
ASTI-64-7		7	4-1/2	12	1-1/2	13/16 x 1-3/16	5/8	1/2	9.35
ASTI-67-3	5	3	5	8-3/4	1-1/2	9/16 x 1-1/16	5/8	1/2	8.55
ASTI-67-5		5	5	10	1-1/2	11/16 x 1-1/16	5/8	1/2	9.55
ASTI-67-7		7	5	12	1-1/2	13/16 x 1-3/16	5/8	1/2	12.10
ASTI-69-3	6	3	5-5/8	10-1/4	1-3/4	9/16 x 13/16	5/8	15/32	12.00
ASTI-69-5		5	5-5/8	10-1/4	1-3/4	11/16 x 1-1/16	5/8	15/32	12.60
ASTI-69-7		7	5-1/2	12-1/4	1-3/4	13/16 x 1-3/16	5/8	17/32	14.40

ALUMINUM BUS SUPPORTS

TYPE ASTI-R

Horizontal Bolted
Pipe to Insulator

Aluminum alloy bus support for aluminum pipe.
The $\pm 15^\circ$ rotational feature greatly reduces torsional forces during fault conditions.
Slip or rigid fit is provided by rotating the cap members.
Each cap member is provided with a static spring.

Casting Alloy: 356-T6 Aluminum
Clamping Hardware: Aluminum Alloy
Mounting Hardware: Galvanized Steel

Hardware supplied for CAP mounting.
For PIN mounting, add suffix (P) to catalog number.
Example: ASTI-63-3P
Other insulator mounting arrangements are available.
Consult manufacturer for further details or unlisted applications.

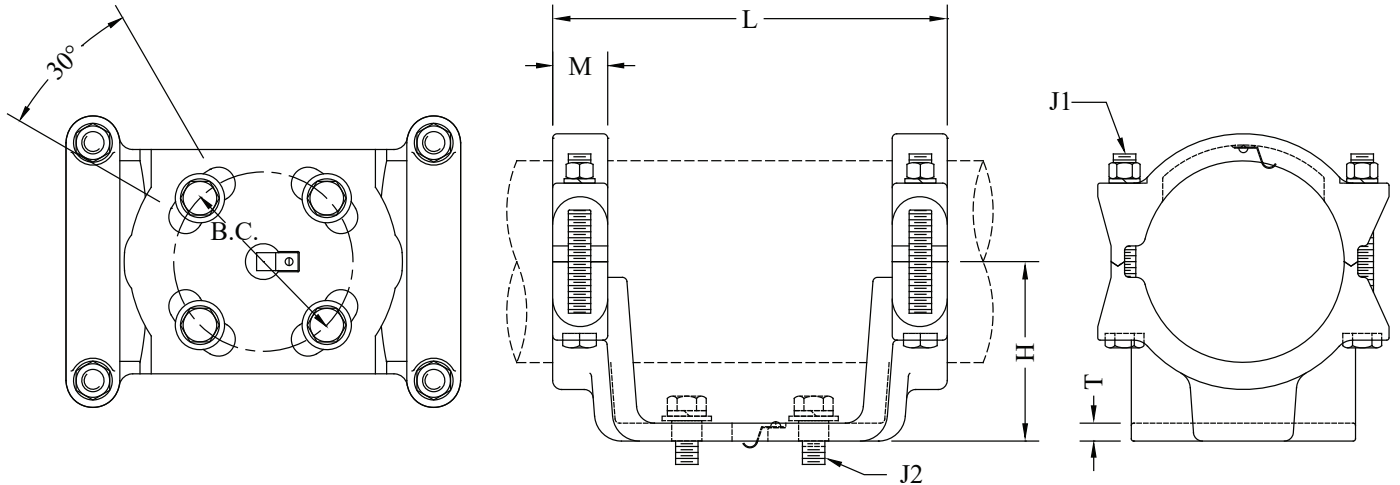

CATALOG NUMBER	PIPE SIZE (NPS)	BOLT CIRCLE	DIMENSIONS - INCHES						WEIGHT (POUNDS)
			H	L	M	J1	J2	T	
ASTI-R-62-3	3	3	3-5/8	8-1/2	1-1/2	5/8	1/2	1/2	6.60
ASTI-R-62-5		5	3-5/8	9-3/4	1-1/2	5/8	5/8	1/2	7.40
ASTI-R-63-3	3 1/2	3	4	8-1/4	1-1/2	5/8	1/2	1/2	6.40
ASTI-R-63-5		5	4	9-3/4	1-1/2	5/8	5/8	1/2	7.40
ASTI-R-63-7		7	4	12-1/2	1-1/2	5/8	3/4	9/16	11.75
ASTI-R-64-3	4	3	4-1/2	8-1/2	1-1/2	5/8	1/2	3/8	7.15
ASTI-R-64-5		5	4-1/2	10	1-1/2	5/8	5/8	1/2	8.15
ASTI-R-64-7		7	4-1/2	12	1-1/2	5/8	3/4	1/2	12.50
ASTI-R-67-5	5	5	5	10	1-1/2	5/8	5/8	1/2	9.90
ASTI-R-67-7		7	5	12	1-1/2	5/8	3/4	1/2	15.25
ASTI-R-69-5	6	5	5-1/2	10-1/4	1-3/4	5/8	5/8	1/2	14.65
ASTI-R-69-7		7	5-1/2	12-1/4	1-3/4	5/8	3/4	17/32	17.55
ASTI-R-71-7	8	7	7	14	2	3/4	3/4	9/16	28.55

ALUMINUM BUS SUPPORTS

TYPE ASWH

Horizontal Weldment
Pipe to Insulator

Aluminum alloy weldment bus support for aluminum pipe.

Designed for slip or rigid fit applications.

When rigid fit is required, you must weld the hooks to the pipe.

Delete the -SE suffix to eliminate the static spring.

Hardware supplied for cap mounted.

For pin mounted, add suffix (P) to catalog number, Example: ASWH-58-5P

Casting Alloy: 356-T6 Aluminum

Mounting Hardware: Galvanized Steel

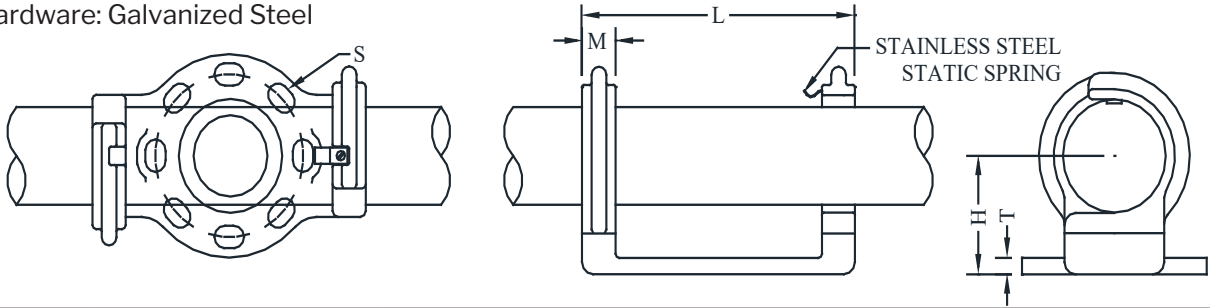

CATALOG NUMBER	PIPE SIZE (NPS)	BOLT CIRCLE	DIMENSIONS - INCHES					WEIGHT (POUNDS)
			H	L	T	M	S	
ASWH-30-3-SE	3/4	3	2	5-1/2	9/32	1/2	9/16 x 3/4	1.15
ASWH-30-5-SE		5	2-1/4	8	3/8	5/8	11/16 x 1	2.00
ASWH-39-3-SE	1	3	2	6	5/16	3/4	9/16 x 13/16	1.15
ASWH-39-5-SE		5	2-1/4	8-1/4	3/8	3/4	11/16 x 1	2.25
ASWH-49-3-SE	1-1/4	3	2-1/4	7-1/4	1/2	1-1/8	9/16 x 13/16	2.95
ASWH-49-5-SE		5	2-1/4	9-1/4	1/2	1-1/8	11/16 x 15/16	3.45
ASWH-53-3-SE	1-1/2	3	2-1/2	7-1/4	9/16	1-1/8	9/16 x 13/16	2.80
ASWH-53-5-SE		5	2-1/2	9-1/4	1/2	1-1/8	11/16 x 15/16	3.70
ASWH-58-3-SE	2	3	2-3/4	7-1/4	9/16	1-1/8	9/16 x 13/16	2.95
ASWH-58-5-SE		5	2-3/4	9-1/4	9/16	1-1/8	11/16 x 15/16	3.80
ASWH-60-3-SE	2-1/2	3	3-1/8	7-1/4	1/2	1-3/16	9/16 x 13/16	3.45
ASWH-60-5-SE		5	3-1/8	9-1/4	9/16	1-1/8	11/16 x 15/16	4.25
ASWH-60-7-SE		7	3-1/8	12-1/2	1/2	1-1/8	13/16 x 1-1/8	6.50
ASWH-62-3-SE	3	3	3-5/8	7-1/4	9/16	1-1/8	9/16 x 13/16	3.95
ASWH-62-5-SE		5	3-5/8	9-1/4	1/2	1-1/8	11/16 x 15/16	4.75
ASWH-62-7-SE		7	3-5/8	12-1/2	1/2	1-1/4	13/16 x 1-1/8	7.00
ASWH-63-3-SE	3-1/2	3	4	7-1/4	1/2	1-1/8	9/16 x 13/16	3.95
ASWH-63-5-SE		5	4	9-1/4	3/8	1-1/8	11/16 x 15/16	4.77
ASWH-63-7-SE		7	4	12-1/2	1/2	1-3/16	13/16 x 1-1/8	6.99
ASWH-64-3-SE	4	3	4-1/2	7-1/4	9/16	1-1/8	9/16 x 13/16	3.95
ASWH-64-5-SE		5	4-1/2	9-1/4	1/2	1-3/16	11/16 x 15/16	4.75
ASWH-64-7-SE		7	4-1/2	12-1/2	1/2	1-1/8	13/16 x 1-1/8	7.00
ASWH-67-3-SE	5	3	5	7-5/8	1/2	1-1/2	9/16 x 13/16	5.95
ASWH-67-5-SE		5	5	9-5/8	1/2	1-1/2	11/16 x 15/16	6.80
ASWH-67-7-SE		7	5	11-1/2	1/2	1-3/8	13/16 x 1-5/16	9.60
ASWH-69-3-SE	6	3	5-1/2	7-5/8	1/2	1-1/2	9/16 x 3/4	5.95
ASWH-69-5-SE		5	5-1/2	9-5/8	1/2	1-1/2	11/16 x 15/16	6.80
ASWH-69-7-SE		7	5-1/2	12-7/8	1/2	1-1/2	13/16 x 1-1/8	9.00

ALUMINUM BUS SUPPORTS

TYPE AVCA

Horizontal Bolted
One Cable to Insulator

Aluminum alloy bus support for aluminum cable.
Hex-stops provided for one-wrench installation of clamping bolts.

Hardware supplied for CAP mounting.
For PIN mounting, add suffix (P) to catalog number.
Example: AVCA-24-3P

Casting Alloy: 356-T6 Aluminum
Clamping Hardware: Aluminum
Mounting Hardware: Galvanized Steel

*AVCA-1139 Bus Support will also accept a range of pipe 1/4"-1" NPS

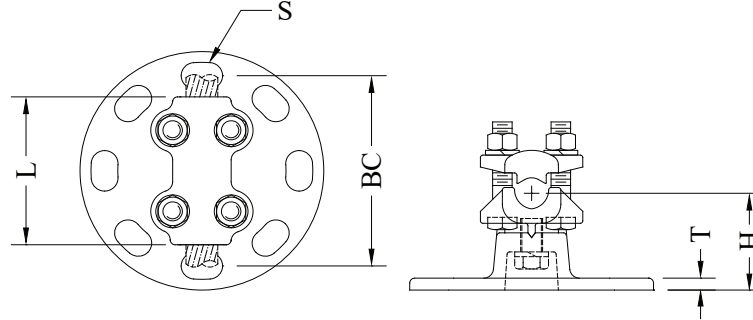

CATALOG NUMBER	CONDUCTOR RANGE		DIMENSIONS - INCHES					WEIGHT (POUNDS)
	AAC	ACSR	H	L	BC	S	T	
AVCA-13-3	#4 - 266 MCM	#4 - 4/0 MCM	1-3/4	3	3	9/16 x 13/16	5/16	1.90
AVCA-13-5			1-13/16	3	5	11/16 x 1	3/8	2.65
AVCA-20-3	4/0 - 500 MCM	4/0 - 397 MCM	2-5/8	3-1/2	3	9/16 x 13/16	5/16	2.30
AVCA-20-5			2-7/8	3-1/2	5	11/16 x 1	5/16	3.15
AVCA-24-3	350 - 650 MCM	336 - 556 MCM	2-7/8	4	3	9/16 x 13/16	5/16	2.30
AVCA-24-5			2-7/8	4	5	11/16 x 1	3/8	3.15
AVCA-34-3	550 - 1000 MCM	477 - 795 MCM	3	4	3	9/16 x 13/16	3/8	2.60
AVCA-34-5			3	4	5	11/16 x 1-1/16	3/8	3.50
AVCA-39-3	874 - 1272 MCM	715 - 1113 MCM	2-7/8	4-1/4	3	9/16 x 13/16	5/16	2.85
AVCA-39-5			3-3/16	4-1/4	5	11/16 x 1-1/16	3/8	3.80
AVCA-43-3	1250 - 1590 MCM	1113 - 1431 MCM	3-1/4	4-1/2	3	9/16 x 13/16	5/16	3.70
AVCA-43-5			3-3/8	4-1/2	5	11/16 x 1	3/8	4.60
AVCA-46-3	1250 - 1800 MCM	1113 - 1590 MCM	3-1/8	4-3/4	3	9/16 x 13/16	5/16	3.75
AVCA-46-5			3-3/8	4-3/4	5	11/16 x 1-1/16	3/8	4.60
AVCA-51-3	1500 - 2500 MCM	1351 - 2156 MCM	3-3/8	5	3	9/16 x 13/16	5/16	4.25
AVCA-51-5			3-5/8	5	5	11/16 x 1	3/8	5.10
AVCA-52-3	2250 - 2500 MCM	-----	3-1/2	3-1/8	3	9/16 x 13/16	3/8	2.90
AVCA-52-5			3-7/16	3-1/8	5	11/16 x 1-1/16	3/8	3.80
AVCA-1020-3	#1 - 500 MCM	#2 - 397 MCM	2-5/8	3-1/2	3	9/16 x 13/16	5/16	2.30
AVCA-1020-5			2-15/16	3-1/2	5	11/16 x 1	3/8	3.10
AVCA-1139-3	4/0 - 1351.5 MCM	4/0 - 1272(45/7) MCM	2-7/8	4-1/4	3	9/16 x 13/16	5/16	3.10
AVCA-1139-5			3-3/8	4-1/4	5	11/16 x 1	3/8	4.05
AVCA-2743-3	750 - 1590 MCM	605 - 1431 MCM	3-1/4	4-1/2	3	9/16 x 13/16	5/16	3.70
AVCA-2743-5			3-1/2	4-1/2	5	11/16 x 1	3/8	4.55
AVCA-3653-3	1100 - 2500 MCM	1113 - 2300 MCM	3-1/2	4	3	9/16 x 13/16	5/16	3.70
AVCA-3653-5			3-3/4	4	5	11/16 x 1-1/16	3/8	4.55

ALUMINUM BUS SUPPORTS

TYPE AVCA2

Horizontal Bolted

Two Cables to Insulator

Aluminum alloy bus support for two parallel aluminum cables.
Hex-stops provided for one wrench installation of clamping bolts.

Hardware supplied for CAP mounting.
For PIN mounting, add suffix (P) to catalog number.

Example: AVCA2-24-3P

*AVCA2-1139 Bus Support will also accept a range of pipe 1/4"-1" NPS

Casting Alloy: 356-T6 Aluminum
Clamping Hardware: Aluminum Alloy
Mounting Hardware: Galvanized Steel

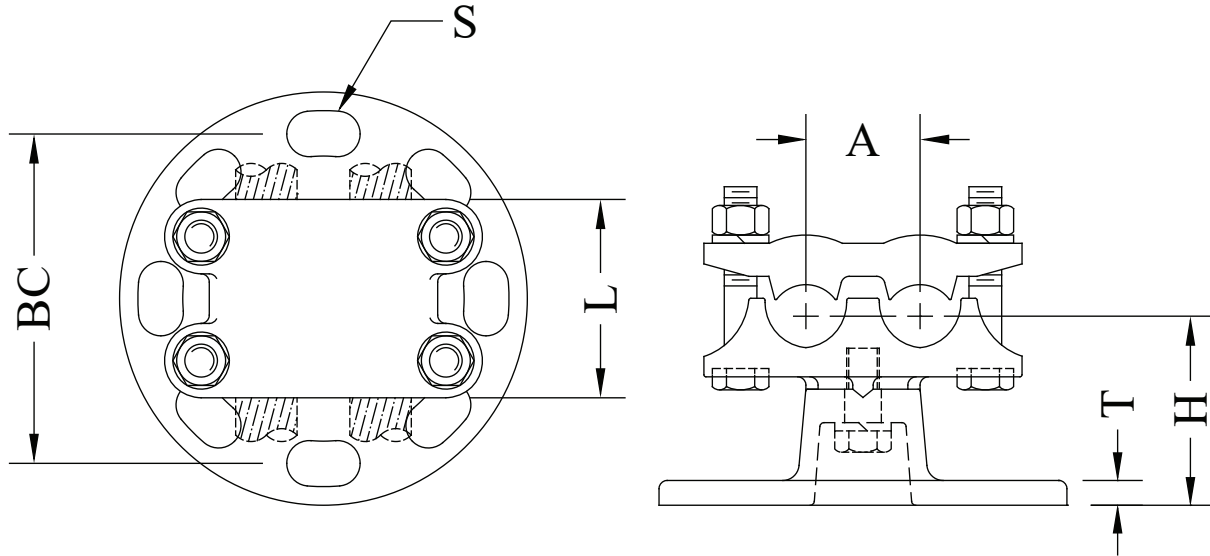

CATALOG NUMBER	CONDUCTOR RANGE		DIMENSIONS - INCHES						WEIGHT (POUNDS)
	AAC	ACSR	H	L	A	BC	S	T	
AVCA2-24-3	397 - 750 MCM	336 - 556 MCM	2-3/8	2-5/8	1-3/8	3	9/16 x 13/16	3/8	2.70
AVCA2-24-5			2-3/8	2-5/8	1-3/8	5	11/16 x 1	3/8	
AVCA2-34-3	550 - 1000 MCM	477 - 795 MCM	2-3/4	3	1-3/4	3	9/16 x 13/16	5/16	3.15
AVCA2-34-5			3	3	1-3/4	5	11/16 x 1-1/16	3/8	
AVCA2-39-3	874 - 1272 MCM	715.5 - 1113 MCM	3-1/8	3-3/4	1-11/16	3	9/16 x 13/16	5/16	3.70
AVCA2-39-5			3-1/8	3-3/4	1-11/16	5	11/16 x 1-1/16	3/8	
AVCA2-43-3	1192 - 1590 MCM	1033 - 1431 MCM	3-1/4	4	2	3	9/16 x 13/16	5/16	4.20
AVCA2-43-5			3-1/2	4	2	5	11/16 x 1-1/16	3/8	
AVCA2-51-3	1500 - 2500 MCM	1351 - 2156 MCM	3-5/8	4-1/2	2-1/4	3	9/16 x 13/16	5/16	5.90
AVCA2-51-5			3-5/8	4-1/2	2-1/4	5	11/16 x 1	3/8	
AVCA2-1139-3	4/0 - 1300 MCM	4/0 - 1113 MCM	2-7/8	3-3/4	1-11/16	3	9/16 x 13/16	5/16	3.60
AVCA2-1139-5			2-7/8	3-3/4	1-11/16	5	11/16 x 1-1/16	3/8	

ALUMINUM BUS SUPPORTS

TYPE AVTI

Vertical Bolted
Pipe to Insulator

Aluminum alloy bus support for vertical dead ending aluminum pipe.
Clamping bolts have hex-stops for one-wrench installation.

Hardware supplied for CAP mounting.
For PIN mounting, add suffix (P) to catalog number.
EXAMPLE: AVTI-58-5P

Casting Alloy: 356-T6 Aluminum
Clamping Hardware: Aluminum Alloy
Mounting Hardware: Galvanized Steel

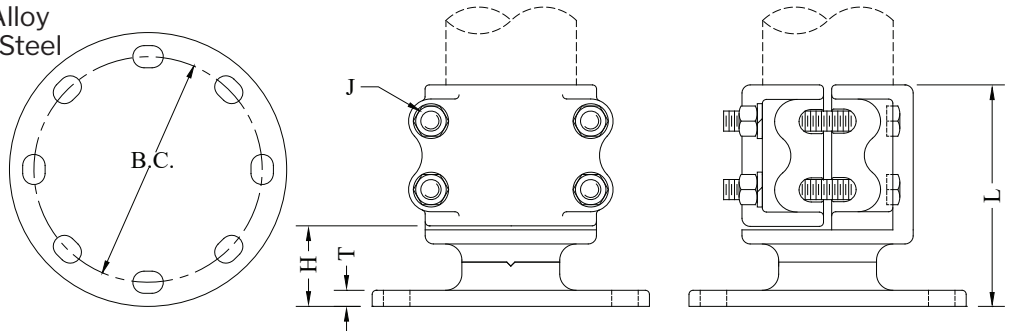

CATALOG NUMBER	PIPE SIZE (NPS)	BOLT CIRCLE	DIMENSIONS - INCHES				WEIGHT (POUNDS)
			H	L	J	T	
AVTI-30-3	3/4	3	1-9/16	3-15/16	1/2	5/16	2.20
AVTI-30-5		5	1-9/16	3-15/16	1/2	5/8	2.70
AVTI-39-3	1	3	2-3/16	6-5/16	1/2	3/8	2.70
AVTI-39-5		CONTACT FACTORY FOR DETAILS					
AVTI-49-3	1-1/4	3	1-3/4	4-3/4	1/2	3/8	2.90
AVTI-49-5		5	1-3/4	4-3/4	1/2	3/8	3.50
AVTI-53-3	1-1/2	3	2-3/8	5-5/8	1/2	7/16	3.30
AVTI-53-5		5	7/8	4	1/2	3/8	4.10
AVTI-58-3	2	3	2-3/8	5-7/8	1/2	3/8	3.80
AVTI-58-5		5	2	5-1/2	1/2	3/8	4.35
AVTI-60-3	2-1/2	3	2-1/2	6	1/2	7/16	4.30
AVTI-60-5		5	2-3/8	6-7/8	1/2	7/16	4.10
AVTI-62-3	3	3	2-5/8	6-5/8	1/2	7/16	5.40
AVTI-62-5		5	2-3/8	7-7/8	5/8	7/16	6.50
AVTI-62-7		7	2-7/16	6-9/16	5/8	1/2	9.00
AVTI-63-3	3-1/2	CONTACT FACTORY FOR DETAILS					
AVTI-63-5		5	2-3/8	6-7/8	5/8	1/2	9.05
AVTI-63-7		7	2-3/8	6-7/8	5/8	1/2	10.65
AVTI-64-3	4	CONTACT FACTORY FOR DETAILS					
AVTI-64-5		5	2-1/4	7-3/4	5/8	7/16	8.00
AVTI-64-7		CONTACT FACTORY FOR DETAILS					
AVTI-67-5	5	5	2-1/2	8-1/4	5/8	1/2	12.20
AVTI-67-7		7	2-1/2	8-1/4	5/8	1/2	13.95
AVTI-69-5	6	5	3-1/8	9-1/8	5/8	1/2	17.90
AVTI-69-7		7	3-1/8	9-1/8	5/8	1/2	19.65

ALUMINUM BUS SUPPORTS

TYPE AXCTO

Bolted Expansion
Pipe to Insulator

Aluminum alloy, horizontal bolted, expansion bus support for aluminum pipe.
Hardware supplied for CAP mounting.
For PIN mounting, add suffix (P) to catalog number.
Example AXCTO-63-5P.
For welded applications, see WXCTO Page 17.

Casting Alloy: 356-T6 Aluminum
Clamping Hardware: Aluminum Alloy
Mounting Hardware: Galvanized Steel
Laminated Straps: 1100-0 Aluminum

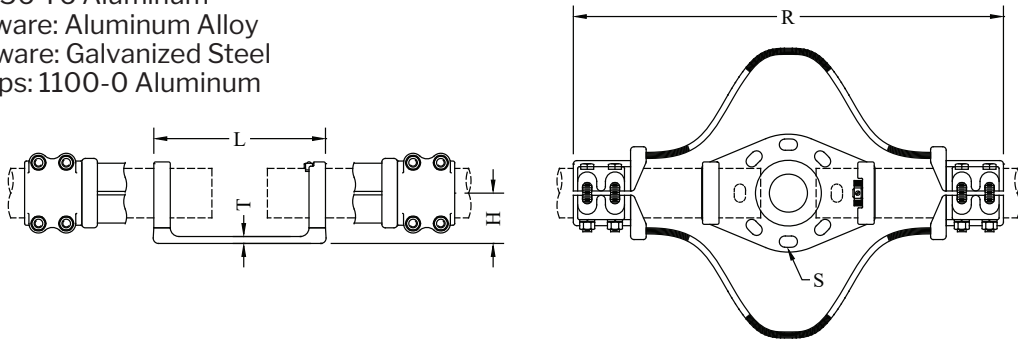

CATALOG NUMBER	PIPE SIZE (NPS)	BOLT CIRCLE	DIMENSIONS - INCHES					WEIGHT (POUNDS)
			H	L	R	S	T	
AXCTO-30-3	3/4	3	2	7-1/4	16-3/4	9/16 x 13/16	5/16	4.80
AXCTO-30-5		5	2-1/4	9-1/4	19	11/16 x 1-1/8	5/16	5.25
AXCTO-39-3	1	3	2	5-3/4	16-3/4	9/16 x 13/16	5/16	5.45
AXCTO-39-5		5	2	8	19	11/16 x 1-1/8	5/16	6.00
AXCTO-49-3	1-1/4	3	2-1/4	7-1/8	21-1/4	9/16 x 13/16	3/8	8.70
AXCTO-49-5		5	2-1/4	9-1/2	23-1/4	11/16 x 1-1/8	3/8	9.50
AXCTO-53-3	1-1/2	3	2-1/2	7-1/4	20-1/2	9/16 x 13/16	1/2	9.65
AXCTO-53-5		5	2-1/2	9-1/8	23	11/16 x 15/16	1/2	10.75
AXCTO-58-3	2	3	2-3/4	7-1/4	22-1/4	9/16 x 13/16	1/2	12.60
AXCTO-58-5		5	2-3/4	9-1/8	23-3/4	11/16 x 15/16	1/2	13.30
AXCTO-60-3	2-1/2	3	3-1/8	7-1/4	22-1/4	9/16 x 13/16	1/2	16.25
AXCTO-60-5		5	3-1/8	9-1/4	23-3/4	11/16 x 15/16	1/2	17.35
AXCTO-62-3	3	3	3-5/8	7-1/8	24	9/16 x 13/16	1/2	19.75
AXCTO-62-5		5	3-5/8	9-1/8	25-3/4	11/16 x 15/16	1/2	21.70
AXCTO-62-7		7	3-5/8	12-3/8	31	13/16 x 1-5/16	1/2	27.70
AXCTO-63-3	3-1/2	3	4	7-1/4	24-3/4	9/16 x 13/16	1/2	24.95
AXCTO-63-5		5	4	9-1/4	26-3/4	11/16 x 15/16	1/2	26.40
AXCTO-63-7		7	4	12-1/2	30	13/16 x 1-5/16	1/2	49.15
AXCTO-64-3	4	3	4-1/2	7-1/8	25-3/4	9/16 x 13/16	1/2	27.35
AXCTO-64-5		5	4-1/2	11-3/4	30-1/4	11/16 x 1	3/8	33.80
AXCTO-64-7		7	4-1/2	12-1/2	31	13/16 x 1-5/16	1/2	34.55
AXCTO-67-5	5	5	5	14	38	11/16 x 1-1/16	3/8	60.45
AXCTO-67-7		7	5	13-1/2	38-3/4	13/16 x 1-5/16	1/2	63.70
AXCTO-69-5	6	5	5-1/2	14	38-1/4	11/16 x 1-1/16	3/8	84.00
AXCTO-69-7		7	5-1/2	12-3/4	37-1/2	13/16 x 1-5/16	1/2	86.95

ALUMINUM BUS SUPPORTS

TYPE WCTI

Horizontal Weldment
Pipe to insulator

Aluminum alloy, horizontal weldment, bus support for aluminum pipe.
Designed for slip or rigid fit applications.
When rigid fit is required you must weld the rings to the pipe.
Hardware supplied for CAP mounting.
For PIN mounting, add suffix (P) to catalog number.
Example: WCTI-58-3P

Casting Alloy: 356-T6 Aluminum
Mounting Hardware: Galvanized Steel

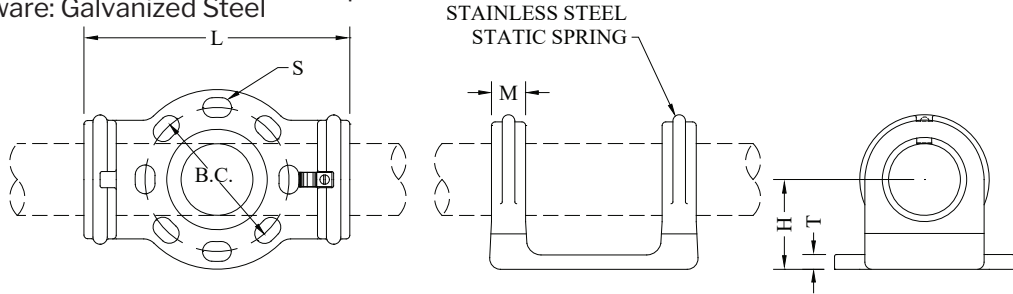

CATALOG NUMBER	PIPE SIZE (NPS)	BOLT CIRCLE	DIMENSIONS - INCHES					WEIGHT (POUNDS)
			H	L	M	S	T	
WCTI-30-3	3/4	3	2	7-1/4	1-1/8	9/16 x 13/16	3/8	2.95
WCTI-30-5		5	2-1/4	9-1/4	1-1/8	11/16 x 1	3/8	3.80
WCTI-39-3	1	3	2	5-3/4	5/8	9/16 x 13/16	5/16	1.40
WCTI-39-5		5	2	8	5/8	11/16 x 15/16	5/16	2.30
WCTI-49-3	1-1/4	3	2-1/4	7-1/4	1-1/8	9/16 x 13/16	1/2	2.95
WCTI-49-5		5	2-3/8	9-1/4	1-1/8	11/16 x 15/16	1/2	3.80
WCTI-53-3	1-1/2	3	2-1/2	7-1/4	1-1/8	9/16 x 13/16	1/2	3.45
WCTI-53-5		5	2-1/2	9-1/4	1-1/8	11/16 x 15/16	9/16	4.30
WCTI-58-3	2	3	2-3/4	7-1/4	1-3/16	9/16 x 13/16	1/2	3.95
WCTI-58-5		5	2-3/4	9-1/4	1-1/4	11/16 x 15/16	1/2	4.80
WCTI-60-3	2-1/2	3	3-1/8	7-1/4	1-1/8	9/16 x 13/16	1/2	3.95
WCTI-60-5		5	3-1/8	9-1/4	1-1/8	11/16 x 15/16	1/2	4.80
WCTI-62-3	3	3	3-5/8	7-1/4	1-3/16	9/16 x 13/16	1/2	3.95
WCTI-62-5		5	3-5/8	9-1/4	1-3/16	11/16 x 15/16	9/16	4.80
WCTI-62-7		7	3-5/8	12-1/2	1-3/16	13/16 x 1-1/8	1/2	7.00
WCTI-63-3	3-1/2	3	4	7-1/4	1-3/16	9/16 x 13/16	1/2	4.95
WCTI-63-5		5	4	9-1/4	1-3/16	11/16 x 15/16	9/16	5.80
WCTI-63-7		7	4	12-1/2	1-1/4	13/16 x 1-1/8	1/2	8.00
WCTI-64-3	4	3	4-1/2	7-1/4	1-3/16	9/16 x 13/16	1/2	5.45
WCTI-64-5		5	4-1/2	9-1/4	1-3/16	11/16 x 15/16	9/16	6.30
WCTI-64-7		7	4-1/2	12-1/2	1-1/4	13/16 x 1-1/8	1/2	8.50
WCTI-67-3	5	3	5	7-3/8	1-1/2	9/16 x 13/16	1/2	6.95
WCTI-67-5		5	5	9-1/2	1-1/2	11/16 x 15/16	9/16	7.80
WCTI-67-7		7	5	12-3/4	1-1/2	13/16 x 1-1/8	1/2	10.00
WCTI-69-3	6	3	5-1/2	8	2	9/16 x 13/16	1/2	8.45
WCTI-69-5		5	5-1/2	10	2	11/16 x 15/16	1/2	9.30
WCTI-69-7		7	5-1/2	13-1/4	2	13/16 x 1-1/8	1/2	11.50

ALUMINUM BUS SUPPORTS

TYPE WRTI

Horizontal Weldment
Pipe to Insulator

Aluminum alloy, horizontal weldment, bus support for aluminum pipe.
Designed for rigid applications.

Hardware supplied for CAP mounting.
For PIN mounting, add suffix (P) to catalog number.
Example: WRTI-58-3P

Casting Alloy: 356-T6 Aluminum
Mounting Hardware: If Needed

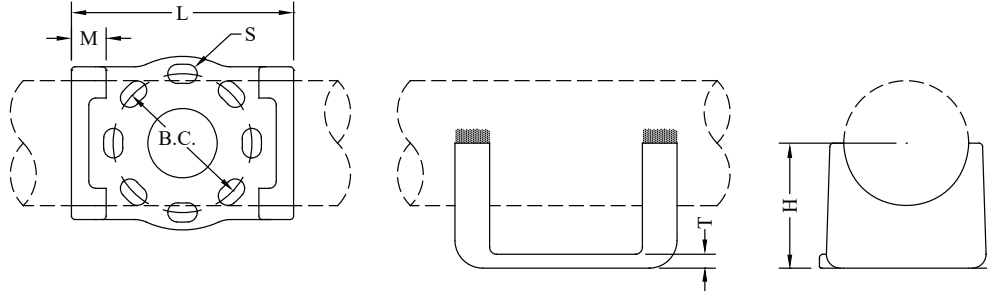

CATALOG NUMBER	PIPE SIZE (NPS)	BOLT CIRCLE	DIMENSIONS - INCHES					WEIGHT (POUNDS)
			H	L	M	S	T	
WRTI-30-3	3/4	3	2	5-1/2	1/2	9/16 x 13/16	9/32	0.80
WRTI-30-5		5	2-1/4	9-1/4	1/2	11/16 x 1	1/2	1.10
WRTI-39-3	1	3	2	5-1/2	5/8	9/16 x 13/16	5/16	0.90
WRTI-39-5		5	2	9-1/4	5/8	11/16 x 1	1/2	1.25
WRTI-49-3	1-1/4	3	2-1/4	5-1/2	5/8	9/16 x 13/16	9/32	1.15
WRTI-49-5		5	2-3/8	9-1/4	1	11/16 x 1-1/16	1/2	1.75
WRTI-53-3	1-1/2	3	2-1/2	5-1/2	5/8	9/16 x 13/16	3/8	1.45
WRTI-53-5		5	2-1/2	9-1/4	5/8	11/16 x 1	1/2	1.85
WRTI-58-3	2	3	2-3/4	5-3/4	3/4	9/16 x 13/16	9/32	1.65
WRTI-58-5		5	2-3/4	7-1/2	3/4	11/16 x 15/16	3/8	2.25
WRTI-60-3	2-1/2	3	3-1/8	6-1/4	1	9/16 x 13/16	5/16	1.90
WRTI-60-5		5	3-1/8	8	1	11/16 x 1-1/16	3/8	2.75
WRTI-62-3	3	3	3-5/8	5-3/4	5/8	9/16 x 13/16	3/8	2.40
WRTI-62-5		5	3-5/8	9	1-1/8	11/16 x 15/16	7/16	4.00
WRTI-62-7		7	3-5/8	11-1/4	1-1/8	13/16 x 1-3/16	1/2	7.00
WRTI-63-3	3-1/2	3	4	6	5/8	9/16 x 13/16	3/8	2.40
WRTI-63-5		5	4	7-1/2	1-1/8	11/16 x 15/16	7/16	2.75
WRTI-63-7		7	4	10-1/2	1-1/8	13/16 x 1-3/16	1/2	7.00
WRTI-64-3	4	3	4-1/2	6-3/4	1	9/16 x 13/16	3/8	2.65
WRTI-64-5		5	4-1/2	8	1-1/4	11/16 x 1-1/16	1/2	5.75
WRTI-64-7		7	4-1/2	11-1/8	3/4	13/16 x 1-3/16	1/2	6.50
WRTI-67-3	5	3	5	6-1/4	5/8	9/16 x 13/16	7/16	4.45
WRTI-67-5		5	5	8-1/4	1-1/4	11/16 x 1-1/16	1/2	6.75
WRTI-67-7		7	5	12	1-1/4	13/16 x 1-3/16	1/2	7.85
WRTI-69-3	6	3	5-1/2	8-3/4	1	9/16 x 13/16	7/16	3.45
WRTI-69-5		5	5-1/2	8-3/4	1	11/16 x 1-1/16	7/16	4.25
WRTI-69-7		7	5-1/2	13-1/4	2	13/16 x 1-1/8	1/2	11.50

ALUMINUM BUS SUPPORTS

TYPE WTSI
Horizontal Weldment
Pipe to Insulator

Aluminum alloy bus support for aluminum pipe.
Can be used as rigid fit, slip fit, or rigid coupler.

Hardware supplied for CAP mounting.
For PIN mounting, add suffix (P) to catalog number.

Casting Alloy: 356-T6 Aluminum
Mounting Hardware: Galvanized Steel

Example: WTSI-60-3P

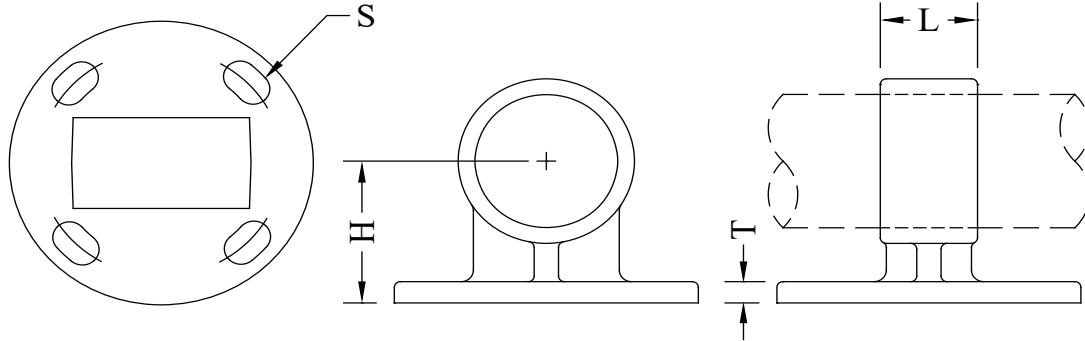

CATALOG NUMBER	PIPE SIZE (NPS)	BOLT CIRCLE	DIMENSIONS - INCHES				WEIGHT (POUNDS)
			H	L	S	T	
WTSI-30-3	3/4	3	2	1-1/2	9/16 x 13/16	3/8	0.50
WTSI-30-5		5	2-1/4	1-1/2	11/16 x 1	3/8	1.45
WTSI-39-3	1	3	2	1-1/2	9/16 x 13/16	5/16	0.65
WTSI-39-5		5	2-1/4	1-1/2	11/16 x 1	3/8	2.20
WTSI-49-3	1-1/4	3	2-1/4	1-3/4	9/16 x 13/16	3/8	1.95
WTSI-49-5		5	2-1/4	1-3/4	11/16 x 1	3/8	2.50
WTSI-53-3	1-1/2	3	2-1/2	1-3/4	9/16 x 13/16	5/16	1.70
WTSI-53-5		5	2-1/2	1-3/4	9/16 x 1	5/16	2.85
WTSI-58-3	2	3	2-3/4	2	9/16 x 13/16	3/8	2.40
WTSI-58-5		5	2-3/4	2	11/16 x 1	3/8	3.00
WTSI-60-3	2-1/2	3	3-1/8	2	9/16 x 13/16	3/8	2.40
WTSI-60-5		5	3-1/8	2	11/16 x 1-1/16	7/16	3.00
WTSI-62-3	3	3	3-5/8	2-1/2	9/16 x 13/16	3/8	3.65
WTSI-62-5		5	3-5/8	2-1/2	11/16 x 1-1/16	3/8	4.25
WTSI-62-7		7	3-5/8	2-1/2	13/16 x 1-5/16	1/2	6.25
WTSI-63-3	3-1/2	3	4	3	9/16 x 13/16	3/8	3.65
WTSI-63-5		5	4	3	11/16 x 1-3/8	1/2	4.25
WTSI-63-7		7	4	3	13/16 x 1-3/16	1/3	5.50
WTSI-64-3	4	3	4-1/2	3	9/16 x 13/16	3/8	3.40
WTSI-64-5		5	4-1/2	3-1/2	11/16 x 1-1/2	1/2	5.25
WTSI-64-7		7	4-1/2	3	13/16 x 1-1/4	1/2	6.85
WTSI-67-5	5	5	5	4	11/16 x 1-3/8	1/2	5.75
WTSI-67-7		7	5-1/8	4	13/16 x 1-5/16	1/2	6.35

ALUMINUM BUS SUPPORTS

TYPE WVTI

Vertical Weldment
Pipe to Insulator

Aluminum alloy vertical weldment bus support for pipe.

Hardware supplied for CAP mounting.

For PIN mounting, add suffix (P) to catalog number.

Casting Alloy: 356-T6 Aluminum

Mounting Hardware: Galvanized Steel

Example: WVTI-62-5P

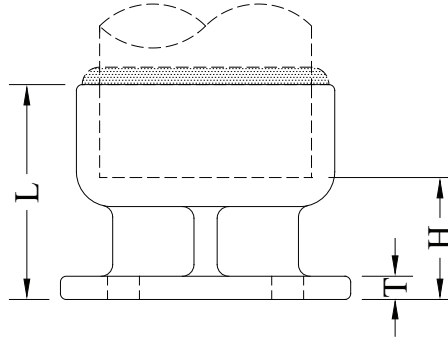
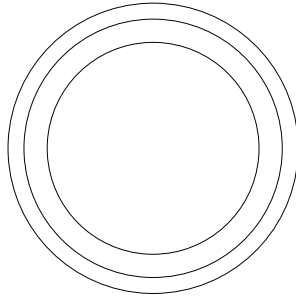

CATALOG NUMBER	PIPE SIZE (NPS)	BOLT CIRCLE	DIMENSIONS - INCHES				WEIGHT (POUNDS)
			H	L	J	T	
WVTI-30-3	3/4	3	5/16	1-5/16	1/2	5/16	1.10
WVTI-30-5		5	5/16	1-5/16	5/8	3/8	1.60
WVTI-39-3	1	3	1-1/4	2-3/16	1/2	5/16	1.40
WVTI-39-5		5	1-1/4	2-3/16	5/8	3/8	1.80
WVTI-49-3	1-1/4	3	1-9/16	2-9/16	1/2	5/16	1.40
WVTI-49-5		5	1-1/8	2	5/8	3/8	2.00
WVTI-53-3	1-1/2	3	1-3/4	3-1/8	1/2	5/16	1.65
WVTI-53-5		5	7/8	1-3/4	5/8	5/16	2.25
WVTI-58-3	2	3	2-1/16	3-13/16	1/2	5/16	2.40
WVTI-58-5		5	1-1/8	2	5/8	3/8	2.00
WVTI-60-3	2-1/2	3	2-3/8	4-3/8	1/2	3/8	2.70
WVTI-60-5		5	2	4	5/8	1/2	3.75
WVTI-62-3	3	3	2-5/8	5-1/8	1/2	1/2	4.20
WVTI-62-5		5	2-1/2	4-1/4	5/8	1/2	4.75
WVTI-62-7		7	2-1/2	5	3/4	1/2	4.90
WVTI-63-3	3-1/2	3	2-5/8	5-1/8	1/2	1/2	4.20
WVTI-63-5		5	2	4-1/2	5/8	1/2	4.25
WVTI-63-7		7	1/2	2-1/8	3/4	1/2	3.90
WVTI-64-3	4	3	2-3/8	4-3/8	1/2	3/8	4.20
WVTI-64-5		5	2-9/16	4-9/16	5/8	1/2	7.05
WVTI-64-7		7	2-1/2	4-1/2	3/4	1/2	7.85
WVTI-67-3	5	3	2-1/16	4-9/16	1/2	5/16	8.90
WVTI-67-5		5	3	5-1/2	5/8	1/2	10.25
WVTI-67-7		7	3-1/2	6	3/4	1/2	14.05
WVTI-69-5	6	5	3	6	5/8	1/2	9.80
WVTI-69-7		7	3	6	3/4	1/2	11.50

ALUMINUM BUS SUPPORTS

TYPE WXCTO

Weldment Expansion
Pipe to Insulator

Casting Alloy: 356-T6 Aluminum
Mounting Hardware: Galvanized Steel
Laminated Straps: 1100-0 Aluminum

Aluminum alloy, horizontal weldment, expansion bus support for aluminum pipe. Hardware supplied for CAP mounting. For PIN mounting, add suffix (P) to catalog number. Example WXCTO-63-5P

Add suffix (H) & (-EP) to catalog number for SCH 80 pipe, when welded end plugs are desired. Example: WXCTO-58H-3-EP

Add suffix (-EP) for weldment end plugs, for NPS.

Example: WXCTO-58-3-EP

For bolted applications, see AXCTO Page 11.

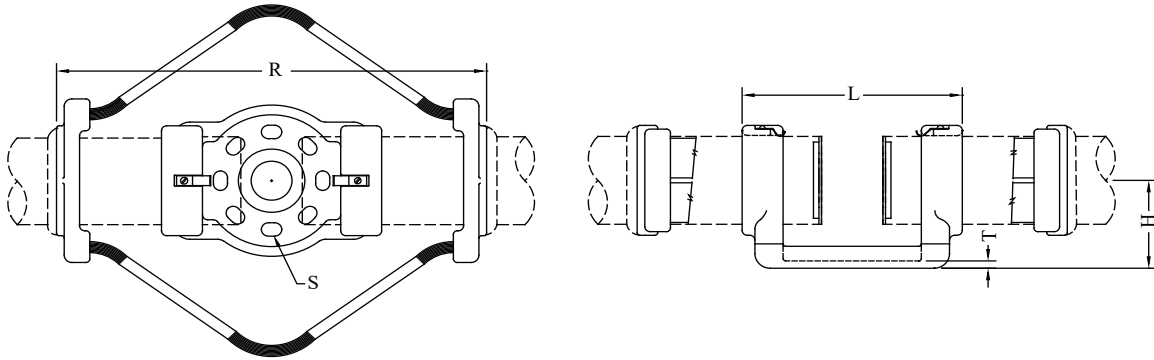

CATALOG NUMBER	PIPE SIZE (NPS)	BOLT CIRCLE	DIMENSIONS - INCHES					WEIGHT (POUNDS)
			H	L	R	S	T	
WXCTO-53-3	1-1/2	3	2-1/2	7-1/8	13-1/2	9/16 x 13/16	1/2	6.95
WXCTO-53-5		5	2-1/2	9-1/4	15-1/2	11/16 x 15/16	1/2	7.70
WXCTO-58-3	2	3	2-3/4	7-1/4	16-1/4	9/16 x 1-1/16	1/2	8.80
WXCTO-58-5		5	2-3/4	9-1/8	16-1/4	11/16 x 15/16	1/2	9.30
WXCTO-60-3	2-1/2	3	3-1/8	7-1/4	16-3/4	9/16 x 13/16	1/2	12.60
WXCTO-60-5		5	3-1/8	9-1/4	18-1/4	11/16 x 15/16	1/2	14.30
WXCTO-62-3	3	3	3-5/8	7-1/4	17	9/16 x 13/16	1/2	12.60
WXCTO-62-5		5	3-5/8	9-1/4	18-1/4	11/16 x 15/16	1/2	14.30
WXCTO-62-7		7	3-5/8	12-1/2	20-1/4	13/16 x 1	1/2	16.05
WXCTO-63-3	3-1/2	3	4	7-1/4	15-1/4	9/16 x 13/16	1/2	14.85
WXCTO-63-5		5	4	9-1/4	20-1/4	11/16 x 15/16	1/2	17.55
WXCTO-63-7		7	4	12-1/2	22-1/4	13/16 x 1-5/16	1/2	21.15
WXCTO-64-3	4	3	4-1/2	7-1/8	20	9/16 x 13/16	1/2	20.85
WXCTO-64-5		5	4-1/2	10-3/4	21	11/16 x 1	3/8	25.20
WXCTO-64-7		7	4-1/2	12-1/2	22-1/4	13/16 x 1-5/16	1/2	27.00
WXCTO-67-3	5	3	5	7-7/16	15-7/16	9/16 x 13/16	1/2	27.95
WXCTO-67-5		5	5	13-3/4	26-3/4	11/16 x 1-1/16	7/16	43.45
WXCTO-67-7		7	5	13-1/2	26-7/8	13/16 x 1-5/16	1/2	43.30
WXCTO-69-3	6	3	5-1/2	13	25-1/4	9/16 x 13/16	3/8	58.30
WXCTO-69-5		5	5-1/2	14	27	11/16 x 1-1/16	3/8	56.65
WXCTO-69-7		7	5-1/2	13-1/2	27	13/16 x 1-3/16	1/2	58.10

BRONZE BUS SUPPORTS



ASTI-BR

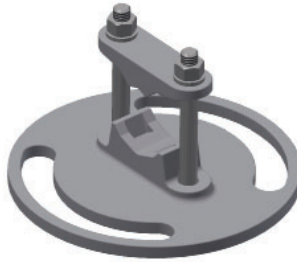

CJ



CCTI



CN



CXTI



SCRI



SCRI 2



SCTI



SVTI

BRONZE BUS SUPPORTS

TYPE ASTI-BR

Horizontal Bolted
Pipe to Insulator

Bronze alloy support for copper pipe.
Slip or rigid fit is provided by rotating cap members.
Each cap member is provided with a static spring.

Casting Alloy: Electrical Bronze
Clamping Hardware: Silicon Bronze
Mounting Hardware: Galvanized Steel

Hardware supplied for CAP mounting.
For PIN mounting, add suffix (P) to catalog number.
Example: ASTI-63-3P-BR

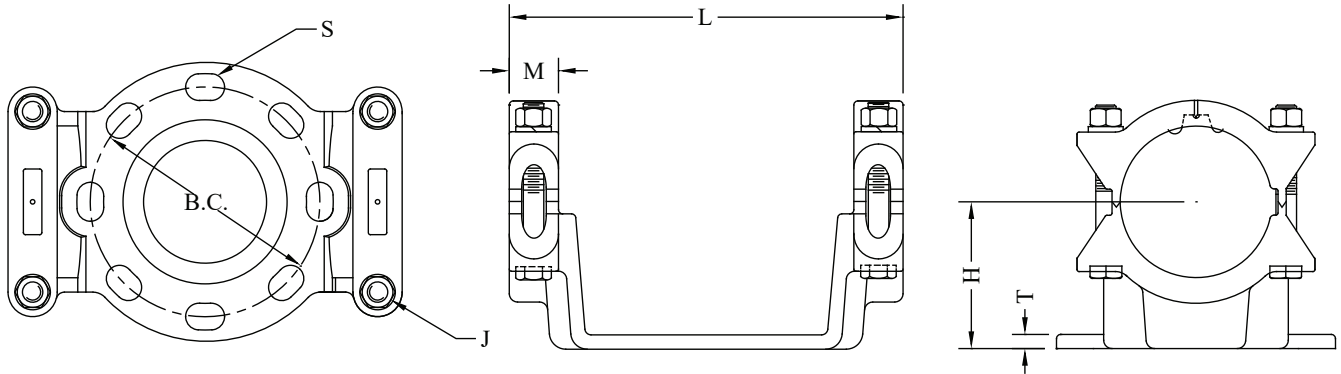

CATALOG NUMBER	PIPE SIZE (NPS)	BOLT CIRCLE	DIMENSIONS - INCHES						WEIGHT (POUNDS)
			H	L	M	S	J	T	
ASTI-30-3-BR	3/4	3	2	8	1-1/2	9/16 x 13/16	1/2	5/16	5.60
ASTI-30-5-BR		CONTACT FACTORY FOR DETAILS							
ASTI-39-3-BR	1	3	2	7-1/2	1-1/8	9/16 x 13/16	1/2	5/16	6.20
ASTI-39-5-BR		5	2-1/4	9-3/4	1-1/8	11/16 x 1-1/16	1/2	5/16	7.35
ASTI-49-3-BR	1-1/4	3	2-1/4	7-1/8	1-3/8	9/16 x 13/16	1/2	3/8	8.70
ASTI-49-5-BR		5	2-1/4	9-1/2	1-3/8	11/16 x 1-1/8	1/2	3/8	10.70
ASTI-53-3-BR	1-1/2	3	2-1/2	7-1/8	1-3/8	9/16 x 13/16	1/2	3/8	7.05
ASTI-53-5-BR		5	2-1/2	9-5/8	1-3/8	11/16 x 1-1/16	1/2	3/8	9.10
ASTI-58-3-BR	2	3	2-3/4	7-3/8	1-1/2	9/16 x 13/16	1/2	3/8	8.80
ASTI-58-5-BR		5	2-3/4	9-7/8	1-1/2	11/16 x 1-1/16	1/2	3/8	9.95
ASTI-60-3-BR	2-1/2	3	3-1/8	7-1/2	1-1/2	9/16 x 13/16	1/2	3/8	11.35
ASTI-60-5-BR		5	3-1/8	9-5/8	1-1/2	11/16 x 15/16	1/2	7/16	12.50
ASTI-62-3-BR	3	3	3-5/8	8-1/2	1-1/2	9/16 x 13/16	5/8	1/2	19.15
ASTI-62-5-BR		5	3-5/8	9-3/4	1-1/2	11/16 x 15/16	5/8	1/2	20.95
ASTI-63-3-BR	3-1/2	3	4	8-1/4	1-1/2	9/16 x 13/16	5/8	1/2	20.20
ASTI-63-5-BR		5	4	9-3/4	1-1/2	11/16 x 1-1/16	5/8	1/2	21.95
ASTI-64-3-BR	4	3	4-1/2	8-1/2	1-1/2	9/16 x 13/16	5/8	3/8	20.85
ASTI-64-5-BR		5	4-1/2	10	1-1/2	11/16 x 1-1/16	5/8	7/16	23.70

BRONZE BUS SUPPORTS

TYPE CCTI

Horizontal Bolted (Coupler)
Pipe to Insulator

Bronze alloy rigid bus support coupler for copper pipe.

Hardware supplied for CAP mounting.

For PIN mounting, add suffix (P) to catalog number.

Example: CCTI-49-5P

Casting Alloy: Electrical Bronze

Clamping Hardware: Silicon Bronze

Mounting Hardware: Galvanized Steel

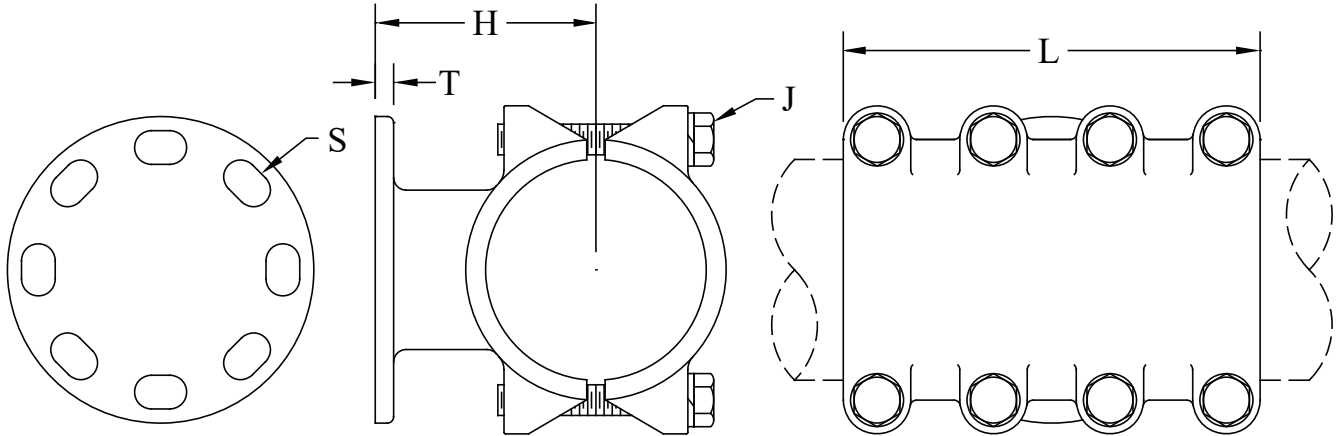

CATALOG NUMBER	PIPE SIZE (NPS)	BOLT CIRCLE	DIMENSIONS - INCHES					WEIGHT (POUNDS)
			H	L	J	S	T	
CCTI-21-3	1/2	3	1-3/4	4-1/4	3/8	9/16 x 13/16	9/32	2.75
CCTI-21-5		5	2-1/8	4-1/4	3/8	11/16 x 1-1/16	9/32	3.20
CCTI-30-3	3/4	3	2	4-1/4	3/8	9/16 x 13/16	9/32	3.70
CCTI-30-5		5	2-1/4	4-1/4	3/8	11/16 x 1-1/16	9/32	4.35
CCTI-39-3	1	3	2	5	3/8	9/16 x 13/16	5/16	6.55
CCTI-39-5		5	2	5	3/8	11/16 x 1-1/16	3/8	8.20
CCTI-49-3	1-1/4	3	2-1/4	5-5/8	1/2	9/16 x 13/16	1/4	7.00
CCTI-49-5		5	2-1/4	5-3/4	1/2	11/16 x 1-1/16	5/16	7.75
CCTI-53-3	1-1/2	3	2-1/2	5-3/4	1/2	9/16 x 1-1/16	9/32	8.75
CCTI-53-5		5	2-1/2	6-1/4	1/2	11/16 x 1-1/16	5/16	13.55
CCTI-58-3	2	3	2-3/4	5-5/8	1/2	9/16 x 13/16	9/32	10.55
CCTI-58-5		5	2-3/4	5-5/8	1/2	11/16 x 1-1/16	9/32	12.45
CCTI-60-3	2-1/2	3	3-1/8	5-5/8	1/2	11/16 x 13/16	5/16	14.25
CCTI-60-5		5	3-3/16	6-1/16	1/2	11/16 x 1-1/16	5/16	15.95
CCTI-62-3	3	3	3-5/8	7-3/8	5/8	9/16 x 13/16	5/16	20.35
CCTI-62-5		5	3-5/8	7-3/8	5/8	11/16 x 1-1/16	5/16	22.25
CCTI-63-3	3-1/2	3	4	7-3/4	5/8	9/16 x 13/16	5/16	22.95
CCTI-63-5		5	4	7-3/4	5/8	11/16 x 1-1/16	5/16	24.20
CCTI-64-3	4	3	4-1/2	8	5/8	9/16 x 13/16	5/16	25.85
CCTI-64-5		5	4-1/2	8-1/2	5/8	11/16 x 1-1/16	3/8	31.65

BRONZE BUS SUPPORTS

TYPE CJ

Horizontal Bolted
Cable to Insulator

Bronze alloy bus support for copper cable or pipe in rigid position.
Hardware supplied for CAP mounting.
For PIN mounting, add suffix (P) to catalog number.
Example: CJ-3P

Casting Alloy: Electrical Bronze
Clamping Hardware: Silicon Bronze
Mounting Hardware: Galvanized Steel

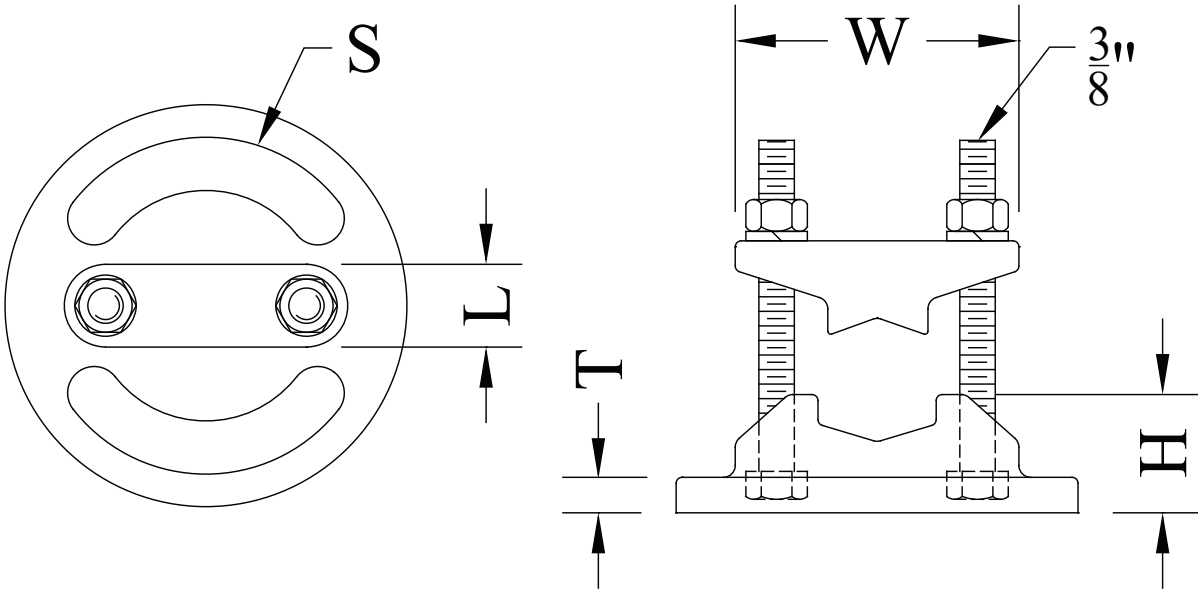

CATALOG NUMBER	CONDUCTOR RANGE	BOLT CIRCLE	DIMENSIONS - INCHES					WEIGHT (POUNDS)
			H	L	W	S	T	
*CJ-3	#2 - 2000 MCM	3	1-1/4	1	3-1/4	9/16 SLOTS	9/32	2.10
*CJ-5	#2 - 2000 MCM	5	1-1/4	1	3-1/4	11/16 SLOTS	5/16	2.80

*Either size will also accommodate a range of pipe from 1/2" O.D. - 1-3/4" O.D. or 1/4" NPS. - 1-1/4" NPS.
Also order Type CJP-3-12 or CJP-5-12 - Same basic design with 1/2" hardware for 1-1/2"-2" NPS.
Consult manufacturer for further details or unlisted applications.

BRONZE BUS SUPPORTS

TYPE CN

Horizontal
Pipe to Insulator

Bronze alloy, slip-fit bus support for copper pipe.
Adjustable base slots allow rotation up to 90° for alignment.
Hardware supplied for CAP mounting.

For PIN mounting, add suffix (P) to catalog number.

Casting Alloy: Eletrical Bronze

Mounting Hardware: Galvanized Steel

Example: CN-26-3P

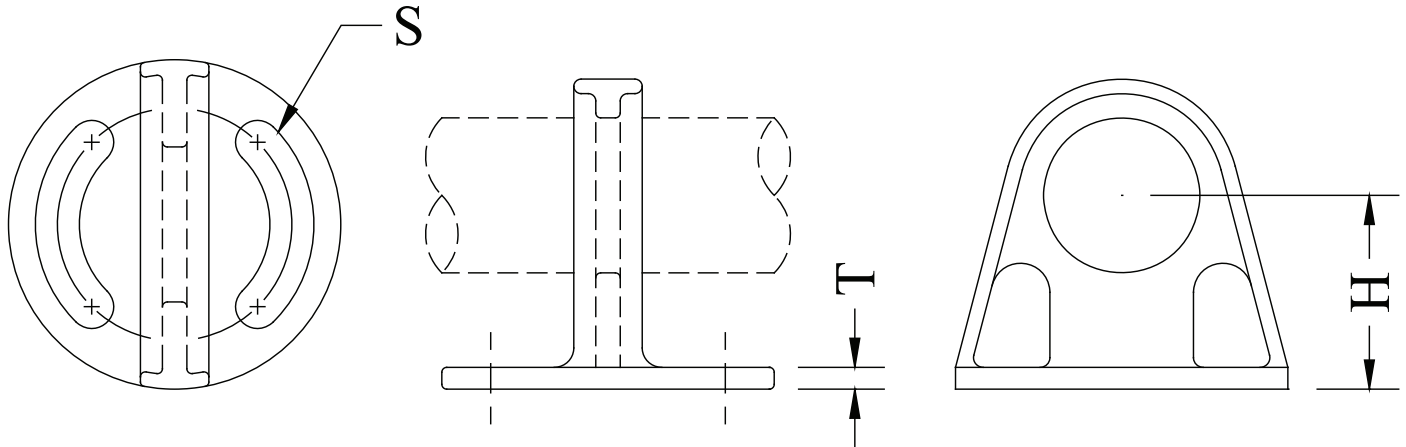

CATALOG NUMBER	PIPE SIZE (NPS)	BOLT CIRCLE	DIMENSIONS - INCHES			WEIGHT (POUNDS)
			H	S (SLOTS)	T	
CN-22-3	1/2	3	1-3/4	9/16	3/8	2.00
CN-23-3	3/4	3	2	9/16	9/32	2.25
CN-24-3	1	3	2	9/16	1/4	2.50
CN-25-3	1-1/4	3	2-1/4	9/16	1/4	2.75
CN-26-3	1-1/2	3	2-1/2	9/16	9/32	3.00
CN-26-5		5	2-1/2	11/16	3/8	4.00
CN-27-3	2	3	2-3/4	9/16	9/32	3.50
CN-27-5		5	2-3/4	11/16	3/8	4.50
CN-28-3	2-1/2	3	3-1/8	9/16	9/32	4.00
CN-28-5		5	3-1/8	11/16	3/8	5.00
CN-29-3	3	3	3-5/8	9/16	9/32	4.50
CN-29-5		5	3-5/8	11/16	3/8	5.50
CN-31-3	4	3	4-1/4	9/16	3/8	5.00
CN-31-5		5	4-1/2	11/16	3/8	6.00
CN-33-3	5	3	4-1/4	9/16	3/8	5.50
CN-33-5		5	5-1/4	11/16	3/8	6.50
CN-34-5	6	5	5	11/16	3/8	7.00

BRONZE BUS SUPPORTS

TYPE CXTI

Expansion
Pipe to Insulator

Bronze alloy expansion bus support for copper pipe.
Hardware supplied for CAP mounting.

For PIN mounting add suffix (P) to catalog number.
Example: CXTI-53-5P

Casting Alloy: Electrical Bronze
Flexible Straps: Laminated Copper
Clamping Hardware: Silicon Bronze
Mounting Hardware: Galvanized Steel

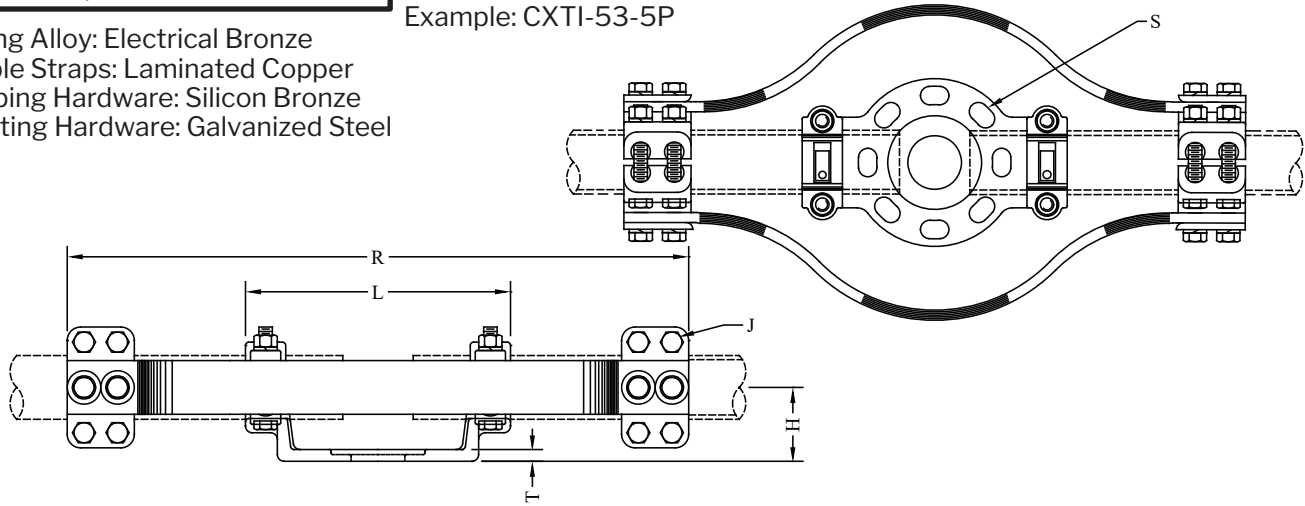

CATALOG NUMBER	PIPE SIZE (NPS)	BOLT CIRCLE	DIMENSIONS - INCHES						WEIGHT (POUNDS)
			H	L	R	J	S	T	
CXTI-21-3	1/2	3	1-11/16	2-1/2	15	3/8	9/16 x 13/16	5/16	12.70
CXTI-21-5		5	1-3/4	2-1/4	15-1/2	3/8	11/16 x 1-1/16	5/16	13.75
CXTI-30-3	3/4	3	2	8	16	3/8	9/16 x 13/16	5/16	13.45
CXTI-30-5		5	2	4-1/2	15-1/2	3/8	11/16 x 1-1/16	3/8	14.90
CXTI-39-3	1	3	2	5-3/4	13-3/4	3/8	9/16 x 13/16	5/16	14.75
CXTI-39-5		5	2	5-3/4	15-5/8	1/2	11/16 x 1-1/16	5/16	17.15
CXTI-49-3	1-1/4	3	2-1/4	4-3/4	14	1/2	9/16 x 13/16	9/32	27.35
CXTI-49-5		5	2-3/8	7-3/4	17-1/4	1/2	11/16 x 15/16	9/32	30.20
CXTI-53-3	1-1/2	3	2-1/2	4-3/4	15	1/2	9/16 x 13/16	9/32	24.30
CXTI-53-5		5	2-1/2	6-1/4	15-5/8	1/2	11/16 x 1-1/16	5/16	29.65
CXTI-58-3	2	3	2-3/4	7-5/8	20-1/2	1/2	9/16 x 13/16	3/8	36.75
CXTI-58-5		5	2-3/4	9-7/8	23	1/2	11/16 x 1-1/16	3/8	38.90
CXTI-60-3	2-1/2	3	3-1/8	7-1/2	20-1/2	1/2	9/16 x 13/16	3/8	47.85
CXTI-60-5		5	3-1/8	9-3/4	22-5/8	1/2	11/16 x 15/16	7/16	49.75
CXTI-62-3	3	3	3-5/8	8-1/2	21-3/4	5/8	9/16 x 13/16	1/2	63.80
CXTI-62-5		5	3-11/16	9-3/4	21-3/4	5/8	11/16 x 15/16	1/2	65.60
CXTI-63-3	3-1/2	3	4	7-3/4	19-1/2	5/8	9/16 x 1-3/16	1/2	74.65
CXTI-63-5		5	4	9-1/4	19-1/2	5/8	11/16 x 1	1/2	78.40
CXTI-64-3	4	3	4-1/2	7-1/4	25-1/4	5/8	9/16 x 13/16	1/2	82.60
CXTI-64-5		5	4-1/2	9-1/4	25-1/4	5/8	11/16 x 1	1/2	84.10

BRONZE BUS SUPPORTS

TYPE SCRI

Horizontal Bolted
Cable to Insulator

Bronze alloy bus support for copper cable.
Hardware supplied for CAP mounting.

For PIN mounting, add suffix (P) to catalog number.

Casting Alloy: Electrical Bronze
Clamping Hardware: Silicon Bronze
Mounting Hardware: Galvanized Steel

Example: SCRI-20-5P

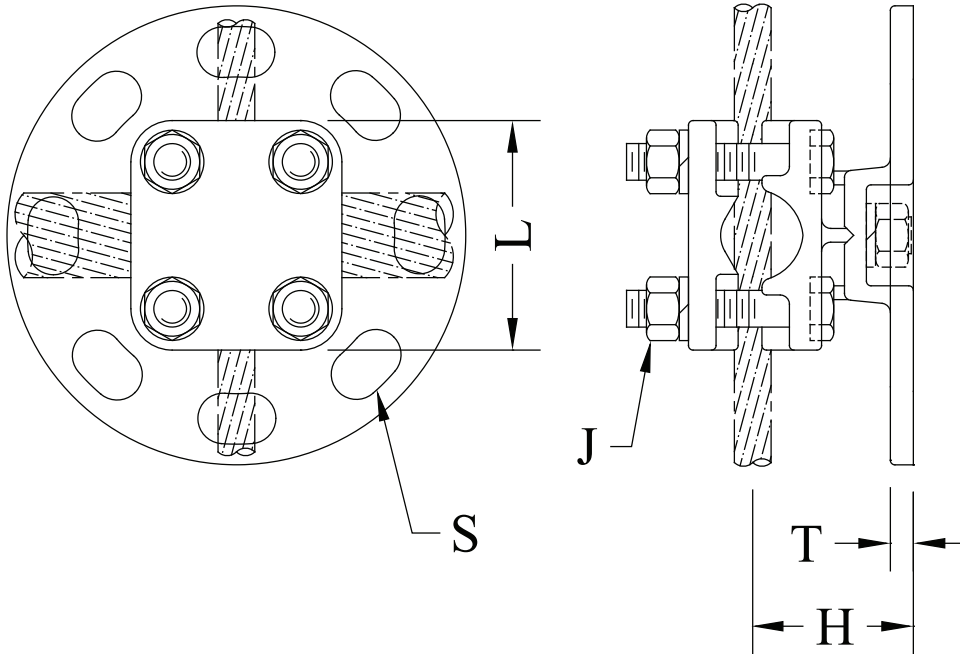

CATALOG NUMBER	CONDUCTOR RANGE	BOLT CIRCLE	DIMENSIONS - INCHES					WEIGHT (POUNDS)
			H	L	J	S	T	
SCRI-20-3	#6W - 750 MCM	3	2	2-1/2	3/8	9/16 x 13/16	5/16	4.00
SCRI-20-5		5	2	2-1/2	3/8	11/16 x 1-1/16	3/8	5.25
SCRI-34-3	4/0W - 1000 MCM	3	2-1/8	3-1/8	1/2	9/16 x 13/16	5/16	5.00
SCRI-34-5		5	2-1/8	3-1/8	1/2	11/16 x 1-1/16	5/16	6.25
SCRI-48-3	750 - 2000 MCM	3	2-1/2	3-1/2	1/2	9/16 x 13/16	5/16	5.50
SCRI-48-5		5	2-1/2	3-1/2	1/2	11/16 x 1-1/16	5/16	6.75

BRONZE BUS SUPPORTS

TYPE SCRI2

Horizontal Bolted
Two Cables to Insulator

Bronze alloy bus support for two copper cables.
Hardware supplied for CAP mounting.

For PIN mounting, add suffix (P) to catalog number

Casting Alloy: Electrical Bronze

Clamping Hardware: Silicon Bronze

Mounting Hardware: Galvanized Steel

Example: SCRI2-34-3P

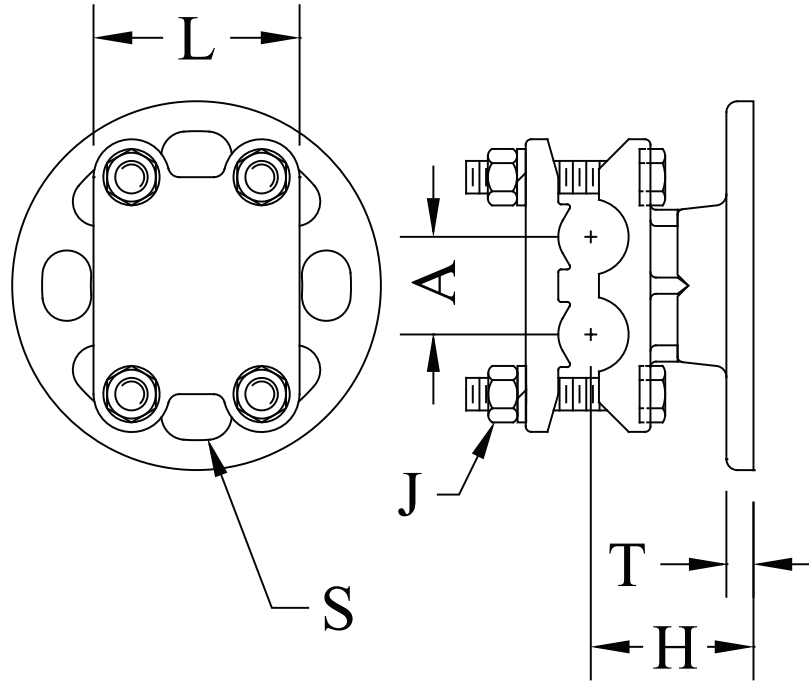

CATALOG NUMBER	CONDUCTOR RANGE	BOLT CIRCLE	DIMENSIONS - INCHES						WEIGHT (POUNDS)
			H	L	A	J	S	T	
SCRI2-20-3	4/0 - 500 MCM	3	2	2-3/8	1-1/8	3/8	9/16 x 13/16	5/16	6.00
SCRI2-20-5		5	1-7/8	2-3/8	1-1/8	3/8	11/16 x 1-1/16	5/16	7.25
SCRI2-34-3	4/0 - 1000 MCM	3	2-5/8	3-1/8	1-5/8	1/2	9/16 x 1-1/16	5/16	7.00
SCRI2-34-5		5	2-5/8	3-1/8	1-5/8	1/2	11/16 x 1-1/16	5/16	8.25
SCRI2-48-3	1500 - 2000 MCM	3	2-1/2	3-1/4	1-7/8	1/2	9/16 x 13/16	5/16	10.50
SCRI2-48-5		5	2-1/2	3-1/4	1-7/8	1/2	11/16 x 1-1/16	5/16	11.00

BRONZE BUS SUPPORTS

TYPE SCTI

Horizontal Bolted
Pipe to Insulator

Bronze alloy bus support for copper pipe.
Slip or rigid fit is provided by rotating cap.
Cap is provided with a static spring.

Casting Alloy: Electrical Bronze
Clamping Hardware: Silicon Bronze
Mounting Hardware: Galvanized Steel

Hardware supplied for CAP mounting.
For PIN mounting, add suffix (P) to catalog number.
Example: SCTI-58-3P

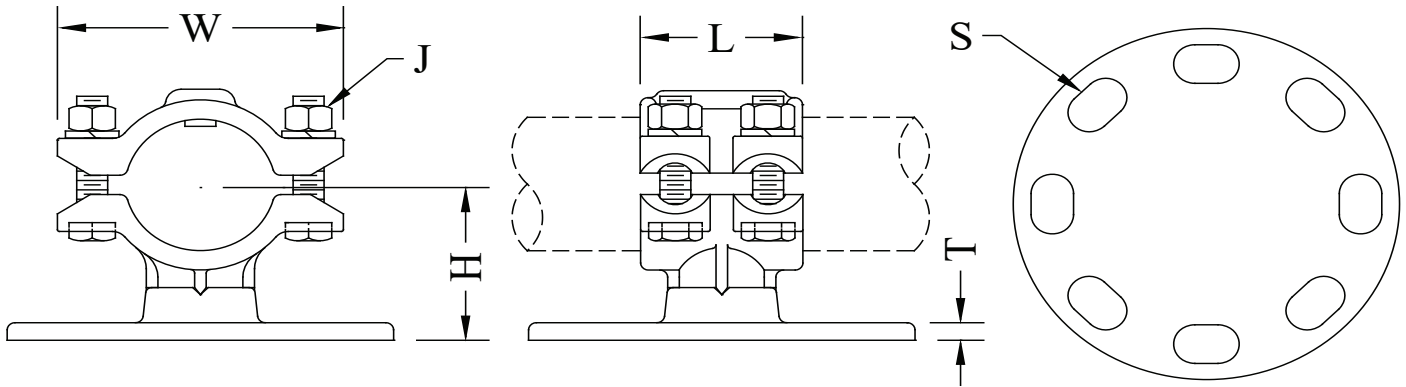

CATALOG NUMBER	PIPE SIZE (NPS)	BOLT CIRCLE	DIMENSIONS - INCHES						WEIGHT (POUNDS)
			H	L	W	J	S	T	
SCTI-21-3	1/2	3	1-3/4	2-1/4	2-3/4	3/8	9/16 x 13/16	5/16	4.05
SCTI-21-5		5	1-3/4	2-1/4	2-3/4	3/8	11/16 x 1	5/16	5.75
SCTI-30-3	3/4	3	2	2-1/4	2-3/4	3/8	9/16 x 13/16	5/16	4.15
SCTI-30-5		5	2	2-1/4	2-3/4	3/8	11/16 x 1	5/16	5.80
SCTI-39-3	1	3	2	2-1/4	2-3/4	3/8	9/16 x 13/16	5/16	4.15
SCTI-39-5		5	2-1/16	2-1/4	2-3/4	3/8	11/16 x 1-1/16	5/16	5.80
SCTI-49-3	1-1/4	3	2-1/4	2-5/8	3-9/16	1/2	9/16 x 13/16	5/16	4.85
SCTI-49-5		5	2-1/4	2-5/8	3-9/16	1/2	11/16 x 1-1/16	5/16	6.50
SCTI-53-3	1-1/2	3	2-1/2	2-5/8	3-3/4	1/2	9/16 x 13/16	5/16	6.75
SCTI-53-5		5	2-1/2	2-5/8	3-3/4	1/2	11/16 x 1	5/16	8.35
SCTI-58-3	2	3	2-3/4	2-5/8	4-5/8	1/2	9/16 x 13/16	5/16	5.90
SCTI-58-5		5	2-3/4	2-5/8	4-5/8	1/2	11/16 x 1-1/16	5/16	7.60
SCTI-60-3	2-1/2	3	3-1/8	2-5/8	4-5/8	1/2	9/16 x 13/16	5/16	6.35
SCTI-60-5		5	3-1/8	2-5/8	4-5/8	1/2	11/16 x 1-1/16	5/16	8.00
SCTI-62-3	3	3	3-5/8	2-7/8	5-3/4	5/8	9/16 x 13/16	5/16	10.15
SCTI-62-5		5	3-5/8	2-7/8	5-3/4	5/8	11/16 x 1-1/16	5/16	11.85
SCTI-63-3	3-1/2	3	4	3	6-1/4	5/8	9/16 x 13/16	5/16	11.35
SCTI-63-5		5	4	3	6-1/4	5/8	11/16 x 1-1/16	5/16	13.00
SCTI-64-3	4	3	4-1/2	8-1/2	6-7/8	5/8	9/16 x 13/16	3/8	20.80
SCTI-64-5		5	4-1/2	10	7	5/8	11/16 x 1-1/16	7/16	23.70

BRONZE BUS SUPPORTS

TYPE SVTI

Vertical Bolted
Pipe to Insulator

Bronze alloy bus support for vertical dead-ending copper pipe.
Clamping bolts have hex-stops for one-wrench installation.
Hardware supplied for CAP mounting.

Casting Alloy: Electrical Bronze
Clamping Hardware: Silicon Bronze
Mounting Hardware: Galvanized Steel

For PIN mounting, add suffix (P) to catalog number.
Example: SVTI-63-3P

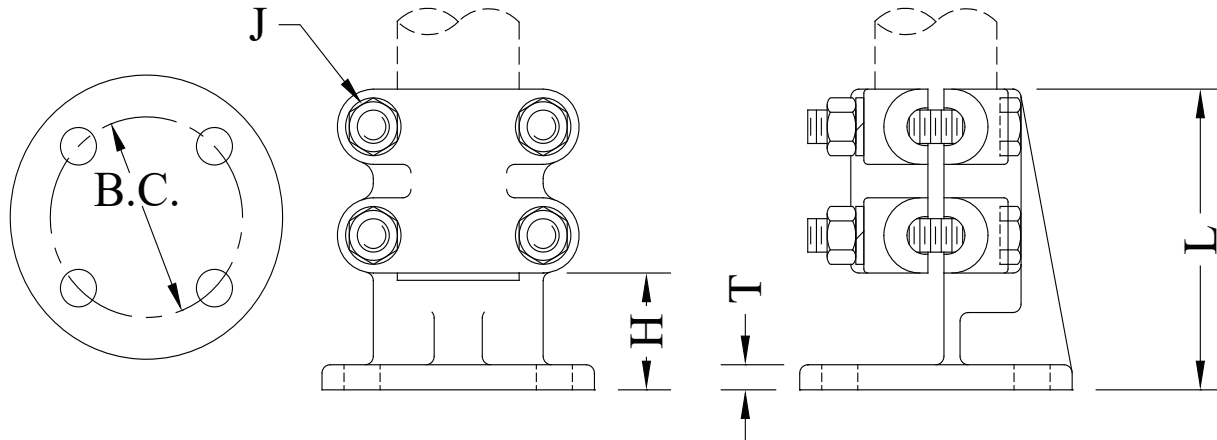

CATALOG NUMBER	PIPE SIZE (NPS)	BOLT CIRCLE	DIMENSIONS - INCHES				WEIGHT (POUNDS)
			H	L	J	T	
SVTI-21-3	1/2	3	2-1/8	4-1/8	3/8	5/16	3.25
SVTI-21-5		5	1-3/4	2-1/4	3/8	3/8	3.75
SVTI-30-3	3/4	3	1-1/8	3-1/8	3/8	5/16	4.00
SVTI-30-5		CONTACT FACTORY FOR DETAILS					
SVTI-39-3	1	3	1	3-1/2	3/8	5/16	5.50
SVTI-39-5		CONTACT FACTORY FOR DETAILS					
SVTI-49-3	1-1/4	3	1-7/8	4-5/8	1/2	3/8	6.45
SVTI-49-5		CONTACT FACTORY FOR DETAILS					
SVTI-53-3	1-1/2	3	1-3/4	4-1/2	1/2	3/8	6.55
SVTI-53-5		5	1-3/4	4-1/2	1/2	5/8	8.30
SVTI-58-3	2	3	1-11/16	4-11/16	1/2	9/32	7.90
SVTI-58-5		5	1-1/2	4-1/2	1/2	5/16	9.65
SVTI-60-3	2-1/2	3	1-7/8	4-7/8	1/2	5/16	10.45
SVTI-60-5		5	2-3/8	6-7/8	1/2	7/16	14.00
SVTI-62-3	3	3	2	5-1/4	5/8	9/32	13.40
SVTI-62-5		CONTACT FACTORY FOR DETAILS					
SVTI-63-3	3-1/2	3	2	5-1/4	5/8	5/16	12.25
SVTI-63-5		5	2	5-1/4	5/8	5/16	15.95
SVTI-64-3	4	3	2	5-1/4	5/8	5/16	17.55
SVTI-64-5		5	2	5-1/4	5/8	5/16	20.20

EHV BUS SUPPORTS

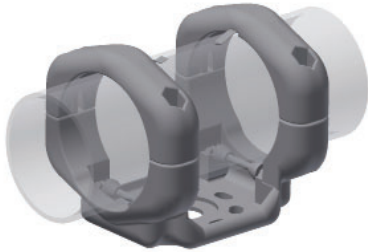

ARTIHV



ASCA3

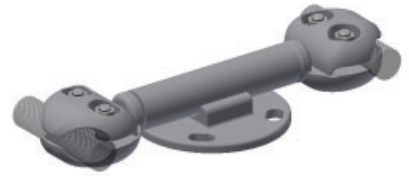

ASCAHV

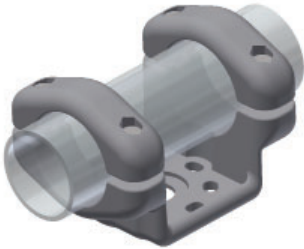

ASTIHV



ASWH-EHV



AVCAD

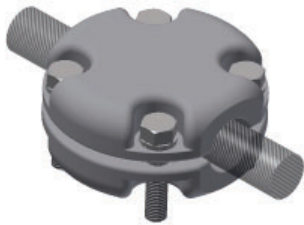

AVCA-HV



AVCHV



WCTI-EHV



WRTIHV



WSTIHV



WVTI-CS



WVTSI-CS



WXCCI



WXCTO-CS

EHV BUS SUPPORTS

TYPE ARTIHV

Horizontal Bolted Roller Support
Pipe to Insulator

Type ARTIHV is designed for low-friction slide operation at voltages through 500kV. Tapered rollers provide four-point support for the tubular bus. This style is especially recommended for applications where the supported bus weight exceeds 400 pounds.

Casting Alloy: 356-T6 Aluminum
Clamping Hardware: Aluminum Alloy
Mounting Hardware: Galvanized Steel

ALUMINUM • 345 - 500kV

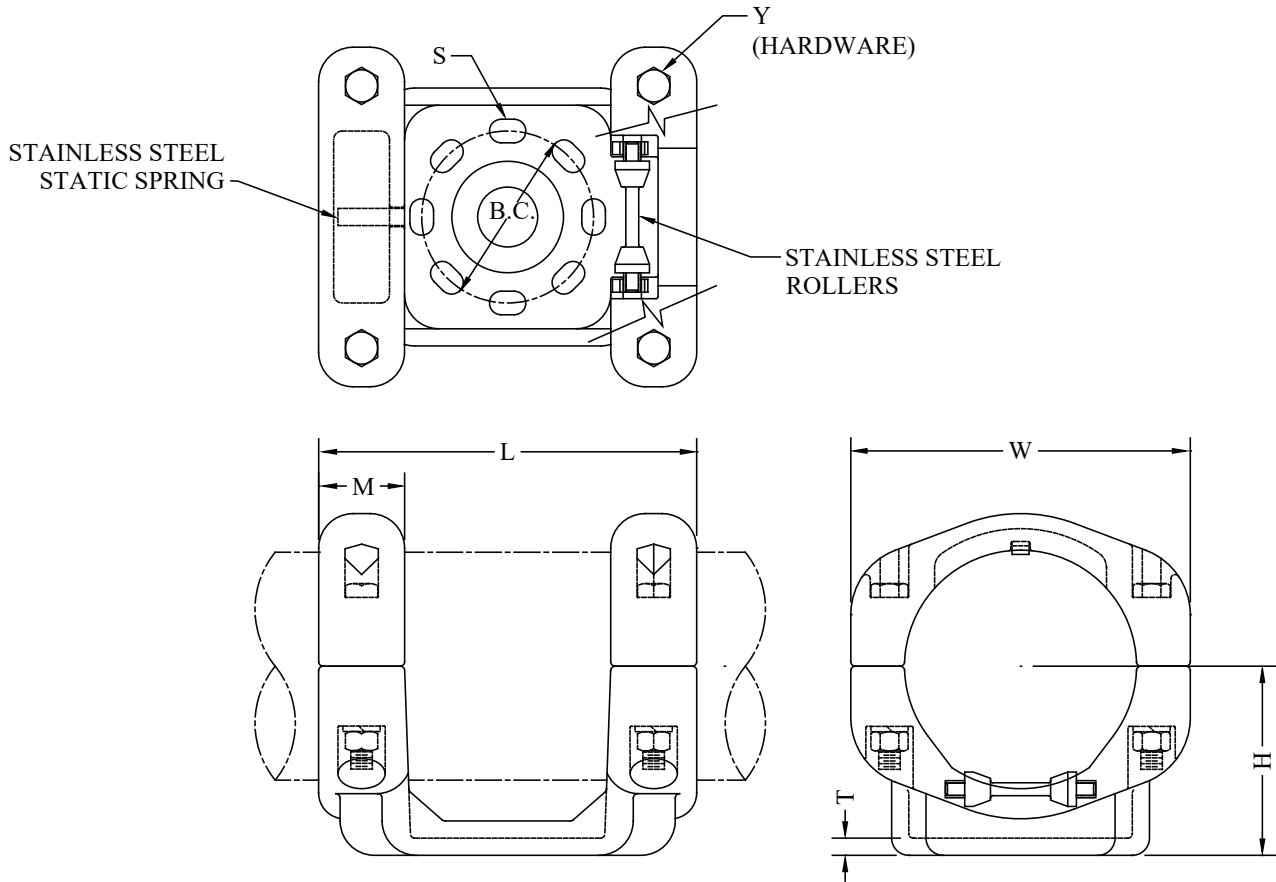

CATALOG NUMBER	PIPE SIZE (NPS)	BC	DIMENSIONS - INCHES							WEIGHT (POUNDS)
			H	L	M	S	W	Y	T	
ARTIHV-67-5	5	5	5	12	2-1/2	11/16 x 1-1/16	9	5/8	1/2	17.45
ARTIHV-67-7		7	5	14-1/4	2-1/2	13/16 x 1-3/16	9	5/8	1/2	17.80
ARTIHV-69-5	6	5	5-1/2	11	2-1/2	11/16 x 1-1/16	9-7/8	5/8	1/2	20.95
ARTIHV-69-7		7	5-1/2	14-1/4	2-1/2	13/16 x 1-3/8	9-7/8	5/8	1/2	21.25
ARTIHV-70-5	8 O.D.	5	6-1/2	12	3	11/16 x 1-1/16	12-1/2	3/4	1/2	39.65
ARTIHV-70-7		7	6-1/2	16	3	13/16 x 1-1/4	12-1/2	3/4	1/2	43.00
ARTIHV-71-5	8	5	7	16	3	11/16 x 1-1/16	12-1/2	3/4	3/4	30.00
ARTIHV-71-7		7	7	16	3	13/16 x 1-1/4	12-1/2	3/4	3/4	33.90

EHV BUS SUPPORTS

TYPE ASCA3

Bolted

Three Cable to Insulator

Casting Alloy: 356-T6 Aluminum
 Tubular Arms: 6061-T6 Aluminum
 Clamping Hardware: Aluminum Alloy
 Mounting Hardware: Galvanized Steel

ALUMINUM • 345 - 500kV

Type ASCA3 is designed for corona-free service through 500kV. Independent sub conductor clamping on tubular support arms increases shock-absorbing capabilities under severe vibration conditions. Sub conductor spacing other than the 18-inches shown is available when specified.

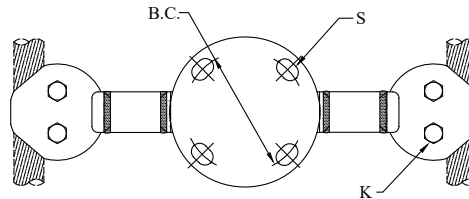
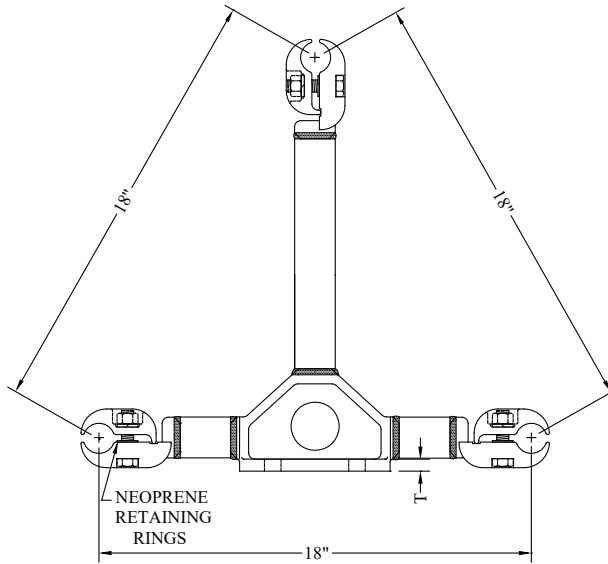

NORMALLY SUPPLIED WITH
 HARDWARE
 FOR CAP MOUNTING

CATALOG NUMBER	CONDUCTOR RANGE		BOLT CIRCLE	DIMENSIONS - INCHES				WEIGHT (POUNDS)
	AAC	ACSR		A	K	S	T	
ASCA3-35-5	954 - 1113	795 - 954	5	4	1/2	11/16 x 1	1/2	6.75
ASCA3-38-5	1113 - 1192	1033 - 1113	5	4	1/2	11/16 x 1-1/16	1/2	7.00
ASCA3-41-5	1272 - 1431	1192 - 1272	5	4	1/2	11/16 x 1-1/16	1/2	7.25
ASCA3-41-7	1272 - 1431	1192 - 1272	7	4	1/2	13/16 x 1-1/4	1/2	7.75
ASCA3-43-5	1510 - 1600	1351 - 1431	5	4	1/2	11/16 x 1-1/16	1/2	7.50
ASCA3-43-7	1510 - 1600	1351 - 1431	7	4	1/2	13/16 x 1-1/4	1/2	8.00
ASCA3-46-5	1750	1510 - 1590	5	4	1/2	11/16 x 1	1/2	8.25
ASCA3-46-7	1750	1510 - 1590	7	4	1/2	13/16 x 1-1/4	1/2	8.75
ASCA3-48-5	1933 - 2031	1780	5	4	1/2	11/16 x 1	1/2	8.50
ASCA3-48-7	1933 - 2031	1780	7	4	1/2	13/16 x 1-1/4	1/2	9.00
ASCA3-51-5	2250 - 2500	2156 - 2167	5	4-3/8	5/8	11/16 x 1-1/16	1/2	8.75
ASCA3-51-7	2250 - 2500	2156 - 2167	7	4-3/8	5/8	13/16 x 1-1/4	1/2	9.25
ASCA3-54-5	2250 - 3000	2312	5	4-3/8	5/8	11/16 x 1	1/2	9.00
ASCA3-54-7	2250 - 3000	2312	7	4-3/8	5/8	13/16 x 1-1/4	1/2	9.50

EHV BUS SUPPORTS

TYPE ASCAHV

Bolted

Two Cable to Insulator

Type ASCAHV is designed for corona-free service at 345kV or 500kV within the limits of the bundled conductor.

Cable spacing other than the 18-inch shown is available when specified.

Casting Alloy: 356-T6 Aluminum
 Support Arm: 6061-T6 Aluminum
 Clamping Hardware: Aluminum Alloy
 Mounting Hardware: Galvanized Steel

ALUMINUM • 345 - 500kV

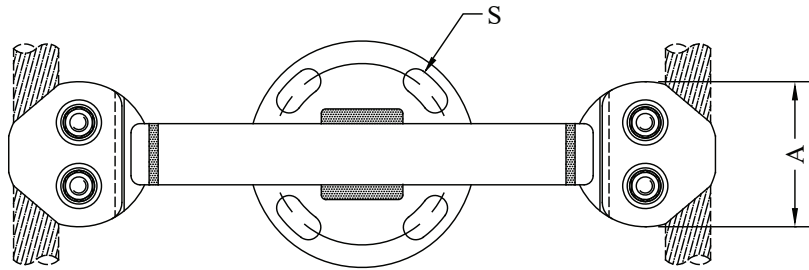

NORMALLY SUPPLIED WITH
 HARDWARE
 FOR CAP MOUNTING

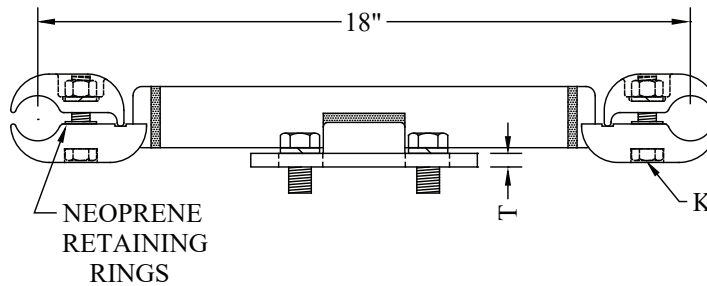

CATALOG NUMBER	CONDUCTOR RANGE		BOLT CIRCLE	DIMENSIONS - INCHES				WEIGHT (POUNDS)
	AAC	ACSR		A	K	S	T	
ASCAHV-32-5	795 - 900	715 - 795	5	4	1/2	11/16 x 1	1/2	5.50
ASCAHV-35-5	954 - 1033	795 - 954	5	4	1/2	11/16 x 1	1/2	5.50
ASCAHV-38-5	1113 - 1192	1033 - 1113	5	4	1/2	11/16 x 1	3/8	6.00
ASCAHV-41-5	1272 - 1431	1192 - 1272	5	4	1/2	11/16 x 1	3/8	6.25
ASCAHV-43-5	1510 - 1600	1351 - 1431	5	4	1/2	11/16 x 1	3/8	7.50
ASCAHV-46-5	1750	1510 - 1590	5	4	1/2	11/16 x 1	3/8	8.00
ASCAHV-46-7	1750	1510 - 1590	7	4	1/2	13/16 x 1-1/4	3/8	8.50
ASCAHV-48-5	2000	1780	5	4	1/2	11/16 x 1	3/8	8.25
ASCAHV-48-7	2000	1780	7	4	1/2	13/16 x 1-1/4	3/8	8.75
ASCAHV-51-5	2250 - 2500	2032 - 2167	5	4-3/8	5/8	11/16 x 1	3/8	8.50
ASCAHV-51-7	2250 - 2500	2032 - 2167	7	4-3/8	5/8	13/16 x 1-1/4	3/8	9.00
ASCAHV-54-5	2250 - 3000	2312	5	4-3/4	5/8	11/16 x 1-1/16	3/8	9.50
ASCAHV-54-7	2250 - 3000	2312	7	4-3/4	5/8	13/16 x 1-1/4	3/8	9.50
ASCAHV-56-5	3000 - 3500	---	5	6-1/4	5/8	11/16 x 1	3/8	9.00
ASCAHV-56-7	3000 - 3500	---	7	6-1/4	5/8	13/16 x 1-1/4	3/8	9.75

EHV BUS SUPPORTS

TYPE ASTIHV

Horizontal Bolted Slide or Rigid
Pipe to Insulator

Type ASTIHV is designed for corona-free service, within the voltage limitations of the bus through 500kV. Slip or rigid fit is provided by rotating the cap members. Each cap member is provided with a static spring.

Casting Alloy: 356-T6 Aluminum
Clamping Hardware: Aluminum Alloy
Mounting Hardware: Galvanized Steel

ALUMINUM • 345 - 500kV

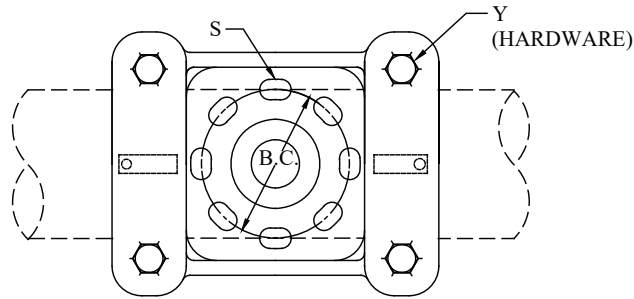

MOUNTING SLOTS
NORMALLY FURNISHED WITH HARDWARE
FOR CAP MOUNTING

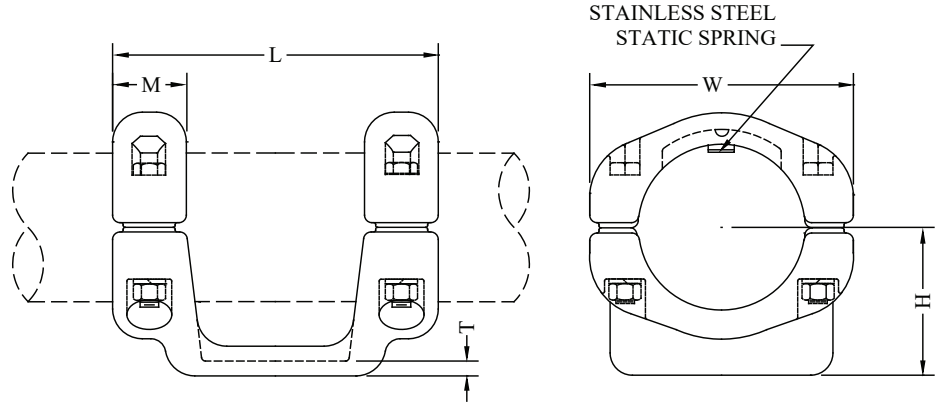

CATALOG NUMBER	PIPE SIZE (NPS)	BC	MAX KV	DIMENSIONS - INCHES							WEIGHT (POUNDS)
				H	L	M	S	W	Y	T	
ASTIHV-58-5	2	5	345	2-3/4	11	2-1/2	11/16 x 1	5-1/2	1/2	1/2	10.20
ASTIHV-58-7		7	345	2-3/4	13-1/2	2-1/2	13/16 x 1-3/16	5-1/2	1/2	1/2	11.80
ASTIHV-60-5	2-1/2	5	345	3-1/8	11	2-1/2	11/16 x 15/16	6-1/2	1/2	1/2	11.30
ASTIHV-60-7		7	345	3-1/8	13	2-1/2	13/16 x 1	6-1/2	1/2	1/2	12.50
ASTIHV-62-5	3	5	500	3-5/8	11	2-1/2	11/16 x 15/16	8	5/8	1/2	15.15
ASTIHV-62-7		7	500	3-5/8	13	2-1/2	13/16 x 1-3/16	8	5/8	1/2	16.50
ASTIHV-63-5	3-1/2	5	500	4	11	2-1/2	11/16 x 15/16	8	5/8	1/2	12.80
ASTIHV-63-7		7	500	4	13	2-1/2	13/16 x 1-3/16	8	5/8	1/2	16.60
ASTIHV-64-5	4	5	500	4-1/2	11	2-1/2	11/16 x 15/16	8-7/8	5/8	1/2	14.50
ASTIHV-64-7		7	500	4-1/2	13	2-1/2	13/16 x 1-3/16	8-1/2	5/8	1/2	15.30
ASTIHV-67-5	5	5	500	5	11	2-1/2	11/16 x 1-1/16	8-7/8	5/8	1/2	15.35
ASTIHV-67-7		7	500	5	13	2-1/2	13/16 x 1-3/16	8-7/8	5/8	1/2	19.05
ASTIHV-69-5	6	5	500	5-1/2	11	2-1/2	11/16 x 1	9-7/8	5/8	1/2	15.95
ASTIHV-69-7		7	500	5-1/2	14	2-1/2	13/16 x 1-1/8	9-7/8	5/8	1/2	22.00

EHV BUS SUPPORTS

TYPE ASTIHV-R

Horizontal Bolted Rotational Support
Pipe to Insulator

Type ASTIHV-R is designed for corona-free service, within the voltage limitations of the bus, through 500kV. The $\pm 15^\circ$ rotational feature greatly reduces torsional forces during fault conditions.

Slip or rigid fit is provided by rotating the cap members.

Each cap member is provided with a static spring.

Casting Alloy: 356-T6 Aluminum

Clamping Hardware: Aluminum Alloy

Mounting Hardware: Galvanized Steel

Other insulator mounting arrangements are available.

Consult manufacturer for further details or unlisted applications.

ALUMINUM • 345 - 500kV

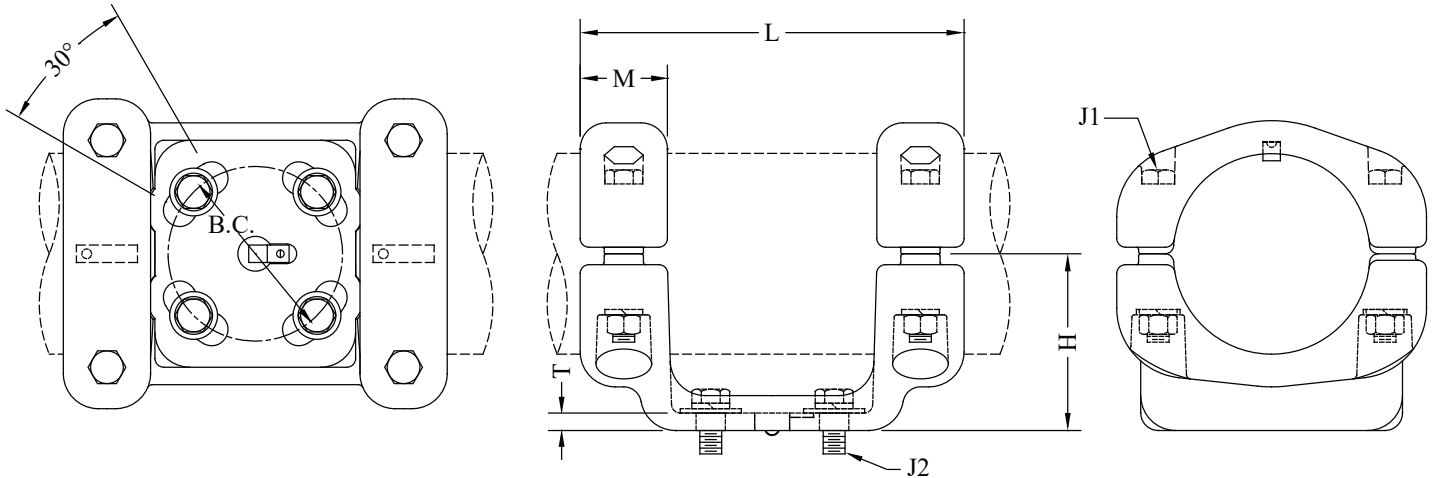

CATALOG NUMBER	PIPE SIZE (NPS)	BOLT CIRCLE	DIMENSIONS - INCHES						WEIGHT (POUNDS)
			H	L	M	J1	J2	T	
ASTIHV-R-64-5	4	5	4-1/2	11	2-1/2	5/8	5/8	1/2	14.90
ASTIHV-R-64-7		7	4-1/2	14	2-1/2	5/8	3/4	1/2	19.10
ASTIHV-R-67-5	5	5	5	11	2-1/2	5/8	5/8	1/2	15.65
ASTIHV-R-67-7		7	5	13	2-1/2	5/8	3/4	1/2	23.40
ASTIHV-R-69-5	6	5	5-1/2	11	2-1/2	5/8	5/8	1/2	19.80
ASTIHV-R-69-7		7	5-1/2	14	2-1/2	5/8	3/4	1/2	26.30

EHV BUS SUPPORTS

TYPE ASWH-EHV

Weldment - Slide or Rigid
Pipe to Insulator

Type ASWH-EHV hook-on bus supports are designed for corona-free service at voltage levels indicated in table below. Normally used for slip-fit, rigid fit is effected by welding each end as shown. All assemblies include static springs.

Casting Alloy: 356-T6 Aluminum
Mounting Hardware: Galvanized Steel

ALUMINUM • 345 - 500kV

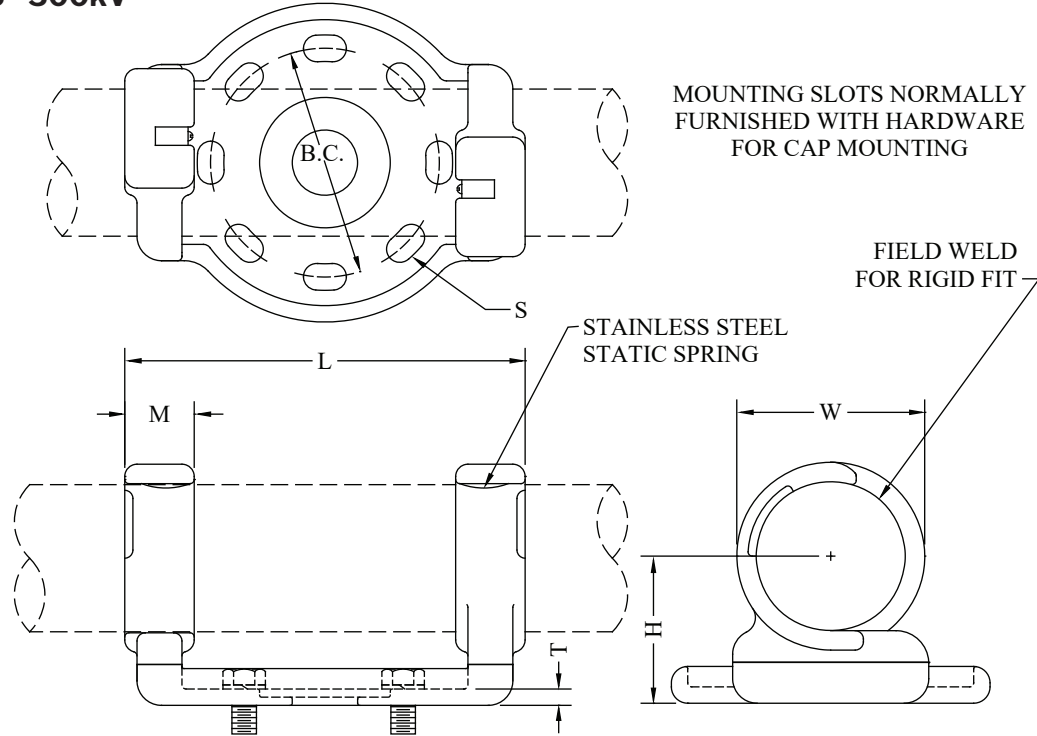

CATALOG NUMBER	PIPE SIZE (NPS)	BC	MAX KV	DIMENSIONS - INCHES						WEIGHT (POUNDS)
				H	L	M	S	W	T	
ASWH-58-5-EHV	2	5	345	2-3/4	10-1/8	2	11/16 x 1-1/16	3-1/2	3/8	5.90
ASWH-58-7-EHV		7	345	2-3/4	12-1/8	2	13/16 x 1-5/16	3-1/2	1/2	7.65
ASWH-60-5-EHV	2-1/2	5	345	3-1/8	10-1/8	2	11/16 x 1-1/16	4	3/8	6.20
ASWH-60-7-EHV		7	345	3-1/8	12-1/8	2	13/16 x 1-5/16	4	1/2	7.95
ASWH-62-5-EHV	3	5	345	3-5/8	10-1/8	2	11/16 x 1-1/16	4-1/2	3/8	6.40
ASWH-62-7-EHV		7	500	3-5/8	12-1/8	2	13/16 x 1-5/16	4-1/2	1/2	8.25
ASWH-63-5-EHV	3-1/2	5	500	4	10-1/4	2-1/8	11/16 x 1-1/16	5-5/16	3/8	7.55
ASWH-63-7-EHV		7	500	4	12-1/4	2-1/8	13/16 x 1-5/16	5-5/16	1/2	9.25
ASWH-64-5-EHV	4	5	500	4-1/2	10-1/4	2-1/8	11/16 x 1-1/16	5-3/4	3/8	8.05
ASWH-64-7-EHV		7	500	4-1/2	12-1/4	2-1/8	13/16 x 1-5/16	5-3/4	1/2	9.75
ASWH-67-5-EHV	5	5	500	5	10-1/4	2-1/8	11/16 x 1-1/16	7	3/8	9.05
ASWH-67-7-EHV		7	500	5	12-1/4	2-1/8	13/16 x 1-5/16	7	1/2	10.75
ASWH-69-5-EHV	6	5	500	5-1/2	12-7/8	2-1/4	11/16 x 1-1/16	8-1/8	3/8	9.40
ASWH-69-7-EHV		7	500	5-1/2	12-3/8	2-1/4	13/16 x 1-5/16	8-1/8	1/2	10.75

EHV BUS SUPPORTS

TYPE AVCAD

Bolted

Two Cables to Insulator

Casting Alloy: 356-T6 Aluminum
Clamping Hardware: Aluminum Alloy
Mounting Hardware: Galvanized Steel

ALUMINUM • 345kV

Type AVCAD is designed for corona-free service through 345kV. High-strength design with four clamping bolts per cable resists a differential sag and movement between the sub-conductors.

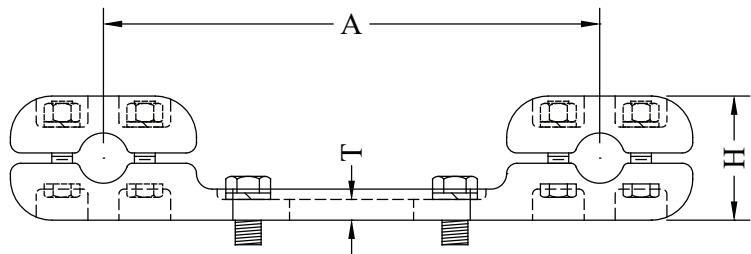
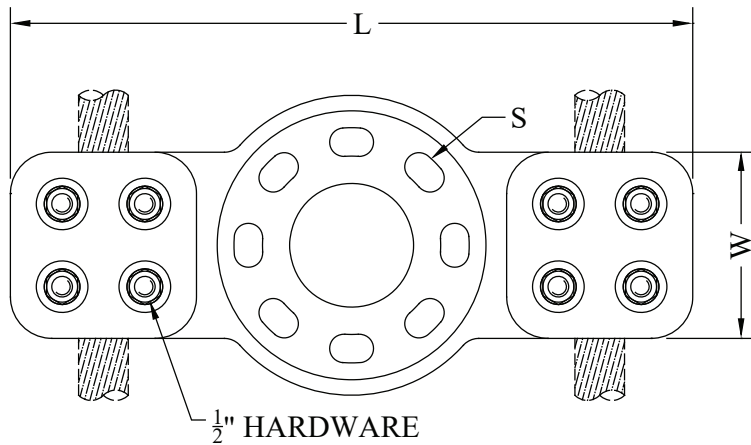

MOUNTING SLOTS NORMALLY
FURNISHED WITH HARDWARE

CATALOG NUMBER	CONDUCTOR RANGE (ACSR)	BOLT CIRCLE	DIMENSIONS - INCHES						WEIGHT (POUNDS)
			A	L	S	H	W	T	
AVCAD-32-5	???	5	12	16-1/4	11/16 x 1	2-3/4	4-1/4	1/2	9.75
AVCAD-32-7		7	15	19-1/4	13/16 x 1-1/4	2-3/4	4-1/4	1/2	11.25
AVCAD-35-5	795 - 954	5	12	16-1/2	11/16 x 1	2-7/8	4-1/2	1/2	10.00
AVCAD-35-7		7	15	19-3/8	13/16 x 1-1/4	2-7/8	4-1/4	1/2	11.50
AVCAD-38-5	1033 - 1113	5	12	16-1/2	11/16 x 1	3	4-1/2	1/2	10.25
AVCAD-38-7		7	15	19-1/2	13/16 x 1-1/4	3	4-1/2	1/2	11.75
AVCAD-41-5	1113 - 1272	5	12	16-5/8	11/16 x 1	3-1/4	4-1/4	1/2	10.50
AVCAD-41-7		7	15	19-5/8	13/16 x 1-1/4	3-1/8	4-1/2	1/2	12.00
AVCAD-43-5	1272 - 1431	5	12	16-3/4	11/16 x 1	3-1/4	4-1/2	1/2	10.75
AVCAD-43-7		7	15	19-3/4	13/16 x 1-1/4	3-1/4	4-1/2	1/2	12.25
AVCAD-46-5	1510 - 1590	5	12	17	11/16 x 1	3-3/8	4-1/4	1/2	11.00
AVCAD-46-7		7	15	20	13/16 x 1-1/4	3-3/8	4-1/2	1/2	12.50

EHV BUS SUPPORTS

TYPE AVCA-HV

Bolted

Cable to Insulator

Aluminum alloy designed for corona-free service at 345kV.

Casting Alloy: 356-T6 Aluminum

Mounting Hardware: Galvanized Steel

ALUMINUM • 345kV

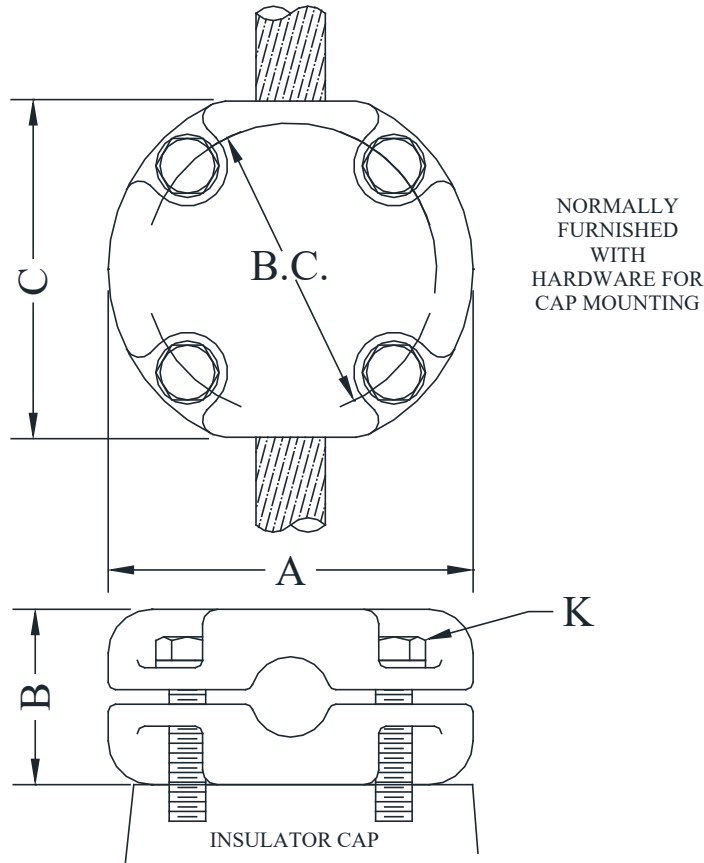

CATALOG NUMBER	CONDUCTOR RANGE		BOLT CIRCLE	DIMENSIONS - INCHES				WEIGHT (POUNDS)
	AAC	ACSR		A	B	C	K	
AVCA-HV-29-5	795	636 - 666	5	6-1/4	3	5-3/4	5/8	6.10
AVCA-HV-33-5	---	927	5	6-1/4	3	5-3/4	5/8	6.10
AVCA-HV-34-5	954 - 1033	795	5	6-1/4	3	5-3/4	5/8	6.10
AVCA-HV-36-5	1113	954 - 1033	5	6-1/4	3	5-3/4	5/8	6.10
AVCA-HV-39-5	1192 - 1272	1033 - 1113	5	6-1/4	3	5-3/4	5/8	6.10
AVCA-HV-43-5	1510 - 1590	1351 - 1431	5	6-1/4	3	5-3/4	5/8	6.10
AVCA-HV-46-5	---	1590	5	6-1/4	3	5-3/4	5/8	6.10

EHV BUS SUPPORTS

TYPE AVCHV

Bolted

Single Cable to Insulator

Type AVCHV is designed for corona-free service at 345kV.
Eight-slot base allows in-line or 45° orientation to insulator mounting.

Casting Alloy: 356-T6 Aluminum
Clamping Hardware: Aluminum Alloy
Mounting Hardware: Galvanized Steel

ALUMINUM • 345kV

NORMALLY FURNISHED WITH
HARDWARE FOR CAP MOUNTING

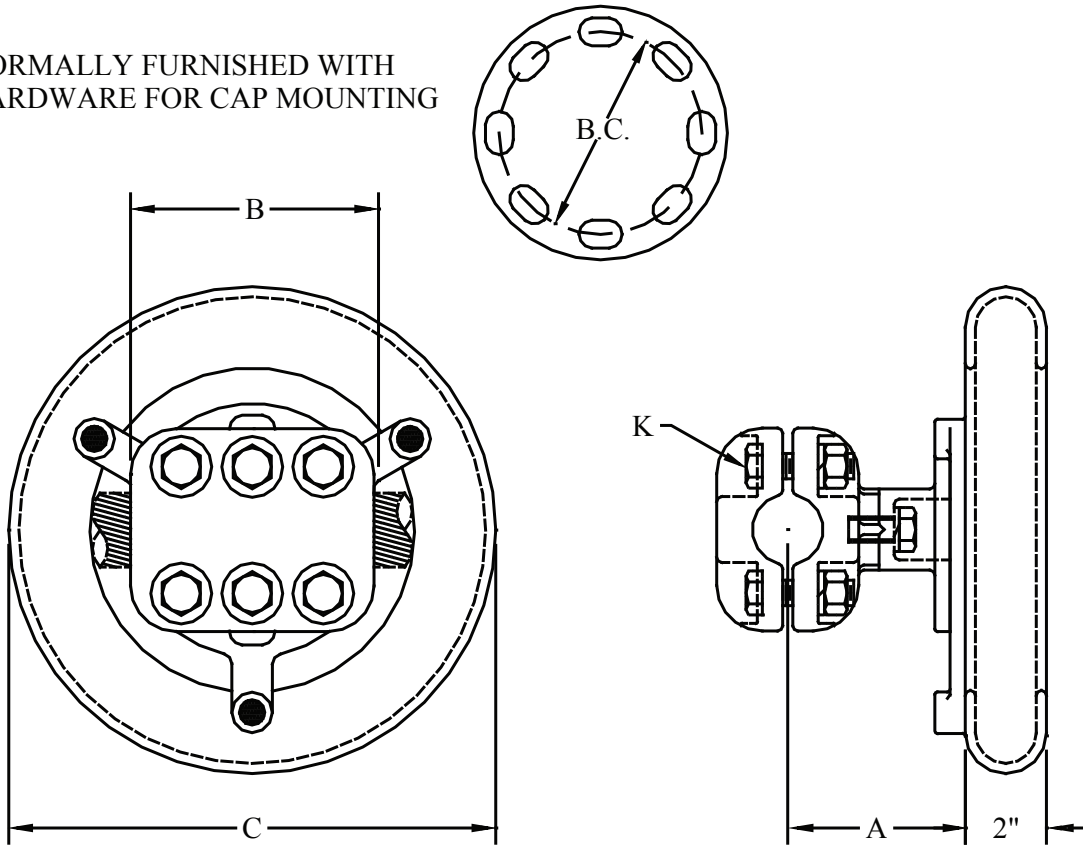

CATALOG NUMBER	CONDUCTOR DIAMETER		BOLT CIRCLE	DIMENSIONS - INCHES				WEIGHT (POUNDS)
	AAC	ACSR		A	B	C	K	
AVCHV-51-5	2250 - 2500	2156 - 2312	5	4-3/8	6	12	5/8	12.25
AVCHV-51-7			7	4-1/4	6	16-1/2	5/8	13.00
AVCHV-54-5	3000	----	5	4-3/8	6	12	5/8	14.00
AVCHV-54-7			7	4	6-1/2	14	5/8	14.75
AVCHV-56-5	???	???	5	4-1/2	6-1/2	12	5/8	14.50
AVCHV-56-7			7	4-1/2	6-1/2	14	5/8	15.25

EHV BUS SUPPORTS

TYPE WCTI-EHV
Weldment - Slide or Rigid
Pipe to Insulator

Type WCTI-EHV is designed for corona-free service within the voltage limitations of the bus, through 500kV.
Rigid fit is effected by welding at each end as shown.

Casting Alloy: 356-T6 Aluminum
Mounting Hardware: Galvanized Steel

ALUMINUM • 345 - 500kV

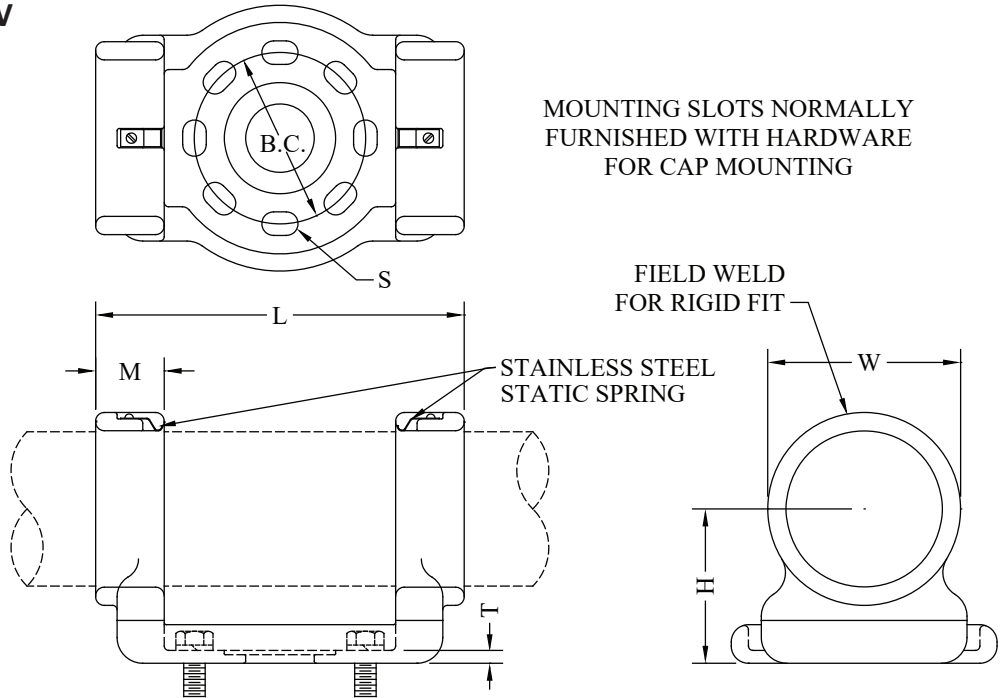

CATALOG NUMBER	PIPE SIZE (NPS)	BC	MAX KV	DIMENSIONS - INCHES						WEIGHT (POUNDS)
				H	L	M	S	W	T	
WCTI-58-5-EHV	2	5	345	2-3/4	9-3/4	2	11/16 x 1-1/16	3-3/8	1/2	5.55
WCTI-58-7-EHV		7	345	2-3/4	11-3/4	2	13/16 x 1-5/16	3-3/8	1/2	7.25
WCTI-60-5-EHV	2-1/2	5	345	3-1/8	9-3/4	1-1/2	11/16 x 1	3-7/8	3/8	6.30
WCTI-60-7-EHV		7	345	3-1/8	11-3/4	1-1/2	13/16 x 1-5/16	3-7/8	1/2	8.25
WCTI-62-5-EHV	3	5	500	3-5/8	10-3/4	2	11/16 x 1-1/16	4-1/2	1/2	7.15
WCTI-62-7-EHV		7	500	3-5/8	12-3/4	2	13/16 x 1-5/16	4-1/2	1/2	9.05
WCTI-63-5-EHV	3-1/2	5	500	4	10-3/4	2	11/16 x 1-1/16	5-1/8	1/2	8.00
WCTI-63-7-EHV		7	500	4	12-3/4	2	13/16 x 1-5/16	5-1/8	1/2	10.05
WCTI-64-5-EHV	4	5	500	4-1/2	10-3/4	2	11/16 x 1-1/16	5-5/8	3/8	9.00
WCTI-64-7-EHV		7	500	4-1/2	12-3/4	2	13/16 x 1-1/4	5-5/8	1/2	10.75
WCTI-67-5-EHV	5	5	500	5	11-1/2	2-3/8	11/16 x 1-1/16	6-3/4	3/8	10.00
WCTI-67-7-EHV		7	500	5	13-1/2	2-3/8	13/16 x 1-5/16	6-3/4	1/2	12.05
WCTI-69-5-EHV	6	5	500	5-1/2	11-1/2	2-3/8	11/16 x 1-1/16	7-3/4	3/8	11.00
WCTI-69-7-EHV		7	500	5-1/2	13-1/2	2-3/8	13/16 x 1-1/4	7-3/4	1/2	13.25

EHV BUS SUPPORTS

TYPE WRTIHV TYPE WRTIHV2

Weld Rigid Support
Pipe To Insulator

Type WRTIHV is corona-free at voltage levels shown in the table below. The open design allows this fitting to be used as a bus support or as a saddle for insulator support.
Type WRTIHV2 comprises two fittings mounted back-to-back as shown. Specify cap or base mounting.

NORMALLY FURNISHED WITH HARDWARE FOR CAP MOUNTING

Casting Alloy: 356-T6 Aluminum
Mounting Hardware: Galvanized Steel

ALUMINUM • 345 - 500kV

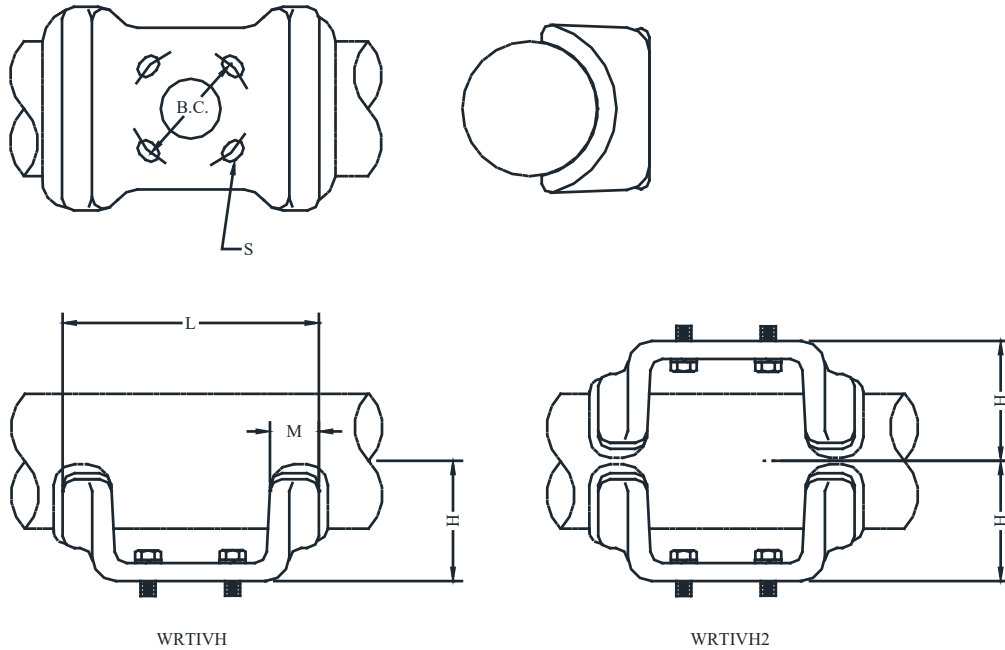

CATALOG NUMBERS		PIPE (NPS)	BC	MAX KV	DIMENSIONS - INCHES					WEIGHT (POUNDS)
FIG. 1	FIG. 2				H	L	M	S	T	
WRTIHV-58-5	WRTIHV2-58-5	2	5	345	2-3/4	8	1	11/16 x 1	1/2	2.50
WRTIHV-58-7	WRTIHV2-58-5		7	345	2-3/4	10	1	13/16 x 1-1/4	1/2	3.00
WRTIHV-60-5	WRTIHV2-60-5	2-1/2	5	345	3-1/8	8-1/4	1-1/8	11/16 x 1-1/16	7/16	2.26
WRTIHV-60-7	WRTIHV2-60-7		7	345	3-1/8	10-1/4	1-1/8	13/16 x 1-1/4	1/2	4.00
WRTIHV-62-5	WRTIHV2-62-5	3	5	500	3-5/8	8-1/2	1-1/4	11/16 x 1	1/2	4.26
WRTIHV-62-7	WRTIHV2-62-7		7	500	3-5/8	10-1/2	1-1/4	13/16 x 1-1/4	1/2	6.00
WRTIHV-63-5	WRTIHV2-63-5	3-1/2	5	500	4	8-1/2	1-1/4	11/16 x 1	1/2	6.00
WRTIHV-63-7	WRTIHV2-63-7		7	500	4	10-1/2	1-1/4	13/16 x 1-1/4	1/2	6.75
WRTIHV-64-5	WRTIHV2-64-5	4	5	500	4-1/2	8-1/2	1-1/4	11/16 x 1	7/16	4.51
WRTIHV-64-7	WRTIHV2-64-7		7	500	4-1/2	10-1/2	1-1/4	13/16 x 1-1/4	1/2	8.50
WRTIHV-67-5	WRTIHV2-67-5	5	5	500	5	10-3/4	2	11/16 x 1	3/4	8.30
WRTIHV-67-7	WRTIHV2-67-7		7	500	5	15-1/2	2	13/16 x 1-3/16	1/2	19.95
WRTIHV-69-5	WRTIHV2-69-5	6	5	500	5-1/2	8-1/2	1-1/4	11/16 x 1	1/2	11.50
WRTIHV-69-7	WRTIHV2-69-7		7	500	5-1/2	10-1/2	1-1/4	13/16 x 1-1/4	1/2	12.50

EHV BUS SUPPORTS

TYPE WSTIHV

Slide or Rigid Weldment
Pipe to Insulator

Casting Alloy: 356-T6 Aluminum
Static Spring: Stainless Steel
Mounting Hardware: Galvanized Steel

ALUMINUM • 345 - 500kV

Type WSTIHV is a low-profile bus support that may be applied as a rigid or slide fitting. Sliding action occurs between the base of the fitting and the insulator cap, instead of between bus and fitting. A disposable washer converts mounting hardware from rigid to slide fit. EHV ratings are shown in the table below.

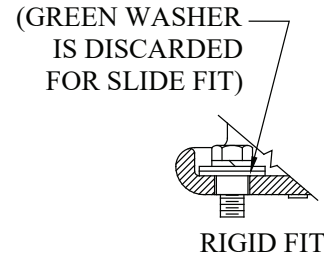
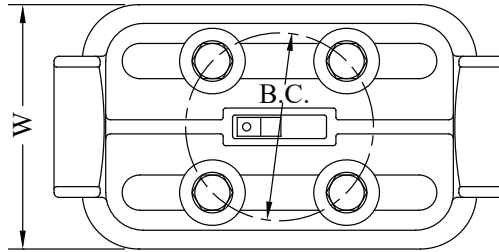

← 3" TOTAL EXCURSION →

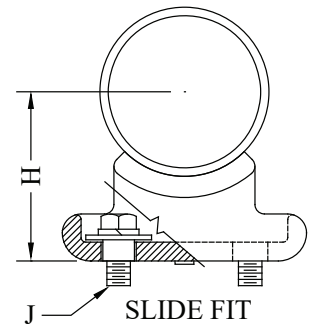
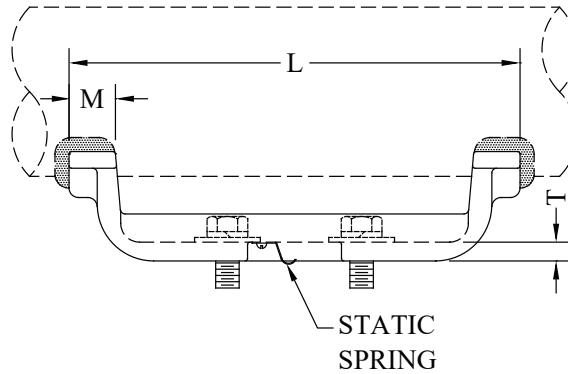

CATALOG NUMBER	PIPE SIZE (NPS)	BOLT CIRCLE	MAX KV	DIMENSIONS - INCHES						WEIGHT (POUNDS)
				H	L	M	J	W	T	
WSTIHV-58-5	2	5	345	2-3/4	11-1/2	1-1/8	5/8	6	1/2	3.00
WSTIHV-58-7		7	345	2-3/4	14	1-3/4	3/4	8-1/2	1/2	10.20
WSTIHV-60-5	2-1/2	5	345	3-1/8	11-1/2	1-1/8	5/8	6-1/4	1/2	3.65
WSTIHV-60-7		7	345	3-1/8	14	1-3/4	3/4	8-3/4	1/2	11.50
WSTIHV-62-5	3	5	500	3-5/8	11-3/4	1-1/8	5/8	6-1/2	1/2	5.65
WSTIHV-62-7		7	500	3-5/8	14-1/2	1-3/4	3/4	9	1/2	12.65
WSTIHV-63-5	3-1/2	5	500	4	12	1-1/4	5/8	6-1/2	1/2	5.65
WSTIHV-63-7		7	500	4	15-1/2	2	3/4	9	1/2	12.65
WSTIHV-64-5	4	5	500	4-1/2	12	1-1/4	5/8	6-1/2	1/2	5.65
WSTIHV-64-7		7	500	4-1/2	15-1/2	2	3/4	9	1/2	12.65
WSTIHV-67-5	5	5	500	5	10-3/4	2	5/8	7-1/4	1/2	5.65
WSTIHV-67-7		7	500	5	15-1/2	2	3/4	9	1/2	12.55
WSTIHV-69-5	6	5	500	5-1/2	12	1-1/4	5/8	6-1/2	1/2	5.90
WSTIHV-69-7		7	500	5-1/2	15-1/2	2	3/4	9	1/2	12.65

EHV BUS SUPPORTS

TYPE WVTI-CS1

Weld Vertical Support
Pipe to Insulator

Type WVTI-CS1 is a one-piece weldment support provided with auxiliary shield ring for 345kV service.

Casting Alloy: 356-T6 Aluminum
Shield Ring: Cast Aluminum
Mounting Hardware: Galvanized Ring

ALUMINUM • 345kV

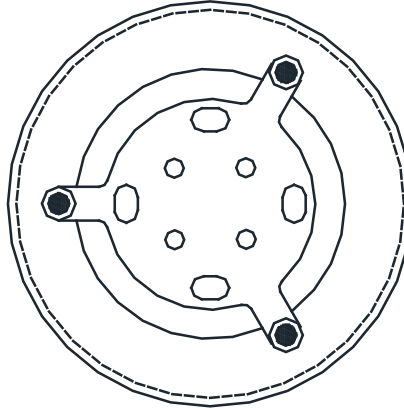

NORMALLY FURNISHED WITH
HARDWARE
FOR CAP MOUNTING

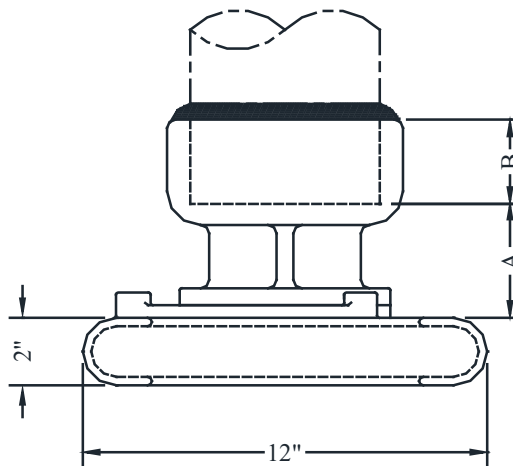

CATALOG NUMBER	PIPE SIZE (NPS)	BOLT CIRCLE	DIMENSIONS - INCHES		WEIGHT (POUNDS)
			A	B	
WVTI-58-5-CS1	2	5	1-1/2	7/8	7.50
WVTI-60-5-CS1	2-1/2	5	2-7/8	2	9.45
WVTI-62-5-CS1	3	5	2-7/8	1-3/4	10.45
WVTI-63-5-CS1	3-1/2	5	2-1/2	2	9.95
WVTI-64-5-CS1	4	5	3	2	12.75
WVTI-67-5-CS1	5	5	3-3/8	2-1/2	15.95
WVTI-69-5-CS1	6	5	3-3/8	3	15.50

EHV BUS SUPPORTS

TYPE WVTI-CS2

Weld Vertical Support
Pipe to Insulator

Type WVTI-CS2 is a one-piece weldment support provided with auxiliary shield ring for 500kV service.

Casting Alloy: 356-T6 Aluminum
Shield Ring: Tubular Aluminum
Mounting Hardware: Galvanized Steel

ALUMINUM • 500kV

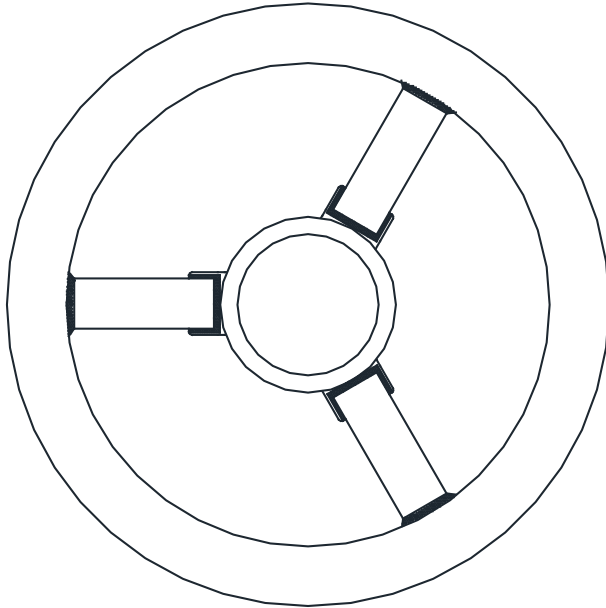

TOP VIEW

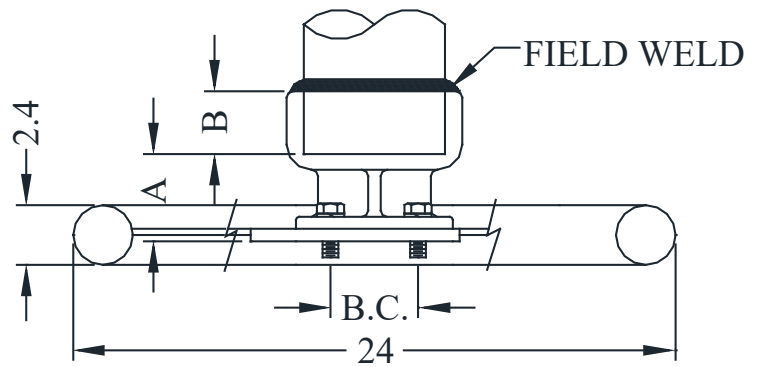

CATALOG NUMBER	PIPE SIZE (NPS)	BOLT CIRCLE	DIMENSIONS - INCHES		WEIGHT (POUNDS)
			A	B	
WVTI-62-5-CS2	3	5	3	1-3/4	14.45
WVTI-62-7-CS2		7	3	2	12.00
WVTI-63-5-CS2	3-1/2	5	3	2	11.00
WVTI-63-7-CS2		7	3	2	12.50
WVTI-64-5-CS2	4	5	3-1/8	2	16.75
WVTI-64-7-CS2		7	3	2	17.90
WVTI-67-5-CS2	5	5	3-1/2	2-1/2	20.00
WVTI-67-7-CS2		7	3-1/2	2-1/2	24.75
WVTI-69-5-CS2	6	5	3-1/2	3	19.45
WVTI-69-7-CS2		7	3-1/2	3	22.15

EHV BUS SUPPORTS

TYPE WVTSI-CS1

Vertical Slide Support
Pipe to Insulator

Type WVTSI-CS1 is a one-piece sliding support with auxiliary shield ring for 345kV service. Stainless steel static springs assure a noise-free movement.

Casting Alloy: 356-T6 Aluminum
Shield Ring: Cast Aluminum
Mounting Hardware: Galvanized Steel

ALUMINUM • 345kV

MOUNTING SLOTS NORMALLY
FURNISHED WITH HARDWARE
FOR CAP MOUNTING

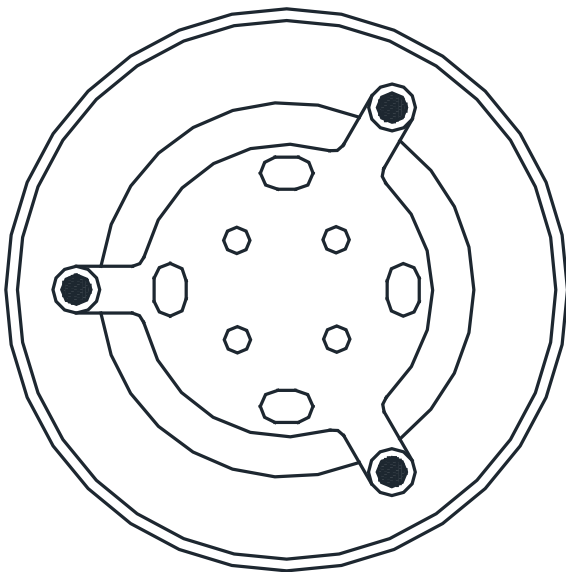

TOP VIEW

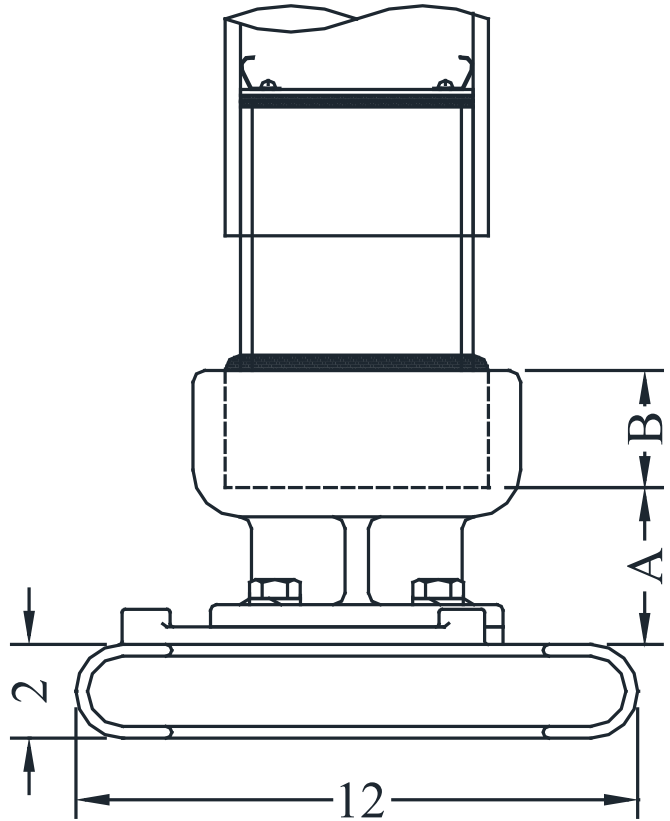

CATALOG NUMBER	PIPE SIZE (NPS)	BOLT CIRCLE MOUNTING	DIMENSIONS - INCHES		WEIGHT (POUNDS)
			A	B	
WVTSI-58-5-CS1	2	5	2-1/8	5-7/16	7.50
WVTSI-60-5-CS1	2-1/2	5	4-1/2	5	9.00
WVTSI-62-5-CS1	3	5	4-1/2	5	10.00
WVTSI-63-5-CS1	3-1/2	5	4-1/2	6	10.50
WVTSI-64-5-CS1	4	5	5-13/16	5-1/2	13.72
WVTSI-67-5-CS1	5	5	3-3/8	2-1/2	20.77
WVTSI-69-5-CS1	6	5	3-3/8	3	23.82

EHV BUS SUPPORTS

TYPE WVTSI-CS2

Vertical Slide Support
Pipe to Insulator

Type WVTSI-CS2 is a one-piece sliding support with auxiliary shield ring for 500kV service. Stainless steel static springs assure a noise-free movement.

Casting Alloy: 356-T6 Aluminum
Shield Ring: Tubular Aluminum
Mounting Hardware: Galvanized Steel

ALUMINUM • 500kV

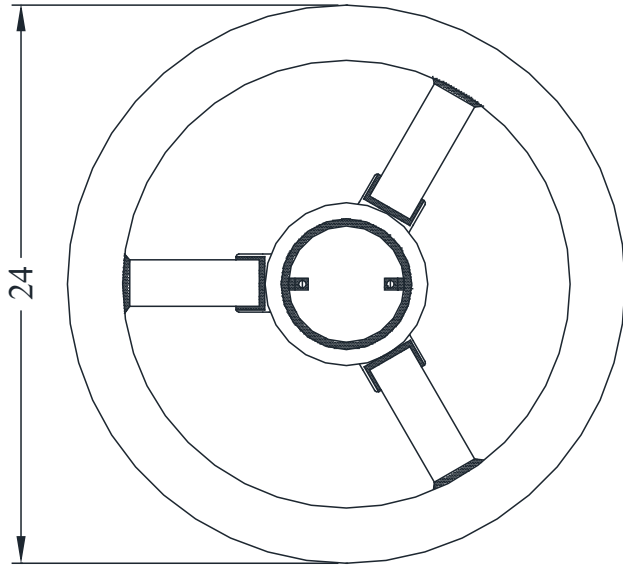

TOP VIEW

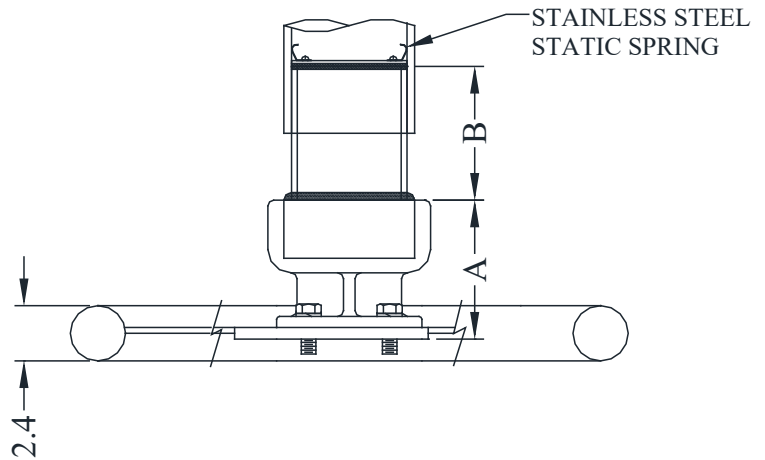

CATALOG NUMBER	PIPE SIZE (NPS)	BOLT CIRCLE MOUNTING	DIMENSIONS - INCHES		WEIGHT (POUNDS)
			A	B	
WVTSI-62-5-CS2	3	5	4-5/8	5-1/2	14.95
WVTSI-62-7-CS2		7	3-1/4	5-1/2	12.50
WVTSI-63-5-CS2	3-1/2	5	3-1/4	6	11.50
WVTSI-63-7-CS2		7	3-1/4	6	13.00
WVTSI-64-5-CS2	4	5	6	5-1/2	17.75
WVTSI-64-7-CS2		7	3-3/8	6	13.50
WVTSI-67-5-CS2	5	5	6	6	25.25
WVTSI-67-7-CS2		7	3-3/4	6-1/2	18.00
WVTSI-69-5-CS2	6	5	6-1/2	6	17.25
WVTSI-69-7-CS2		7	6-1/2	6	18.75

EHV BUS SUPPORTS

TYPE WXCCI

Welded Expansion Support
Pipe to Insulator

Casting Alloy: 356-T6 Aluminum
Flexible Elements: Class A Stranded Cable
Mounting Hardware: Galvanized Steel

Type WXCCI is self-shielding at voltages through 345kV by the flexible elements, which serve as corona rings.

Bus Length / temperature limits:

To obtain temperature that can be accommodated (°F), divide "X-Factor" by total bus length (both sides) in feet. To obtain maximum total bus length divide "X-Factor" by required temperature range (°F).

Bus lengths are to nearest fixed support.

ALUMINUM • 345kV

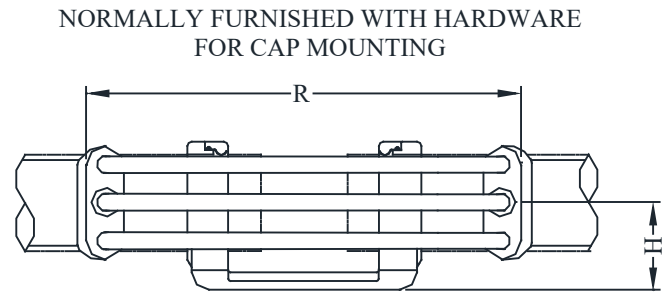
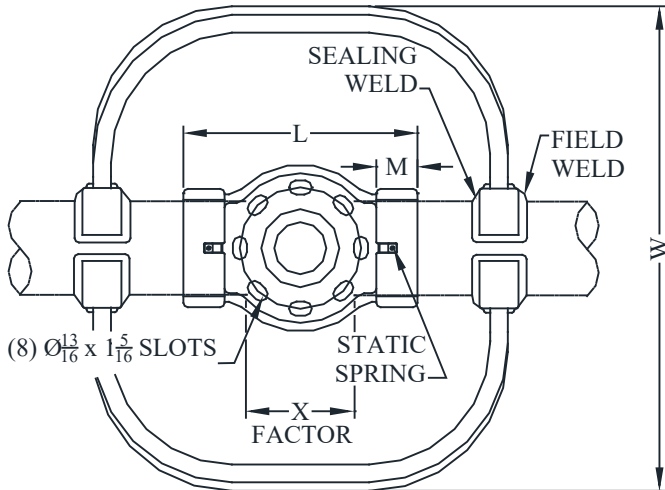

CATALOG NUMBER	PIPE SIZE	BC	X FACTOR	DIMENSIONS - INCHES					WEIGHT (POUNDS)
				H	L	M	R	W	
WXCCI-60-5	2-1/2" SCH 40	5	43945	3-1/8	10-1/4	1-3/4	21	21	16.00
WXCCI-60H-5	2-1/2" SCH 80	5	43945	3-1/8	10-1/4	1-3/4	21	21	16.00
WXCCI-62-5	3" SCH 40	5	43945	3-5/8	9-1/4	1-3/16	20	23	18.75
WXCCI-62H-5	3" SCH 80	5	43945	3-5/8	10-1/4	1-3/4	21	21	17.00
WXCCI-63-5	3-1/2" SCH 40	5	52083	4	13-1/4	2	26	30	24.55
WXCCI-63H-5	3-1/2" SCH 80	5	52083	4	13-1/4	2	26	24	17.50
WXCCI-64-5	4" SCH 40	5	52083	4-1/2	13-1/4	2	26-1/4	30	24.65
WXCCI-64H-5	4" SCH 80	5	52083	4-1/2	13-1/4	2	26	24	24.30
WXCCI-67-5	5" SCH 40	5	52083	5	14	2-3/8	25-1/4	28	35.00
WXCCI-67H-5	5" SCH 80	5	52083	5	14	2-3/8	25-1/4	28	34.30
WXCCI-69-5	6" SCH 40	5	52083	5-1/2	14	2-3/8	25-1/4	30-3/4	37.60
WXCCI-69H-5	6" SCH 80	5	52083	5-1/2	14	2-3/8	25-1/4	30-3/4	36.60

EHV BUS SUPPORTS

TYPE WXCTO-CS1

Welded Expansion
Pipe to Insulator

Type WXCTO-CS1 welded expansion bus supports provide corona-free service at 345kV

Maximum temperature range is obtained by dividing the "X-factor" by the total bus length (feet) between fixed supports.

Casting Alloy: 356-T6 Aluminum

Flexible Elements: 1100-0 Aluminum

Shield Rings: Tubular Aluminum

Mounting Hardware: Galvanized Steel

Maximum bus length between fixed supports is obtained by dividing the "X-factor" by the required temperature range (°F).

Slotted base allows angular adjustment of +4° from center line.

Weldment end plugs are furnished.

ALUMINUM • 345kV

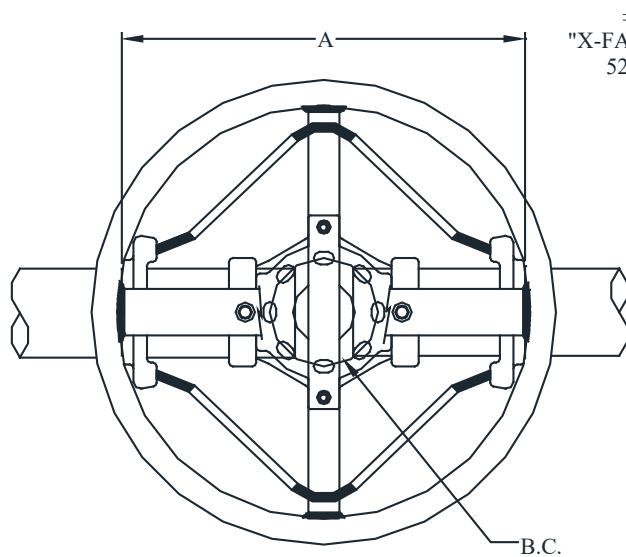

±4
"X-FACTOR"
52083

MOUNTING SLOTS NORMALLY
FURNISHED WITH HARDWARE
FOR CAP MOUNTING

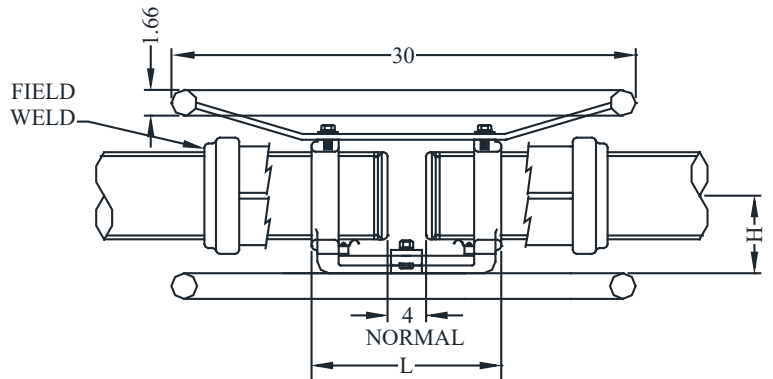

CATALOG NUMBER	PIPE SIZE (NPS)	BOLT CIRCLE	DIMENSIONS - INCHES			WEIGHT (POUNDS)
			A	H	L	
WXCTO-60-5-CS1	2-1/2	5	24	3-1/8	12-1/4	22.50
WXCTO-60-7-CS1		7	24	3-1/8	12-1/4	24.00
WXCTO-62-5-CS1	3	5	21-3/4	3-5/8	11-3/4	21.00
WXCTO-62-7-CS1		7	24	3-5/8	12-1/2	24.50
WXCTO-63-5-CS1	3-1/2	5	21-3/4	4	11-3/4	38.30
WXCTO-63-7-CS1		7	22-1/4	4	11-1/2	40.75
WXCTO-64-5-CS1	4	5	21-3/4	4-1/2	11-3/4	35.00
WXCTO-64-7-CS1		7	21-1/2	4-1/2	11-1/2	36.50
WXCTO-67-5-CS1	5	5	26	5	12-1/2	50.75
WXCTO-67-7-CS1		7	26-1/4	5	12-1/2	52.25
WXCTO-69-5-CS1	6	5	26-1/2	5-1/2	13	64.00
WXCTO-69-7-CS1		7	24-1/4	5-1/2	12-3/4	65.50

EHV BUS SUPPORTS

TYPE WXCTO-CS2

Welded Expansion
Pipe to Insulator

Casting Alloy: 356-T6 Aluminum
Flexible Elements: 1100-0 Aluminum
Shield Rings: Tubular Aluminum
Mounting Hardware: Galvanized Steel

ALUMINUM • 500kV

Type WXCTO-CS2 welded expansion bus supports provide corona-free service at 500kV.

Maximum temperature range is obtained by dividing the "X-factor" by the total bus length (feet) between fixed supports.

Maximum bus length between fixed supports is obtained by dividing the "X-factor" by the required temperature range (°F).

Slotted base allows angular adjustment of +4° from center line.

Weldment end plugs are furnished.

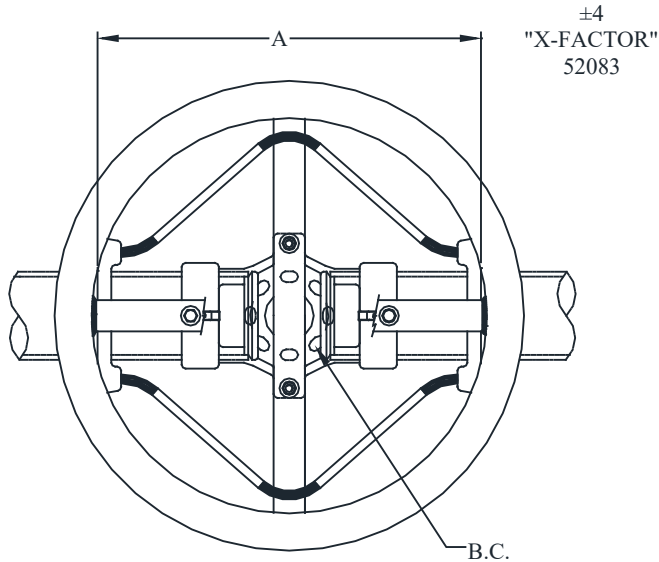

±4
"X-FACTOR"
52083

MOUNTING SLOTS NORMALLY
FURNISHED WITH HARDWARE
FOR CAP MOUNTING

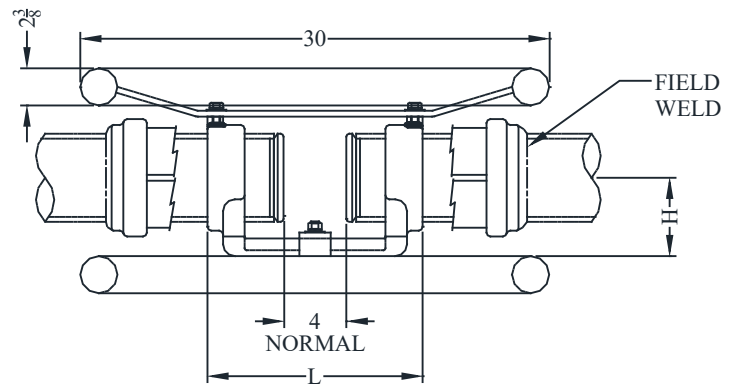

CATALOG NUMBER	PIPE SIZE (NPS)	BOLT CIRCLE	DIMENSIONS - INCHES			WEIGHT (POUNDS)
			A	H	L	
WXCTO-60-5-CS2	2-1/2	5	24	3-1/8	12-1/4	26.50
WXCTO-60-7-CS2		7	24	3-1/8	12-1/4	28.00
WXCTO-62-5-CS2	3	5	24	3-5/8	12-1/2	27.00
WXCTO-62-7-CS2		7	24	3-5/8	12-1/2	28.50
WXCTO-63-5-CS2	3-1/2	5	24	4	12-1/2	34.00
WXCTO-63-7-CS2		7	24	4	12-1/2	35.50
WXCTO-64-5-CS2	4	5	21-3/4	4-1/2	11-3/4	49.85
WXCTO-64-7-CS2		7	21-1/2	4-1/2	11-1/2	49.20
WXCTO-67-5-CS2	5	5	26	5	13-3/4	69.85
WXCTO-67-7-CS2		7	26	5	12-1/4	65.40
WXCTO-69-5-CS2	6	5	26-1/2	5-1/2	13	84.95
WXCTO-69-7-CS2		7	24-1/4	5-1/2	12-3/4	82.85

ALUMINUM, BRONZE, & EHV TEES

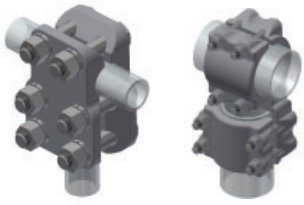

ATT ATTT



ATT-15



AVT15

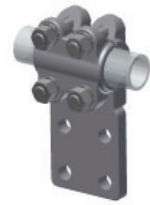

ATF



ATCXT



ATRCT



AXTF



ACRCT



ACF



WFTT



WFTT15



WFVT15



WTC



WTFR



WTF

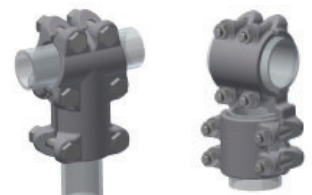

TTT TTHT



ATT15-BR



AVT15-BR



TTRCT

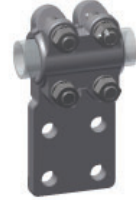

TFT



TCRCT



TFC



TTRDT TDRCT



ATTHV



AVTHV



ATTHV



ATFHV



ATFRHV



ACFHV2

ALUMINUM, BRONZE, & EHV TEES

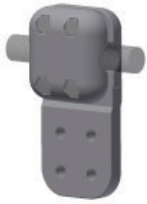

ACFHV



ACF2HV

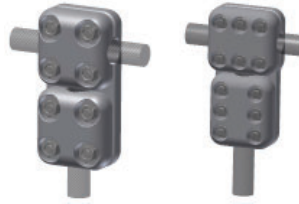

ACRCT-HV



ATCC-EHV/ATCF-EHV



WTF WFTR-EHV



WFTT-HV



WFVT-HV



WTTCC



WTTCC3



WTC

ALUMINUM TEE CONNECTORS

TYPE ACF

Bolted Straight

Cable Main to Flat Pad Tap

Aluminum alloy tee for aluminum cable to flat bar pads. NEMA hole drilling is standard. Clamping bolts have hex-stops for one-wrench installation. Contact sealant is recommended.

Also available for two cables to fat bar. Example: ACF2-13-2B

Wide cable ranges using reversible caps are available and are listed at the end of the table.

Casting Alloy: 356-T6 Aluminum
Clamping Hardware: Aluminum Alloy

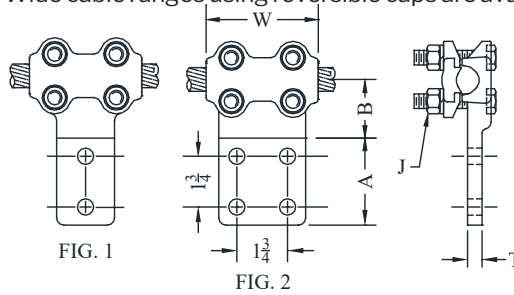

CATALOG NUMBER	FIG. NO.	CONDUCTOR RANGE		PAD WIDTH	DIMENSIONS - INCHES					WEIGHT (POUNDS)
		AAC	ACSR		A	B	W	T	J	
ACF-13-2B	1	#4 - 266 MCM	#4 - 4/0 MCM	2	3	1-3/4	3	5/16	1/2	1.25
ACF-13-4A	2			3	3	1-3/4	3	5/16	1/2	1.25
ACF-13-4B	2			4	4	3-1/2	3	3/8	1/2	1.95
ACF-20-2B	1	4/0 - 500 MCM	4/0 - 397 MCM	2	3	1-7/8	3-1/2	1/2	1/2	1.80
ACF-20-4A	2			3	3	1-7/8	3-1/2	1/2	1/2	1.80
ACF-20-4B	2			4	4	1-9/16	3-1/2	1/2	1/2	2.30
ACF-24-2B	1	350 - 650 MCM	267-556 MCM	2	3	2-1/8	4	1/2	1/2	1.80
ACF-24-4A	2			3	3	2	4	1/2	1/2	1.80
ACF-24-4B	2			4	4	2-1/8	4	1/2	1/2	2.30
ACF-34-2B	1	550 - 1000 MCM	477 - 795 MCM	2	3	2-1/8	4	5/8	1/2	2.55
ACF-34-4A	2			3	3	2-1/8	4	5/8	1/2	2.55
ACF-34-4B	2			4	4	2-5/16	4	5/8	1/2	2.70
ACF-39-2B	1	874-1300 MCM	715 - 1113 MCM	2	3	2-1/2	4-1/4	1/2	1/2	1.85
ACF-39-4A	2			3	3	2-3/8	4-1/4	5/8	1/2	2.10
ACF-39-4B	2			4	4	2	4-1/4	5/8	1/2	2.95
ACF-43-2B	1	1250 - 1590 MCM	1113 - 1431 MCM	2	3	2-1/2	4-1/2	3/4	1/2	3.15
ACF-43-4A	2			3	3	2-1/2	4-1/2	3/4	1/2	3.15
ACF-43-4B	2			4	4	2-1/4	4-1/2	3/4	5/8	3.90
ACF-46-2B	1	1250 - 1800 MCM	1113 - 1590 MCM	2	3	4-3/8	4-3/4	3/4	5/8	4.25
ACF-46-4A	2			3	3	2-3/8	4-3/4	3/4	5/8	4.25
ACF-46-4B	2			4	4	4-3/4	4-3/4	3/4	5/8	4.25
ACF-49-2B	1	1500 - 2000 MCM	1272 - 2034 MCM	2	3	2-1/4	4-3/4	3/4	5/8	5.25
ACF-49-4A	2			3	3-1/2	2-1/4	4-3/4	3/4	5/8	5.25
ACF-49-4B	2			4	4	2-1/4	4-3/4	3/4	5/8	5.25
ACF-56-4B*	---	2000 - 3500 MCM	2034 - 3064 MCM	4	4	2-11/16	6	1	5/8	7.75
ACF-1139-2B	1	4/0 - 1431 MCM	4/0 - 1272 MCM	2	3	2-1/2	4-1/4	1/2	1/2	2.10
ACF-1139-4A	2			3	3	2-1/4	4-1/4	5/8	1/2	2.35
ACF-1139-4B	2			4	4	2	4-1/4	5/8	1/2	3.20
ACF-1020-4A	2	#1 - 500 MCM	#2 - 397.5 MCM	3	3	1-7/8	3-1/2	1/2	1/2	1.80
ACF-3653-4B	2	CONTACT FACTORY FOR DETAILS								

* Six clamping bolts per cap



Return To Index

ALUMINUM TEE CONNECTORS

TYPE ACRCT

Bolted Straight

Cable Main to Cable Tap

Aluminum alloy tee for aluminum cable to cable connections.

Clamping bolts have hex-stops for one-wrench installation.

Contact sealant is recommended.

Wide cable ranges using reversible caps are available and are listed at the end of the table.

Casting Alloy: 356-T6 Aluminum
Clamping Hardware: Aluminum Alloy

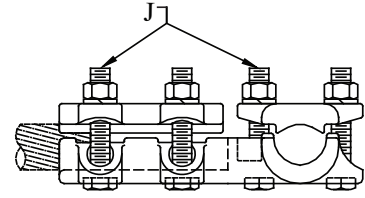
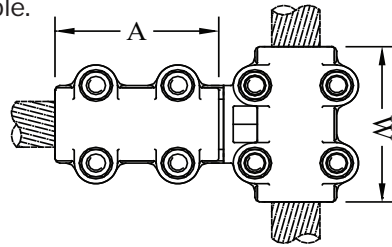

CATALOG NUMBER	DIMENSIONS				DIMENSIONS INCHES			WEIGHT (POUNDS)
	CABLE MAIN (MCM)		CABLE TAP (MCM)		A	W	J	
	AAC	ACSR	AAC	ACSR				
ACRCT-1313	#4 - 266	#4 - 4/0	#4 - 266	#4 - 4/0	3	3	1/2	1.55
ACRCT-2013	4/0 - 500	4/0 - 397	#4 - 266	#4 - 4/0	3	3-1/2	1/2	2.05
ACRCT-2020			4/0 - 500	4/0 - 397	3-1/2	3-1-2	1/2	2.35
ACRCT-2413	350 - 650	336 - 556	#4 - 266	#4 - 4/0	3	4	1/2	2.30
ACRCT-2420			4/0 - 500	4/0 - 397	3-1/2	4	1/2	2.60
ACRCT-2424			350 - 650	336 - 556.4	4	4	1/2	2.60
ACRCT-3413	550 - 1000	477 - 795	#4 - 266	#4 - 4/0	3	4	1/2	2.35
ACRCT-3420			4/0 - 500	4/0 - 397	3-1/2	4	1/2	2.85
ACRCT-3424			350 - 650	336 - 556.4	4	4	1/2	3.05
ACRCT-3434			550 - 1000	477 - 795	4	4	1/2	3.15
ACRCT-3913	900 - 1300	715 - 1113	#4 - 266	#4 - 4/0	3	4-1/4	1/2	2.55
ACRCT-3920			4/0 - 500	4/0 - 397	3-1/2	4-1/4	1/2	2.90
ACRCT-3924			350 - 650	336 - 556.4	4	4-1/4	1/2	3.90
ACRCT-3934			550 - 1000	477 - 795	4	4-1/4	1/2	4.05
ACRCT-3939			874.5 - 1300	715.5 - 1113	4-1/4	4-1/4	1/2	3.00
ACRCT-4313	1250-1590	1113-1431	#4 - 266	#4 - 4/0	3	4-1/2	1/2	3.65
ACRCT-4320			4/0 - 500	4/0 - 397	3-1/2	4-1/2	1/2	4.15
ACRCT-4324			350 - 650	336 - 556.4	4	4-1/2	1/2	3.90
ACRCT-4334			550 - 1000	477 - 795	4	4-1/2	1/2	3.95
ACRCT-4339			874.5 - 1300	715.5 - 1113	4-1/4	4-1/2	1/2	3.95
ACRCT-4343			1250 - 1590	1113 - 1431	4-1/2	4-1/2	5/8	5.30
ACRCT-4646	1250 - 1800	1113 - 1590	1250 - 1800	1113 - 1590	4-3/4	4-3/4	5/8	5.55
ACRCT-4949	1500 - 2000	1272 - 2034	1500 - 2000	1272 - 2034	4-3/4	4-3/4	5/8	8.30
ACRCT-5656*	2000 - 2500	1780 - 2156	2000 - 2500	1780 - 2156	6	6	5/8	9.80
ACRCT-1020-1020	#1 - 500	#2 - 397.5	#1 - 500	#2 - 397.5	3-1/2	3-1/2	1/2	2.35
ACRCT-1139-1020	4/0-1113	4/0 - 1113			4	4	1/2	3.15
ACRCT-1139-1139			4/0 - 1300	4/0 - 1272	4-1/4	4-1/4	1/2	3.50
ACRCT-3653-3653	1100 - 2500	1113 - 2300	1100 - 2500	1113 - 2300	4	6-3/4	5/8	6.40

* Six clamping bolts per cap

SEFCOR

Return To Index

ALUMINUM TEE CONNECTORS

TYPE ATCXT

Bolted Straight
Tee/Coupler Pipe to Pipe

Aluminum alloy tee / coupler for coupling aluminum pipe with 90° aluminum pipe tap. Clamping bolts have hex-stops for one-wrench installation.

Casting Alloy: 356-T6 Aluminum
Clamping Hardware: Aluminum Alloy

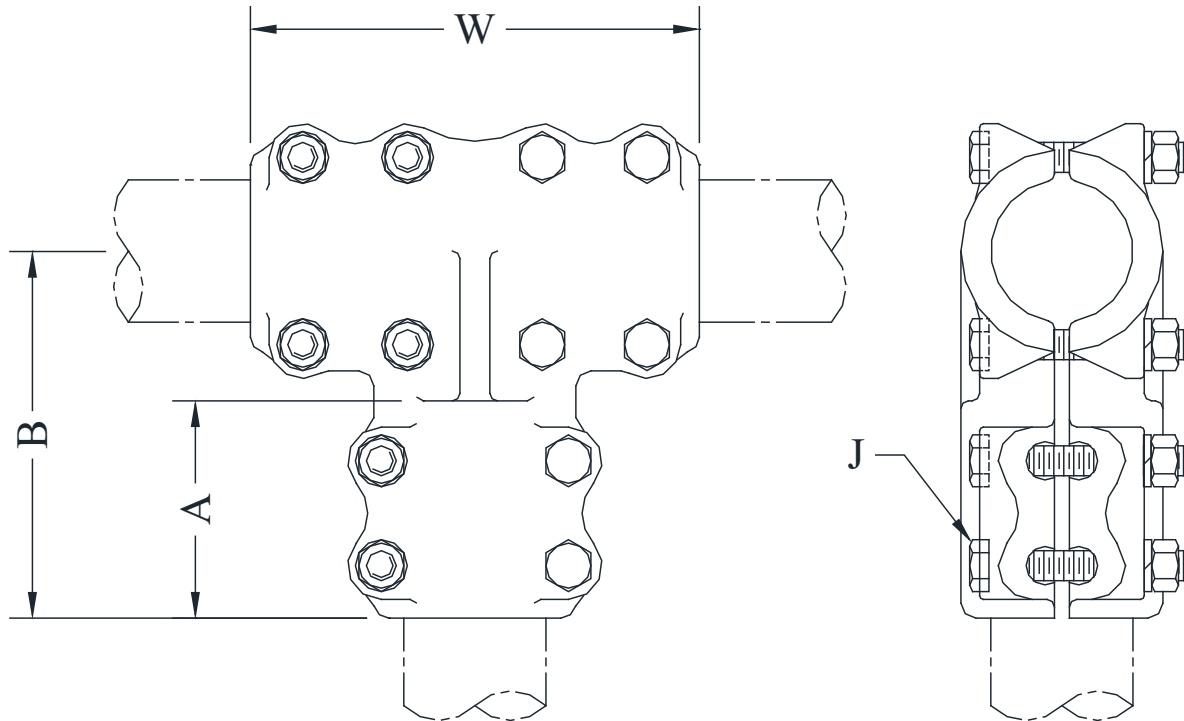

CATALOG NUMBER	CONDUCTOR SIZE (NPS)		DIMENSIONS - INCHES				WEIGHT (POUNDS)
	PIPE MAIN	PIPE TAP	A	B	W	J	
ATCXT-3030	3/4	3/4	2-9/16	4	5-3/8	1/2	3.35
ATCXT-3939	1	1	2-3/4	4-5/8	6-1/8	1/2	3.85
ATCXT-4949	1-1/4	1-1/4	3-1/4	5-1/4	7	1/2	3.85
ATCXT-5353	1-1/2	1-1/2	3	4-15/16	6-1/2	1/2	5.55
ATCXT-5858	2	2	3-5/8	6-1/8	7-1/2	1/2	7.05
ATCXT-6060	2-1/2	2-1/2	3-3/8	6-1/16	7-5/8	1/2	11.55
ATCXT-6262	3	3	4	7-3/8	10-1/8	5/8	13.70
ATCXT-6363	3-1/2	3-1/2	5-1/4	8-9/16	11	5/8	15.70
ATCXT-6464	4	4	4-1/2	13-1/4	12	5/8	27.30
ATCXT-6767	5	5	7	11-5/8	14	5/8	45.70
ATCXT-6969	6	6	7	17-1/8	12-3/4	5/8	48.65

* Consult manufacturer for further details or unlisted applications.

ALUMINUM TEE CONNECTORS

TYPE ATF

Bolted Straight
Pipe to Flat

Aluminum alloy tee for aluminum pipe to flat bar pads. NEMA hole drilling is standard. Clamping bolts have hex-stops for one-wrench installation. Contact sealant is recommended.

Casting Alloy: 356-T6 Aluminum
Clamping Hardware: Aluminum Alloy

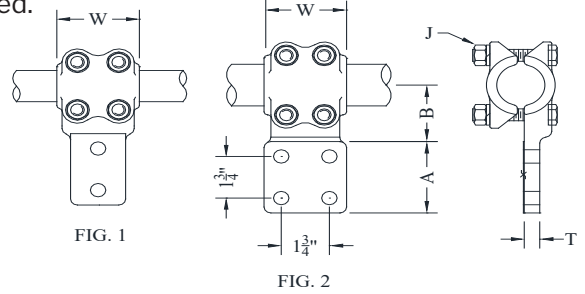

CATALOG NUMBER	FIG. NO.	CONDUCTOR SIZE		DIMENSIONS - INCHES					WEIGHT (POUNDS)
		PIPE MAIN	PAD WIDTH	A	B	W	T	J	
ATF-30-2B	1	3/4	2	3	1-7/8	2-3/8	3/8	1/2	1.40
ATF-30-4A	2		3	3	1-7/8	2-3/8	3/8	1/2	1.50
ATF-30-4B	2		4	4-1/4	1-7/8	2-3/8	3/8	1/2	2.00
ATF-39-2B	1	1	2	3	2	3	1/2	1/2	1.80
ATF-39-4A	2		3	3-3/8	1-3/4	3	1/2	1/2	1.85
ATF-39-4B	2		4	4	2-1/8	3	1/2	1/2	2.10
ATF-49-2B	1	1-1/4	2	3	2-3/8	3	9/16	1/2	2.10
ATF-49-4A	2		3	3	2-3/8	3	9/16	1/2	2.10
ATF-49-4B	2		4	4	2-1/2	3	3/8	1/2	2.10
ATF-53-2B	1	1-1/2	2	3	2-1/2	3-1/8	1/2	1/2	2.10
ATF-53-4A	2		3	3	2-1/2	3-1/8	1/2	1/2	2.35
ATF-53-4B	2		4	4	2-1/4	3	1/2	1/2	2.30
ATF-58-2B	1	2	2	3	2-3/4	3-1/2	5/8	1/2	2.35
ATF-58-4A	2		3	3	2-3/4	3-1/2	1/2	1/2	2.60
ATF-58-4B	2		4	4	2-3/4	3-1/2	7/16	1/2	3.00
ATF-60-2B	1	2-1/2	2	3	3-1/8	3-1/2	5/8	1/2	3.10
ATF-60-4A	2		3	3	3-1/8	3-1/2	5/8	1/2	3.10
ATF-60-4B	2		4	4	3-1/4	3-1/2	5/8	1/2	3.75
ATF-62-2B	1	3	2	3	3-3/8	3-1/2	1	1/2	2.95
ATF-62-4A	2		3	3	3-3/8	3-1/2	3/4	1/2	3.15
ATF-62-4B	2		4	4	3-1/4	3-1/2	3/4	1/2	4.20
ATF-63-2B	1	3-1/2	2	3-1/4	3-3/8	3-1/4	3/4	1/2	4.65
ATF-63-4A	2		3	3-1/4	3-3/8	3-1/4	3/4	1/2	4.65
ATF-63-4B	2		4	4	3-3/8	3-1/4	3/4	1/2	4.90
ATF-64-2B	1	4	2	3	3-3/4	3-1/4	3/4	1/2	3.95
ATF-64-4A	2		3	3	4-1/2	4-1/2	3/4	5/8	8.00
ATF-64-4B	2		4	4	4-1/2	4-1/2	3/4	5/8	8.00
ATF-67-4B	2	5	4	4	5-3/8	4-3/4	1	5/8	12.90
ATF-69-4B	2	6	4	4	5-1/2	7	1-1/8	5/8	18.30

*Consult manufacturer for further details or unlisted applications.

ALUMINUM TEE CONNECTORS

TYPE ATRCT

Bolted Straight

Pipe Main to Cable Tap

Aluminum alloy tee for aluminum pipe to cable connections. Clamping bolts have hex-stops for one-wrench installation. Contact sealant is recommended.

Casting Alloy: 356-T6 Aluminum
Clamping Hardware: Aluminum Alloy

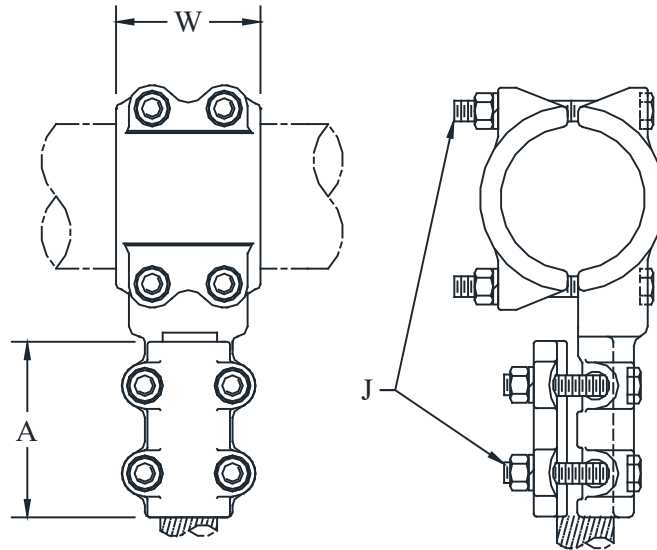

CATALOG NUMBER	CONDUCTOR RANGE		DIMENSIONS - INCHES			WEIGHT (POUNDS)	
	PIPE MAIN	CABLE TAP		A	W		J
		AAC	ACSR				
ATRCT-3013	3/4	#4 - 266 MCM	#4 - 4/0	3	2-3/8	1/2	2.05
ATRCT-3020		4/0 - 500 MCM	4/0 - 397 MCM	3-1/2	4	1/2	2.85
ATRCT-3024		350 - 650 MCM	336 - 556 MCM	4	2-3/8	1/2	2.55
ATRCT-3913	1	#4 - 266 MCM	#4 - 4/0	3	3	1/2	2.05
ATRCT-3920		4/0 - 500 MCM	4/0 - 397 MCM	3-1/2	3	1/2	2.55
ATRCT-3924		350 - 650 MCM	336 - 556 MCM	4	3	1/2	2.55
ATRCT-3934		550 - 1000 MCM	477 - 795 MCM	4	3	1/2	2.90
ATRCT-4920	1-1/4	4/0 - 500 MCM	4/0 - 397 MCM	3-1/2	2-3/4	1/2	2.35
ATRCT-4924		350 - 650 MCM	336 - 556 MCM	4	3	1/2	2.60
ATRCT-4934		550 - 1000 MCM	477 - 795 MCM	4	3	1/2	2.60
ATRCT-5313	1-1/2	#4 - 266 MCM	#4 - 4/0	3	3-1/8	1/2	2.85
ATRCT-5320		4/0 - 500 MCM	4/0 - 397 MCM	3-1/2	3	1/2	2.90
ATRCT-5324		350 - 650 MCM	336 - 556 MCM	4	3	1/2	3.15
ATRCT-5334		550 - 1000 MCM	477 - 795 MCM	4	3-1/8	1/2	3.40
ATRCT-5339		874 - 1300 MCM	715 - 1113 MCM	4-1/4	3-1/8	1/2	3.45
ATRCT-5813	2	#4 - 266 MCM	#4 - 4/0	3	3-1/2	1/2	3.10
ATRCT-5820		4/0 - 500 MCM	4/0 - 397 MCM	3-1/2	3-1/2	1/2	3.15
ATRCT-5824		350 - 650 MCM	336 - 556 MCM	3-7/8	3-1/2	1/2	3.65
ATRCT-5834		550 - 1000 MCM	477 - 795 MCM	4	3-1/2	1/2	3.35
ATRCT-5839		874 - 1300 MCM	715 - 1113 MCM	4-1/4	3-1/2	1/2	3.95
ATRCT-5843		1250 - 1590 MCM	1113 - 1431 MCM	4-1/2	3-1/2	1/2	4.70

ALUMINUM TEE CONNECTORS

TYPE ATRCT - Continued

CATALOG NUMBER	CONDUCTOR RANGE		DIMENSIONS - INCHES			WEIGHT (POUNDS)	
	PIPE MAIN	CABLE TAP		A	W		J
		AAC	ACSR				
ATRCT-6013	2-1/2	#4 - 266 MCM	#4 - 4/0	3	3-1/2	1/2	3.35
ATRCT-6020		4/0 - 500 MCM	4/0 - 397 MCM	3-1/2	3-1/2	1/2	3.65
ATRCT-6024		350 - 650 MCM	336 - 556 MCM	4	3-1/2	1/2	3.90
ATRCT-6034		550 - 1000 MCM	477 - 795 MCM	4	3-1/2	1/2	3.90
ATRCT-6039		874 - 1300 MCM	715 - 1113 MCM	4-1/4	3-1/2	1/2	4.20
ATRCT-6043		1250 - 1590 MCM	1113 - 1431 MCM	4-1/2	3-1/2	1/2	4.70
ATRCT-6213	3	#4 - 266 MCM	#4 - 4/0	3	3-1/2	1/2	2.85
ATRCT-6220		4/0 - 500 MCM	4/0 - 397 MCM	3-1/2	3	1/2	3.05
ATRCT-6224		350 - 650 MCM	336 - 556 MCM	4	3-1/2	1/2	5.25
ATRCT-6234		550 - 1000 MCM	477 - 795 MCM	4	3-1/2	1/2	5.25
ATRCT-6239		874 - 1300 MCM	715 - 1113 MCM	4-1/4	3-1/2	1/2	5.30
ATRCT-6243		1250 - 1590 MCM	1113 - 1431 MCM	4-1/2	4	5/8	6.85
ATRCT-6320	3-1/2	4/0 - 500 MCM	4/0 - 397 MCM	3-1/2	3-1/4	1/2	4.45
ATRCT-6324		350 - 650 MCM	336 - 556 MCM	4	3-1/4	1/2	4.20
ATRCT-6334		550 - 1000 MCM	477 - 795 MCM	4	3-1/4	1/2	4.75
ATRCT-6339		874 - 1300 MCM	715 - 1113 MCM	4-1/4	3-1/4	1/2	5.05
ATRCT-6343		1250 - 1590 MCM	1113 - 1431 MCM	4-1/2	4-3/8	5/8	8.05
ATRCT-6420	4	4/0 - 500 MCM	4/0 - 397 MCM	3-1/2	3-1/4	1/2	5.50
ATRCT-6424		350 - 650 MCM	336 - 556 MCM	4	3-1/4	1/2	6.20
ATRCT-6434		550 - 1000 MCM	477 - 795 MCM	4	3-1/4	1/2	4.60
ATRCT-6439		874 - 1300 MCM	715 - 1113 MCM	4-1/4	3-1/4	1/2	6.30
ATRCT-6443		1250 - 1590 MCM	1113 - 1431 MCM	4-1/2	4-1/2	5/8	9.40
ATRCT-6449		1500 - 2000 MCM	1351 - 1780 MCM	4-3/4	4-1/2	5/8	7.75

*Consult manufacturer for further details or unlisted applications.

ALUMINUM TEE CONNECTORS

TYPE ATT & ATTT

Straight Bolted
Pipe Main to Pipe Tap

Casting Alloy: 356-T6 Aluminum
Clamping Hardware: Aluminum Alloy

Aluminum alloy tee for aluminum pipe main to aluminum pipe tap connections. Clamping bolts have hex-stops for one-wrench installation. Contact sealant is recommended.

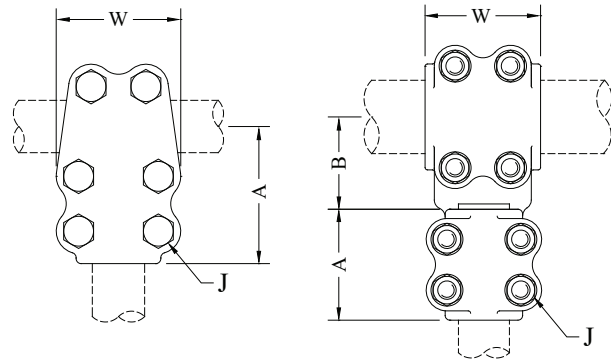

TYPE ATT

TYPE ATTT

CATALOG NUMBER	CONDUCTOR SIZE (NPS)		DIMENSIONS - INCHES				WEIGHT (POUNDS)
	PIPE MAIN	PIPE TAP	A	B	W	J	
ATT-3030	3/4	3/4	2-13/16	----	2-3/8	1/2	1.45
ATT-3930	1	3/4	3-7/16	----	2-7/8	1/2	1.45
ATT-3939		1	3-7/16	----	3-1/8	1/2	1.95
ATTT-4930	1-1/4	3/4	3-3/8	2	2-3/4	1/2	2.75
ATTT-4939		1	3	2	2-3/4	1/2	3.00
ATTT-4949		1-1/4	3	2-5/16	3	1/2	2.85
ATTT-5330	1-1/2	3/4	2-1/2	2	3-1/8	1/2	3.25
ATTT-5339		1	3	2-1/2	3-1/8	1/2	3.65
ATTT-5349		1-1/4	3	2-1/2	3-1/8	1/2	3.50
ATTT-5353		1-1/2	3-1/8	2-5/8	3-1/8	1/2	3.95
ATTT-5839	2	1	3	2-5/8	3-1/2	1/2	2.90
ATTT-5849		1-1/4	3	2-7/8	3-1/2	1/2	3.40
ATTT-5853		1-1/2	3-1/8	2-5/8	3-1/2	1/2	3.45
ATTT-5858		2	3-1/2	2-15/16	3-1/2	1/2	4.45
ATTT-6039	2-1/2	1	3	3	3-1/2	1/2	4.00
ATTT-6049		1-1/4	3	3	3-1/2	1/2	4.00
ATTT-6053		1-1/2	3-1/8	3	3-1/2	1/2	4.45
ATTT-6058		2	3-1/2	3	3-1/2	1/2	4.15
ATTT-6060		2-1/2	3-1/2	3-1/8	3-1/2	1/2	5.70
ATTT-6239	3	1	3	3-1/16	3	1/2	2.95
ATTT-6249		1-1/4	3	3-1/4	3-1/2	1/2	5.30
ATTT-6253		1-1/2	3-1/8	3-1/4	3-1/2	1/2	5.05
ATTT-6258		2	3-1/2	3-1/2	3-1/2	1/2	5.80
ATTT-6260		2-1/2	3-1/2	3-3/8	3-1/2	1/2	6.05
ATTT-6262		3	4	3-3/4	4	5/8	8.95

* Consult manufacturer for further details or unlisted applications.

Continued on next page

ALUMINUM TEE CONNECTORS

TYPES ATT & ATTT - CONTINUED

CATALOG NUMBER	CONDUCTOR SIZE (NPS)		DIMENSIONS - INCHES				WEIGHT (POUNDS)
	PIPE MAIN	PIPE TAP	A	B	W	J	
ATTT-6339	3-1/2	1	4-1/4	3-1/2	3-1/4	1/2	5.35
ATTT-6349		1-1/4	3	3-1/2	3-1/4	1/2	4.20
ATTT-6353		1-1/2	3-1/8	3-1/2	3-1/4	1/2	5.75
ATTT-6358		2	3-1/2	3-1/2	3-1/4	1/2	8.00
ATTT-6360		2-1/2	3-1/2	3-1/2	3-1/4	1/2	6.50
ATTT-6362		3	4	3-15/16	4-3/8	5/8	9.70
ATTT-6363		3-1/2	4-3/8	4	4-3/8	5/8	11.75
ATTT-6449	4	1-1/4	3	3-3/4	3-1/4	1/2	4.50
ATTT-6453		1-1/2	3-1/8	3-13/16	3-1/4	1/2	5.55
ATTT-6458		2	3-1/2	3-3/4	3-1/4	1/2	5.55
ATTT-6460		2-1/2	3-1/2	3-7/8	3-1/4	1/2	6.05
ATTT-6462		3	4	4-1/8	4-1/2	5/8	10.95
ATTT-6463		3-1/2	4-1/4	4-1/8	4-1/2	5/8	9.25
ATTT-6464		4	4-1/2	4-1/8	4-1/2	5/8	13.50
ATTT-6758	5	2	3-1/2	4-7/16	3-1/2	1/2	7.35
ATTT-6760		2-1/2	3-1/2	4-11/16	3-1/2	1/2	8.80
ATTT-6762		3	4-3/8	4-3/4	6-3/4	5/8	22.75
ATTT-6763		3-1/2	4-3/8	4-3/4	6-3/4	5/8	21.60
ATTT-6764		4	4-1/2	4-9/16	6-3/4	5/8	22.45
ATTT-6767		5	6-3/4	4-1/4	6-3/4	5/8	28.65
ATTT-6958	6	2	4	5	4	1/2	11.50
ATTT-6960		2-1/2	3-1/2	5-7/8	4-1/2	5/8	17.55
ATTT-6962		3	4	5-1/4	4	5/8	17.35
ATTT-6963		3-1/2	4	5-1/4	4	5/8	14.25
ATTT-6964		4	4-1/2	5-7/16	4-1/2	5/8	21.00
ATTT-6967		5	5	5-1/2	7	5/8	16.75
ATTT-6969		6	7	5-1/2	7	5/8	33.90

* Consult manufacturer for further details or unlisted applications.

ALUMINUM TEE CONNECTORS

TYPE ATT15

Bolted Angle

Pipe Main to Pipe Tap

Aluminum alloy angle tee for aluminum pipe main to aluminum pipe tap connections at 15°. Clamping bolts have hex-stops for one-wrench installation. Contact sealant is recommended.

Also available with 10° tap. Example: ATT10-5858

Also available in 30°, 45°, and others.

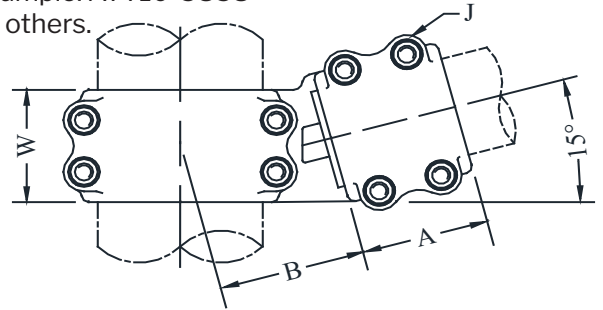

Casting Alloy: 356-T6 Aluminum
Clamping Hardware: Aluminum Alloy

CATALOG NUMBER	CONDUCTOR SIZE (NPS)		DIMENSIONS - INCHES				WEIGHT (POUNDS)
	PIPE MAIN	PIPE TAP	A	B	W	J	
ATT15-3930	1	3/4	2-3/8	2-3/8	3	1/2	2.60
ATT15-4930	1-1/4	3/4	2-3/8	2-7/8	3	1/2	2.75
ATT15-4939		1	3	2-7/8	3	1/2	2.95
ATT15-5330	1-1/2	3/4	3	2-7/8	3-1/2	1/2	2.85
ATT15-5339		1	3	2-7/8	3-1/2	1/2	3.05
ATT15-5349		1-1/4	3	2-7/8	3-1/2	1/2	4.20
ATT15-5353		1-1/2	3-1/8	2-7/8	3-1/8	1/2	3.45
ATT15-5839	2	1	3	2-7/8	3-1/2	1/2	3.40
ATT15-5849		1-1/4	3	2-7/8	3-1/2	1/2	3.65
ATT15-5853		1-1/2	3-1/4	1-9/16	3-3/4	1/2	4.55
ATT15-5858		2	3-1/2	3-1/16	3-1/2	1/2	4.45
ATT15-6049	2-1/2	1-1/4	2-3/4	1-3/4	2-3/4	1/2	3.55
ATT15-6053		1-1/2	3-1/8	3-1/8	3-1/2	1/2	4.45
ATT15-6058		2	3-1/2	3-7/16	3-1/2	1/2	5.20
ATT15-6060		2-1/2	3-1/2	1-7/8	3-1/2	5/8	4.35
ATT15-6253	3	1-1/2	3-1/8	3-5/8	3-1/2	1/2	5.05
ATT15-6258		2	3-1/2	3-1/2	3-1/2	1/2	6.05
ATT15-6260		2-1/2	3-1/2	3-13/16	3-1/2	1/2	6.05
ATT15-6262		3	4	4	4	5/8	9.65
ATT15-6358	3-1/2	2	3-1/2	4	3-1/4	1/2	5.75
ATT15-6360		2-1/2	3-1/2	4	3-1/4	1/2	6.30
ATT15-6362		3	4	4-5/8	4-1/2	5/8	10.20
ATT15-6458	4	2	3-1/2	4-1/4	3-1/4	1/2	5.80
ATT15-6460		2-1/2	3-1/2	4-1/4	3-1/4	1/2	6.30
ATT15-6462		3	4	4-11/16	4-1/2	5/8	8.90
ATT15-6464		4	4-1/2	4-11/16	4-1/2	5/8	14.00

* Consult manufacturer for further details or unlisted applications..

ALUMINUM TEE CONNECTORS

TYPE AVT15

Bolted Angle

Pipe Main to Two Pipe Tap

Aluminum alloy angle tee for aluminum pipe main to two aluminum pipe tap connections at 15°. Clamping bolts have hex-stops for one-wrench installation. Contact sealant is recommended. Also available with 10° tap. Example: AVT10-5858

Casting Alloy: 356-T6 Aluminum
Clamping Hardware: Aluminum Alloy

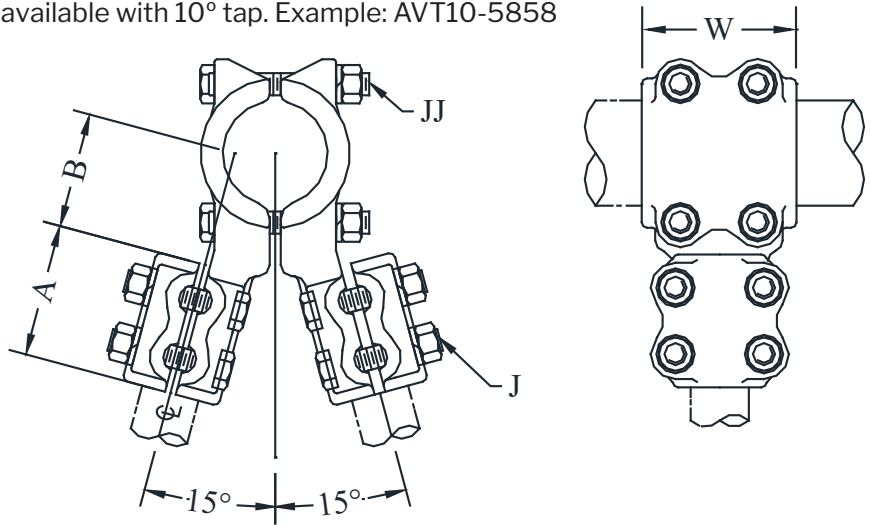

CATALOG NUMBER	CONDUCTOR SIZE (NPS)		DIMENSIONS - INCHES					WEIGHT (POUNDS)
	PIPE MAIN	PIPE TAP	A	B	W	J	JJ	
AVT15-3930	1	3/4	2-3/8	2	3	1/2	1/2	3.85
AVT15-3939		1	3	2	3	1/2	1/2	4.00
AVT15-4930	1-1/4	3/4	3	2-7/8	3-1/2	1/2	1/2	4.15
AVT15-4939		1	3	2-7/8	3-1/2	1/2	1/2	4.65
AVT15-5330	1-1/2	3/4	3	2-7/8	3-1/2	1/2	1/2	4.45
AVT15-5339		1	3	2-7/8	3-1/2	1/2	1/2	4.75
AVT15-5349		1-1/4	3	2-7/8	3-1/2	1/2	1/2	5.05
AVT15-5839	2	1	3	2-7/8	3-1/2	1/2	1/2	4.95
AVT15-5849		1-1/4	3	3	3-1/2	1/2	1/2	5.20
AVT15-5853		1-1/2	3	2-3/4	3-1/2	1/2	1/2	6.55
AVT15-6049	2-1/2	1-1/4	3	2-5/8	3-1/2	1/2	1/2	6.15
AVT15-6053		1-1/2	3-1/8	2-7/8	3-1/2	1/2	1/2	6.65
AVT15-6058		2	3-1/2	2-7/8	3-1/2	1/2	1/2	7.15
AVT15-6253	3	1-1/2	3-1/8	3-1/2	3-1/2	1/2	1/2	7.15
AVT15-6258		2	3-1/2	3-1/2	3-1/2	1/2	1/2	7.60
AVT15-6358	3-1/2	2	3-1/2	3-1/4	3-1/4	1/2	1/2	9.10
AVT15-6360		2-1/2	3-1/2	3-5/8	3-1/4	1/2	1/2	11.10
AVT15-6362		3	4	4-1/4	4	5/8	5/8	21.30
AVT15-6458	4	2	3-1/2	4-1/4	4	1/2	5/8	13.40
AVT15-6460		2-1/2	3-1/2	4-1/4	4-1/2	1/2	5/8	15.50
AVT15-6462		3	4	4-1/4	4	5/8	5/8	20.05

* Consult manufacturer for further details or unlisted applications.

ALUMINUM TEE CONNECTORS

TYPE AXTF

Bolted Expansion
Pipe Main to Pipe Tap

Aluminum alloy expansion tee for aluminum pipe connections. Clamping bolts have hex-stops for one-wrench installation. Contact sealant is recommended. Add suffix (H) to catalog number for SCH 80 pipe. Example: AXTF-6060H

Casting Alloy: 356-T6 Aluminum
Laminated Straps: 1100-0 Aluminum
Clamping Hardware: Aluminum Alloy

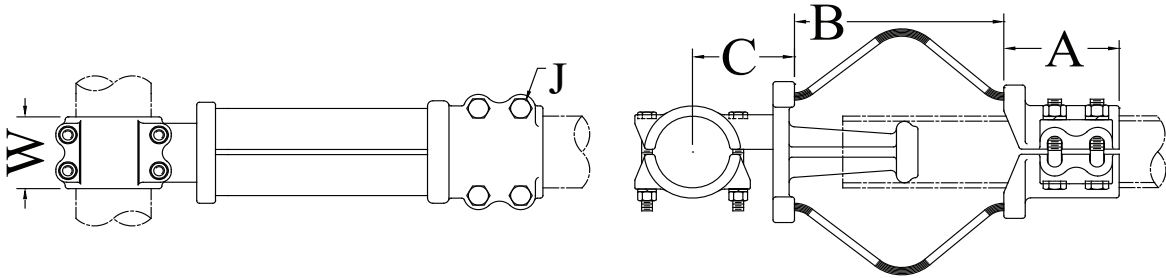

CATALOG NUMBER	CONDUCTOR SIZE (NPS)		DIMENSIONS - INCHES					WEIGHT (POUNDS)
	PIPE MAIN	PIPE TAP	A	B	C	W	J	
AXTF-5353	1-1/2	1-1/2	4-3/8	6-1/2	4-1/4	3-1/8	1/2	7.60
AXTF-5858	2	2	4-3/4	4	4-3/4	3-1/2	1/2	7.40
AXTF-6060	2-1/2	2-1/2	4-3/4	7-3/4	5-1/2	3-1/2	1/2	14.85
AXTF-6262	3	3	5-3/8	9-1/2	4-3/4	3-1/2	5/8	19.30
AXTF-6464	4	4	5-3/4	7	4-1/2	5-1/8	5/8	24.60

TYPE WYTI

Welded Angle
Pipe Main to Two Pipe Tap

Variety of "Y" connectors available
Contact manufacturer for further details or unlisted applications.

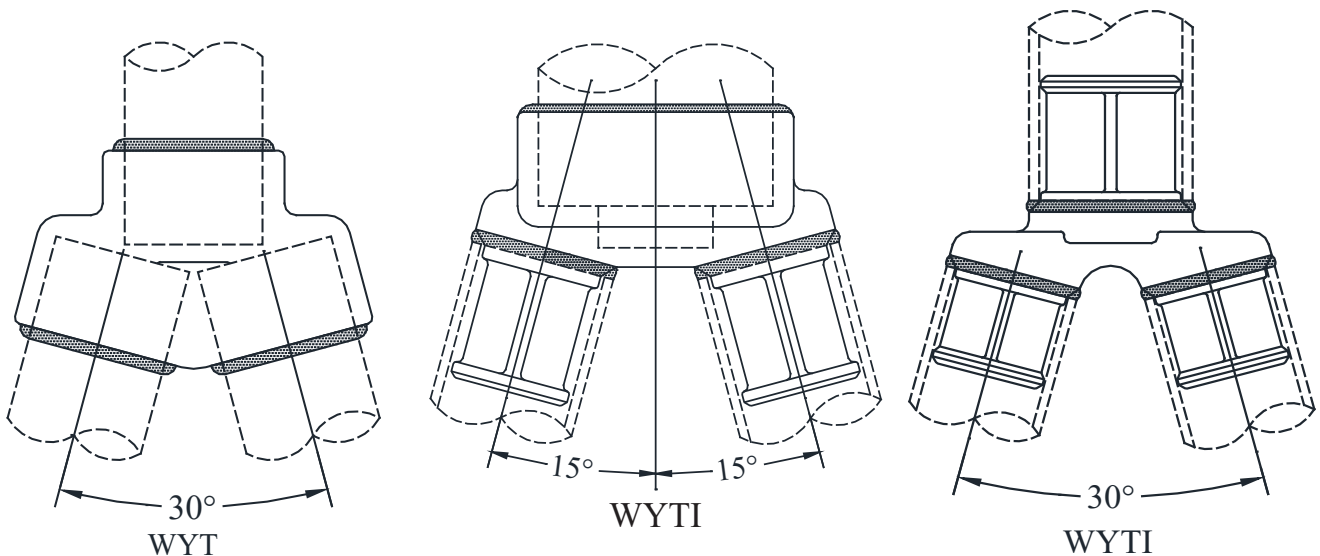

ALUMINUM TEE CONNECTORS

TYPE WFTT

Straight Weldment
Pipe Main to Pipe Tap

Aluminum alloy, straight weldment tee for aluminum pipe main to aluminum pipe tap connections.

Casting Alloy: 356-T6 Aluminum

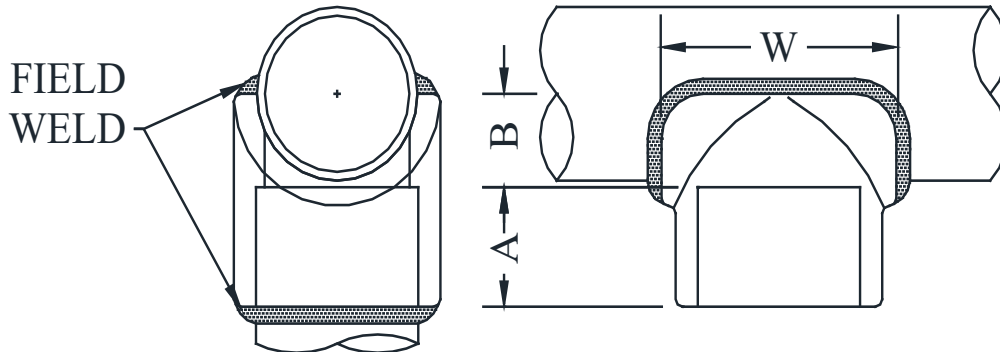

CATALOG NUMBER	CONDUCTOR SIZE (NPS)		DIMENSIONS - INCHES			WEIGHT (POUNDS)
	PIPE MAIN	PIPE TAP	A	B	W	
WFTT-3939	1	1	1-1/4	3/4	2-1/4	0.75
WFTT-4939	1-1/4	1	1-1/4	15/16	2-1/4	0.50
WFTT-4949		1-1/4	1-3/8	1	2-3/4	0.50
WFTT-5339	1-1/2	1	1-1/4	1-1/8	2-1/2	0.50
WFTT-5349		1-1/4	1	1-1/8	2-7/8	0.75
WFTT-5353		1-1/2	1-3/8	1-1/8	3	0.50
WFTT-5839	2	1	1-1/4	1-3/8	2-1/2	0.50
WFTT-5849		1-1/4	1	1-5/16	2-5/8	1.00
WFTT-5853		1-1/2	1-3/8	1-3/8	3-1/8	0.75
WFTT-5858		2	1-5/8	1-3/8	3-3/4	1.00
WFTT-6049	2-1/2	1-1/4	1	1-5/8	2-3/4	0.50
WFTT-6053		1-1/2	1-3/8	1-5/8	3-1/4	0.75
WFTT-6058		2	1-5/16	1-9/16	3-1/2	0.75
WFTT-6060		2-1/2	2	1-9/16	4-1/4	1.50
WFTT-6249	3	1-1/4	1-1/4	2	3	1.00
WFTT-6253		1-1/2	1-1/16	2-3/16	3-1/4	0.75
WFTT-6258		2	1-7/16	2-3/16	3-5/8	1.25
WFTT-6260		2-1/2	1-1/2	2-1/4	4-1/2	1.50
WFTT-6262		3	1-3/4	2	5	2.25
WFTT-6353	3-1/2	1-1/2	1-3/8	2-1/8	3	0.50
WFTT-6358		2	1-3/4	2-1/8	3-1/2	2.00
WFTT-6360		2-1/2	2	2-1/8	4-1/8	1.50
WFTT-6362		3	2-3/8	2-1/8	5-1/2	3.38
WFTT-6363		3-1/2	2-3/8	2-1/8	5-1/2	2.75

ALUMINUM TEE CONNECTORS

TYPE WFTT- Continued

CATALOG NUMBER	CONDUCTOR SIZE (NPS)		DIMENSIONS - INCHES			WEIGHT (POUNDS)
	PIPE MAIN	PIPE TAP	A	B	W	
WFTT-6453	4	1-1/2	1-3/4	2-3/8	4	1.55
WFTT-6458		2	1-3/4	2-3/8	4	1.25
WFTT-6460		2-1/2	2	2-1/2	4-1/4	2.00
WFTT-6462		3	2-1/2	2-3/8	5-1/4	2.25
WFTT-6463		3-1/2	2-1/2	2-3/4	6	2.75
WFTT-6464		4	2	2-3/4	6-1/4	4.75
WFTT-6760	5	2-1/2	2	3	4-1/4	3.00
WFTT-6762		3	2-1/2	3	5-1/8	3.00
WFTT-6764		4	2-7/32	3-9/32	6	4.00
WFTT-6767		5	2-1/2	3	7-3/4	7.00
WFTT-6960	6	2-1/2	1-7/8	3-3/4	4-1/2	1.50
WFTT-6962		3	2-1/2	3-1/2	4-7/8	3.00
WFTT-6963		3-1/2	2-3/8	3-1/2	5-1/4	2.50
WFTT-6964		4	2-1/2	3-9/16	6	4.75
WFTT-6967		5	3-15/16	3-7/16	7-1/2	7.00
WFTT-6969		6	3	3-5/8	8-1/4	8.00

*Consult manufacturer for further details or unlisted applications.

ALUMINUM TEE CONNECTORS

TYPE WFTT15

Angle Weldment

Pipe Main to Pipe Tap

Aluminum alloy, angle weldment, tee for connecting aluminum pipe to aluminum pipe tap at 15°.

For 10° tap angles use WFTT10.

Taps at 30°, 45°, & others available upon request.

Casting Alloy: 356-T6 Aluminum

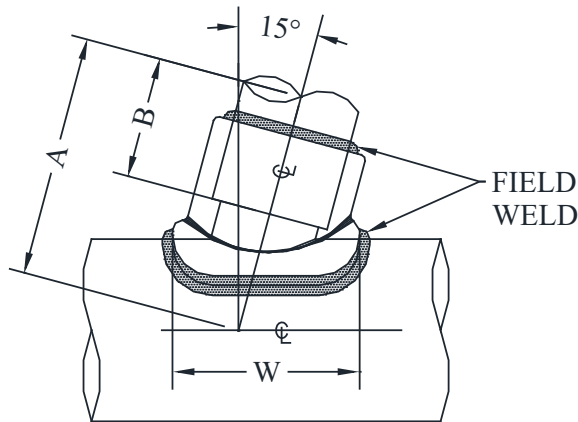

CATALOG NUMBER	CONDUCTOR SIZE (NPS)		DIMENSIONS - INCHES			WEIGHT (POUNDS)
	PIPE MAIN	PIPE TAP	A	B	W	
WFTT15-4939	1-1/4	1	2-1/2	1-1/4	2-13/16	0.85
WFTT15-4949		1-1/4	2-1/2	1-1/4	2-13/16	0.75
WFTT15-5339	1-1/2	1	2-3/4	1-1/4	3	0.75
WFTT15-5349		1-1/4	2-3/4	1-3/8	3	0.75
WFTT15-5353		1-1/2	2-3/4	1-3/8	3-3/8	0.75
WFTT15-5849	2	1-1/4	3-1/8	1-1/2	2-7/8	0.75
WFTT15-5853		1-1/2	3	1-7/16	3-3/8	0.75
WFTT15-5858		2	3-1/2	1-3/4	4-1/8	1.50
WFTT15-6049	2-1/2	1-1/4	3-1/16	1-1/4	2-3/4	1.00
WFTT15-6053		1-1/2	3-7/16	1-1/2	3-1/4	1.05
WFTT15-6058		2	3-3/4	1-3/4	3-7/8	2.00
WFTT15-6060		2-1/2	4-1/16	2	4-5/16	1.75
WFTT15-6249	3	1-1/4	3-9/16	1-1/2	3	1.00
WFTT15-6253		1-1/2	3-9/16	1-1/2	3-5/16	1.00
WFTT15-6258		2	4	1-3/4	3-15/16	1.05
WFTT15-6260		2-1/2	4-5/16	2	4-1/2	1.75
WFTT15-6262		3	5	2-1/2	5-3/8	2.55
WFTT15-6353	3-1/2	1-1/2	3-7/8	1-13/16	3-5/8	1.25
WFTT15-6358		2	4-5/16	1-3/4	3-3/4	1.25
WFTT15-6360		2-1/2	4-1/2	2	4-7/16	1.50
WFTT15-6362		3	5-1/4	2-1/2	5-1/4	3.00
WFTT15-6363		3-1/2	5-3/8	2-1/2	6-1/16	4.00

Continued on next page

ALUMINUM TEE CONNECTORS

TYPE WFTT15- Continued

CATALOG NUMBER	CONDUCTOR SIZE (NPS)		DIMENSIONS - INCHES			WEIGHT (POUNDS)
	PIPE MAIN	PIPE TAP	A	B	W	
WFTT15-6458	4	2	4-1/2	1-3/4	3-11/16	1.23
WFTT15-6460		2-1/2	5	2	4-5/8	2.25
WFTT15-6462		3	5-1/2	2-1/2	5-3/4	3.25
WFTT15-6463		3-1/2	5-9/16	2-1/2	6	3.00
WFTT15-6464		4	6-3/4	3	6-5/8	5.25
WFTT15-6760	5	2-1/2	5-1/2	2	4-7/8	2.25
WFTT15-6762		3	6-1/16	2-3/8	5-1/2	3.50
WFTT15-6764		4	6-3/4	3	6-3/8	5.00
WFTT15-6767		5	7	3	7-3/4	7.00
WFTT15-6962	6	3	6-9/16	2-1/2	5-3/8	3.25
WFTT15-6963		3-1/2	6-5/8	2-1/2	5-7/8	3.75
WFTT15-6964		4	7-1/4	3	6-1/2	5.00
WFTT15-6967		5	7	2-1/2	7-7/8	10.10
WFTT15-6969		6	7-3/4	3	9-1/8	10.25

* Consult manufacturer for further details or unlisted applications.

ALUMINUM TEE CONNECTORS

TYPE WFVT15

Angle Weldment

Pipe Main to Two Pipe Taps

Casting Alloy: 356-T6 Aluminum

Aluminum alloy, angle weldment tee for aluminum pipe main to two aluminum pipe tap connection at 15°.
For 10° tap angles use WFVT10.

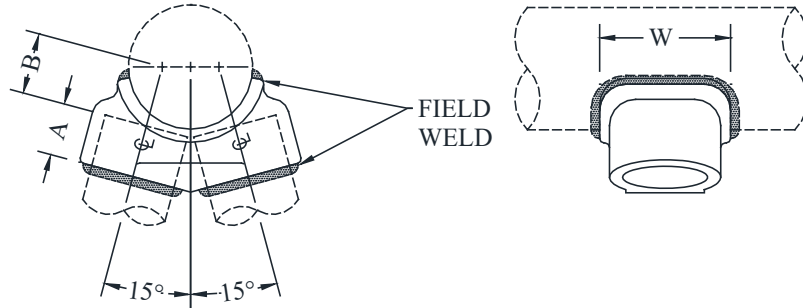

CATALOG NUMBER	CONDUCTOR RANGE (NPS)		DIMENSIONS - INCHES			WEIGHT (POUNDS)
	PIPE MAIN	PIPE TAP	A	B	W	
WFVT15-4939	1-1/4	1	1-1/2	1-1/4	2-3/4	1.85
WFVT15-4949		1-1/4	1-3/8	1-1/4	2-3/4	1.50
WFVT15-5339	1-1/2	1	1-1/8	1-1/4	2-3/4	1.00
WFVT15-5349		1-1/4	1-1/2	1-1/4	2-3/4	1.25
WFVT15-5353		1-1/2	1-3/8	1-1/4	3-1/4	2.00
WFVT15-5849	2	1-1/4	1-1/2	1-1/4	2-3/4	1.00
WFVT15-5853		1-1/2	1-3/8	1-1/4	3-1/4	1.50
WFVT15-5858		2	1-3/4	1-1/8	3-3/4	2.50
WFVT15-6049	2-1/2	1-1/4	1-1/2	1-1/2	2-3/4	1.25
WFVT15-6053		1-1/2	1-3/8	1-7/16	3-1/4	1.50
WFVT15-6058		2	1-3/4	1-3/4	4	3.00
WFVT15-6060		2-1/2	2	1-5/16	4-1/2	3.00
WFVT15-6249	3	1-1/4	1-1/2	1-3/4	3-1/2	1.50
WFVT15-6253		1-1/2	1-3/8	1-13/16	3-1/4	1.50
WFVT15-6258		2	1-1/2	1-3/4	3-3/4	2.00
WFVT15-6260		2-1/2	2	1-5/8	4-1/4	3.50
WFVT15-6262		3	2-1/2	1-9/16	5-1/4	6.50
WFVT15-6353	3-1/2	1-1/2	1-3/8	2-1/16	3-1/4	2.25
WFVT15-6358		2	1-3/4	2-1/2	4	2.50
WFVT15-6360		2-1/2	2	2-3/8	4-1/4	3.75
WFVT15-6363		3-1/2	2-1/2	2-1/4	5-3/4	8.00
WFVT15-6458	4	2	1-3/4	2-5/8	4	2.25
WFVT15-6460		2-1/2	2	2-1/4	4-1/4	4.00
WFVT15-6462		3	2-1/2	2-1/8	5-1/4	5.50
WFVT15-6463		3 1/2	2-1/2	2	5-3/4	6.75
WFVT15-6464		4	3	2-5/8	6-1/4	12.50
WFVT15-6760	5	2-1/2	2	2-13/16	4-1/2	4.00
WFVT15-6762		3	2-1/2	2-11/16	4-3/4	6.00
WFVT15-6764		4	3	2-3/4	6-1/2	12.20
WFVT15-6767		5	3	3	8	16.75
WFVT15-6962	6	3	2-1/2	3-1/2	5-3/8	7.00
WFVT15-6963		3-1/2	2-1/2	3-1/4	5-3/4	7.50
WFVT15-6964		4	3	3-3/16	6-1/4	10.00
WFVT15-6967		5	3	3-3/8	8-1/4	15.00
WFVT15-6969		6	3	3-3/8	8-3/4	22.50

*Consult manufacturer for further details or unlisted applications.

SEFCOR

Return To Index

ALUMINUM TEE CONNECTORS

TYPE WTC

Straight Weldment
Pipe Main to Cable Tap

Aluminum alloy, straight weldment, tee for aluminum pipe main to cable tap connections.

Casting Alloy: 356-T6 Aluminum

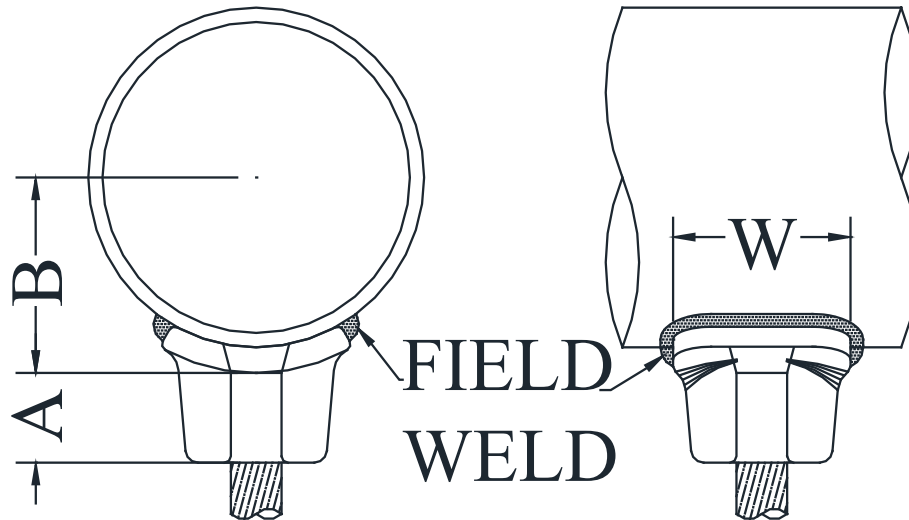

CATALOG NUMBER	CONDUCTOR RANGE			DIMENSIONS - INCHES			WEIGHT (POUNDS)
	PIPE MAIN	AAC TAP	ACSR TAP	A	B	W	
WTC-4916	1-1/4	336 MCM	----	1-1/16	1-3/16	2	0.25
WTC-5816	2	336.4 - 350 MCM	266 MCM	1-1/4	1-3/4	2-3/8	0.75
WTC-5821		550 - 556 MCM	----	1-1/4	1-3/4	2-3/8	0.75
WTC-6016	2-1/2	336.4 - 350 MCM	----	1-1/16	1-13/16	2-1/2	2.00
WTC-6029		795 MCM	----	1-1/16	1-13/16	2-1/2	2.00
WTC-6221	3	550 - 556 MCM	----	1-1/4	1-3/4	2-3/8	0.75
WTC-6239		1250 - 1300 MCM	1113 MCM	1-1/8	2-1/16	2-1/2	0.75
WTC-6252		2500 MCM	----	2-9/16	2-3/16	4	0.75
WTC-6329	3-1/2	795 MCM	636 MCM	1-1/2	2	2-1/2	1.50
WTC-6337		1113 MCM	1033.5 MCM	1-1/2	2-3/8	2-3/4	2.00
WTC-6341		1431 MCM	1272 MCM	1-1/2	2-3/8	2-3/4	0.75
WTC-6433	4	954 MCM	715 - 795 MCM	1-1/4	2-3/4	2-3/4	1.25
WTC-6439		1250 - 1300 MCM	----	1-5/8	2-3/4	3	1.50
WTC-6446		1796 MCM	1590 MCM	2-1/4	2-3/4	3-3/4	3.05
WTC-6729	5	750 - 795 MCM	636 - 666 MCM	1-1/2	3	3-1/4	0.75
WTC-6746		----	1590 MCM	1-5/8	3-1/8	3-1/4	1.00
WTC-6752		2500 MCM	----	1-13/16	3-5/16	3-1/2	1.50
WTC-6952	6	2500 MCM	----	1-3/4	3-13/16	3-1/2	1.25

ALUMINUM TEE CONNECTORS

TYPE WTF

Weldment Tee
Pipe Main to Flat Pad

Aluminum alloy weldment, range taking tee, for connecting aluminum pipe main to flat pad. NEMA hole drilling is standard. Contact sealant is recommended on pad after welding. Pad is finished on both sides.
NOTE: Not intended for full current application.

Casting Alloy: 356-T6 Aluminum

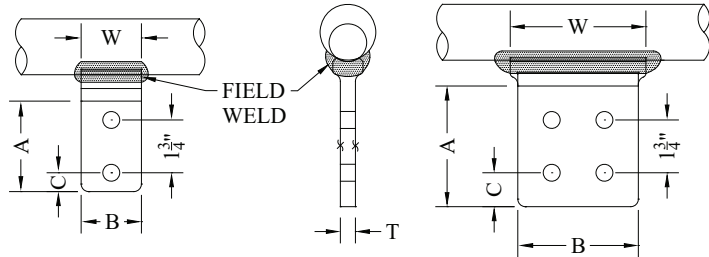

FIG. 1

FIG. 2

CATALOG NUMBER	FIG. NO.	PIPE SIZE	DIMENSIONS - INCHES					WEIGHT (POUNDS)
			A	B	C	T	W	
WTF-3960-2B	1	1" - 2-1/2" NPS	3	2	5/8	13/16	2	0.85
WTF-3960-4A	2		3	3	5/8	13/16	3	1.30
WTF-3960-4B	2		4	4	1-1/8	1/2	4-1/2	1.00
WTF-6269-2B	1	3" - 6" NPS	3	2	5/8	3/4	2-1/2	0.75
WTF-6269-4A	2		3	3	5/8	3/4	3-1/2	1.00
WTF-6269-4B	2		4	4	1-1/8	3/4	5	1.70

TYPE WTFR

Weldment Tee
Pipe Main to Flat Pad
90° Transverse Pad

Aluminum alloy weldment, range taking tee, for connecting aluminum pipe main to flat pad. NEMA hole drilling is standard. Contact sealant is recommended on pad after welding. Pad is finished on both sides.
NOTE: Not intended for full current application. See page 86 for full current fittings.

Casting Alloy: 356-T6 Aluminum

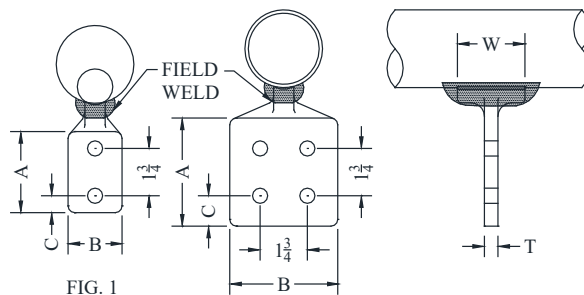

FIG. 1

FIG. 2

CATALOG NUMBER	FIG. NO.	PIPE SIZE	DIMENSIONS - INCHES					WEIGHT (POUNDS)
			A	B	C	T	W	
WTFR-3960-2B	1	1" - 2-1/2" NPS	3	2	5/8	3/4	2-3/4	0.50
WTFR-3960-4A	2		3	3	5/8	3/4	2-3/4	1.00
WTFR-3960-4B	2		4	4	1-1/8	1/2	2-1/2	1.25
WTFR-6269-2B	1	3" - 6" NPS	3	2	5/8	3/4	1-1/4	1.00
WTFR-6269-4A	2		3	3	5/8	3/4	3	1.00
WTFR-6269-4B	2		4	4	1-1/8	3/4	4	1.35

BRONZE TEE CONNECTORS

TYPE ATT15-BR

Bolted Angle
Pipe Main to Pipe Tap

Bronze alloy angle tee copper pipe main to copper pipe tap connections. Clamping bolts have hex-stops for one-wrench installation. Also available with 10° tap. Example: ATT10-5858-BR

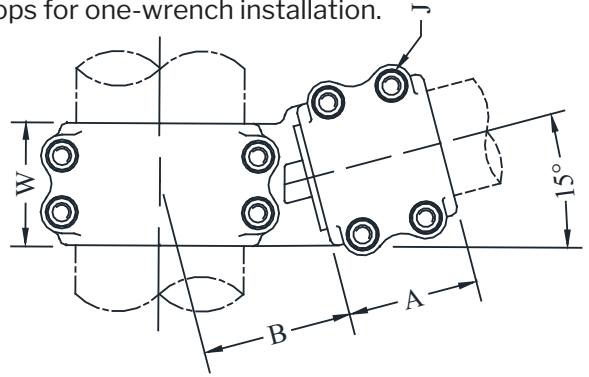

Casting Alloy: Electrical Bronze
Clamping Hardware: Silicon Bronze

CATALOG NUMBER	CONDUCTOR SIZE (NPS)		DIMENSIONS - INCHES				WEIGHT (POUNDS)
	PIPE MAIN	PIPE TAP	A	B	W	J	
ATT15-3930-BR	1	3/4	2-3/8	2-3/8	3	1/2	8.25
ATT15-4930-BR	1-1/4	3/4	2-3/8	2-5/8	3	1/2	10.65
ATT15-4939-BR		1	3	2-7/8	3	1/2	9.90
ATT15-5330-BR	1-1/2	3/4	3	2-7/8	3-1/8	1/2	9.60
ATT15-5339-BR		1	3	2-7/8	3-1/8	1/2	9.85
ATT15-5349-BR		1-1/4	3	2-7/8	3-1/8	1/2	10.10
ATT15-5353-BR		1-1/4	3-1/8	2-7/8	3-1/8	1/2	10.35
ATT15-5839-BR	2	1	3	2-7/8	3-1/2	1/2	10.85
ATT15-5849-BR		1-1/4	3	2-7/8	3-1/2	1/2	12.70
ATT15-5853-BR		1-1/2	3-1/4	1-9/16	3-3/4	1/2	14.50
ATT15-5858-BR		2	3-1/2	3-1/16	3-1/2	1/2	13.45
ATT15-6049-BR	2-1/2	1-1/4	3-1/2	1	2-3/4	1/2	14.50
ATT15-6053-BR		1-1/2	3-1/2	3-1/8	2-3/4	1/2	14.00
ATT15-6058-BR		2	3-1/2	3-3/16	3-1/2	1/2	15.10
ATT15-6060-BR		2-1/2	3-1/2	1-7/8	3-1/2	5/8	12.75
ATT15-6253-BR	3	1-1/2	3-1/8	3-5/8	3-1/2	1/2	18.05
ATT15-6258-BR		2	3-1/2	3-1/2	3-1/2	1/2	19.35
ATT15-6260-BR		2-1/2	3-1/2	3-13/16	3-1/2	1/2	19.40
ATT15-6262-BR		3	4	4	4	5/8	31.00
ATT15-6358-BR	3-1/2	2	3-1/2	4	3-1/4	1/2	17.85
ATT15-6360-BR		2-1/2	3-1/2	4	3-1/4	1/2	20.65
ATT15-6362-BR		3	4	4-5/8	3-1/2	5/8	33.70
ATT15-6458-BR	4	2	3-1/2	4-1/4	3-1/4	1/2	16.90
ATT15-6460-BR		2-1/2	3-1/2	4-1/4	3-1/4	1/2	18.55
ATT15-6462-BR		3	4	4-5/16	4-1/2	5/8	28.25

* Consult manufacturer for further details or unlisted applications.

BRONZE TEE CONNECTORS

TYPE AVT15-BR

Bolted Angle

Pipe Main to Two Pipe Tap

Bronze alloy angle tee for connecting copper pipe main to two copper pipe taps at 15°. Clamping bolts have hex-stops for one-wrench installation.

Also available with two 10° tap. Example: AVT10-5858-BR

Casting Alloy: Electrical Bronze

Clamping Hardware: Silicon Bronze

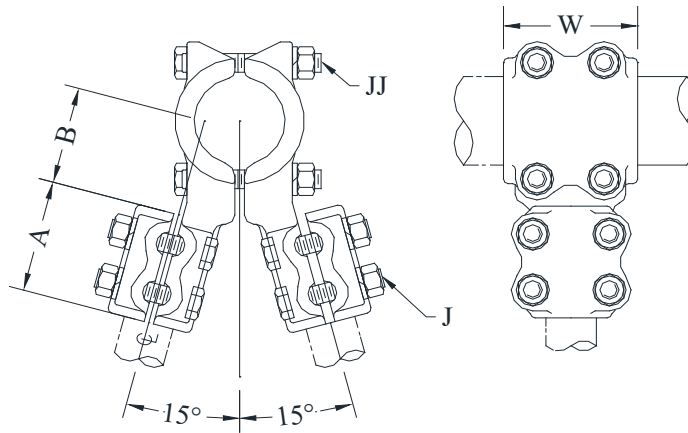

CATALOG NUMBER	CONDUCTOR SIZE (NPS)		DIMENSIONS - INCHES					WEIGHT (POUNDS)
	PIPE MAIN	PIPE TAP	A	B	W	J	JJ	
AVT15-3930-BR	1	3/4	2-3/8	2-7/16	3	1/2	1/2	12.35
AVT15-4930-BR	1-1/4	3/4	2-3/8	2-11/16	3	1/2	1/2	15.70
AVT15-4939-BR		1	3	2-7/8	3-1/2	1/2	1/2	13.55
AVT15-5330-BR	1-1/2	3/4	3	2-7/8	3-1/2	1/2	1/2	15.00
AVT15-5339-BR		1	3	2-7/8	3-1/2	1/2	1/2	15.65
AVT15-5349-BR		1-1/4	3	2-7/8	3-1/2	1/2	1/2	17.30
AVT15-5839-BR	2	1	3	2-7/8	3-1/2	1/2	1/2	15.80
AVT15-5849-BR		1-1/4	3	3	3-1/2	1/2	1/2	17.20
AVT15-5853-BR		1-1/2	3-1/8	2-5/8	3-1/2	1/2	1/2	20.40
AVT15-5858-BR		2	3-1/2	3	3-1/2	1/2	1/2	21.10
AVT15-6049-BR	2-1/2	1-1/4	3	2-5/8	3-1/2	1/2	1/2	19.25
AVT15-6053-BR		1-1/2	3-1/8	2-5/8	3-1/2	1/2	1/2	20.55
AVT15-6058-BR		2	3-1/2	2-7/8	3-1/2	1/2	1/2	23.70
AVT15-6253-BR	3	1-1/2	3-1/8	3-1/2	3-1/2	1/2	1/2	22.50
AVT15-6258-BR		2	3-1/2	3-1/2	3-1/2	1/2	1/2	24.40
AVT15-6260-BR		2-1/2	3-1/2	3-5/8	3-1/2	1/2	1/2	27.70
AVT15-6358-BR	3-1/2	2	3-1/2	3-1/4	3-1/4	1/2	1/2	29.25
AVT15-6360-BR		2-1/2	3-1/2	3-5/8	3-1/4	1/2	1/2	35.90
AVT15-6362-BR		3	4	4-1/4	4	5/8	5/8	47.25
AVT15-6458-BR	4	2	3-1/2	4-3/16	4	1/2	5/8	33.80
AVT15-6460-BR		2-1/2	3-1/2	4-1/4	4-1/2	1/2	5/8	40.60
AVT15-6462-BR		3	4	4-1/4	4	5/8	5/8	48.20

* Consult manufacturer for further details or unlisted applications.

SEFCOR

Return To Index

BRONZE TEE CONNECTORS

TYPE TCRCT

Straight Bolted
Cable Main to Cable Tap

Bronze alloy tee for connecting copper cable main to copper cable tap connections. Clamping bolts have hex-stops for one wrench installation. All sizes furnished with reversible cable caps. 1/2" clamping available upon request.

Casting Alloy: Electrical Bronze
Clamping Hardware: Silicon Bronze

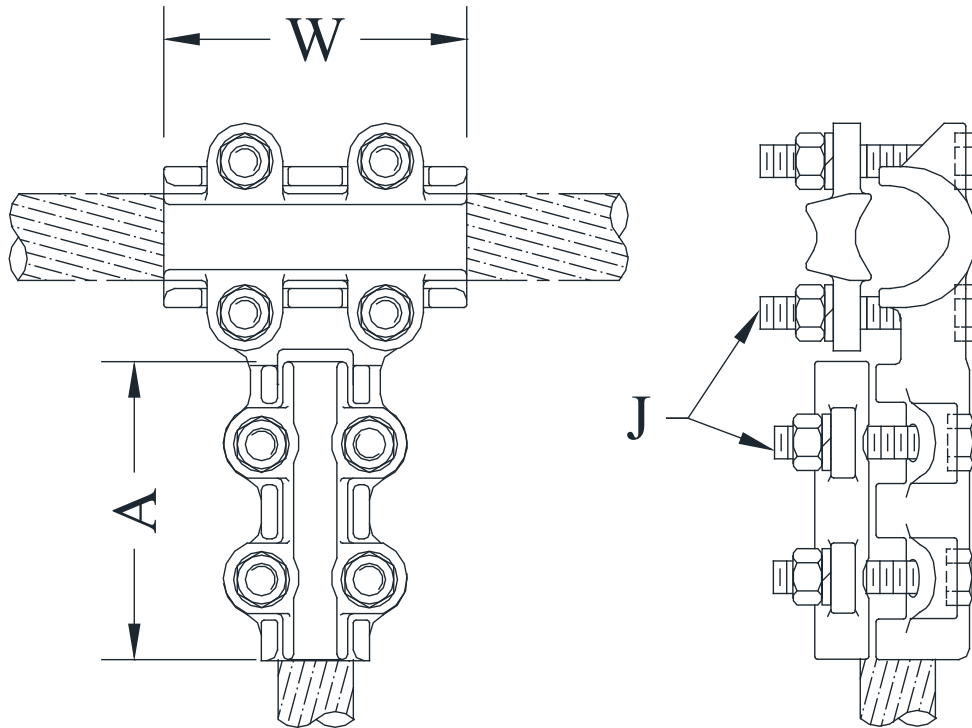

CATALOG NUMBER	CONDUCTOR RANGE				DIMENSIONS - INCHES			WEIGHT (POUNDS)
	CABLE MAIN		CABLE TAP		A	W	J	
	CABLE	DIA.	CABLE	DIA.				
TCRCT-1111	#6 - 4/0 MCM	.162 - .528	#6 - 4/0 MCM	.162 - .528	3-1/4	3-1/4	3/8	2.10
TCRCT-1414	#4 - 300 MCM	.232 - .630	#4 - 300 MCM	.232 - .630	3-1/4	3-1/4	3/8	2.95
TCRCT-2014	1/0 - 500 MCM	.369 - .814	#4 - 300 MCM	.232 - .630	3-1/4	3-9/16	3/8	3.25
TCRCT-2020			1/0 - 500 MCM	.369 - .814	3-7/16	3-7/16	3/8	3.85
TCRCT-3414	4/0 - 1000 MCM	.522 - 1.152	#4 - 300 MCM	.232 - .630	3-1/4	3-1/2	3/8	4.00
TCRCT-3420			1/0 - 500 MCM	.369 - .814	3-7/16	3-1/2	3/8	4.00
TCRCT-3434			4/0 - 1000 MCM	.522 - 1.152	3-1/2	3-1/2	1/2	6.40
TCRCT-4820	1500 - 2000 MCM	1.412 - 1.631	1/0 - 500 MCM	.369 - .814	3-3/8	3-1/4	3/8	5.10
TCRCT-4848	500 - 2000 MCM	.814 - 1.631	500 - 2000 MCM	.814 - 1.631	5	5	1/2	11.80

BRONZE TEE CONNECTORS

TYPE TFC

Straight Bolted
Cable Main to Flat Pad Tap

Bronze alloy tee for copper cable to flat pad.
NEMA hole drilling is standard.
Clamping bolts have hex-stops for one-wrench installation.

Casting Alloy: Electrical Bronze
Clamping Hardware: Silicon Bronze

Also available for two cables to flat bar. Example: TFC2-14-2B

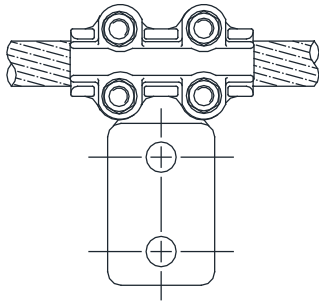

FIG. 1

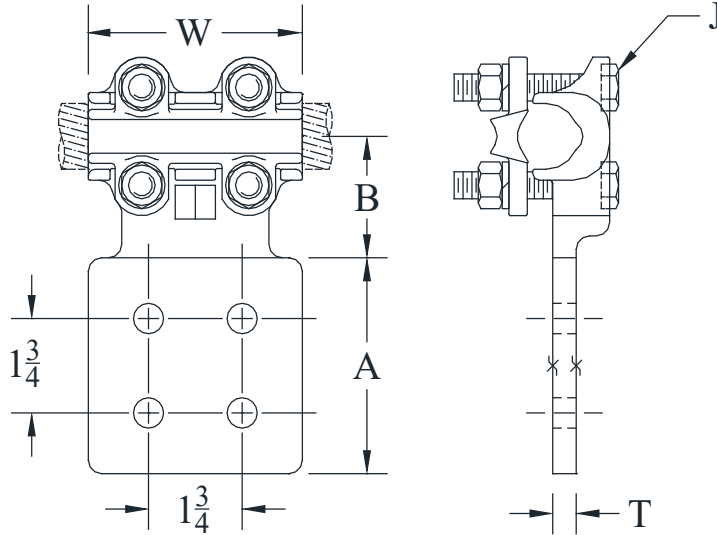

FIG. 2

CATALOG NUMBER	FIG. NO.	CONDUCTOR RANGE	PAD WIDTH	DIMENSIONS - INCHES					WEIGHT (POUNDS)
				A	B	W	T	J	
TFC-14-2B	1	#4 - 300 MCM	2	3	1-1/4	3-1/4	5/16	3/8	2.85
TFC-14-4A	2		3	3	1-1/4	3-1/4	5/16	3/8	2.85
TFC-14-4B	2		4	4	1-3/8	3-1/4	5/16	3/8	3.85
TFC-20-2B	1	1/0 - 500 MCM	2	3-1/8	1-1/8	3-7/16	7/16	3/8	2.55
TFC-20-4A	2		3	3	1-1/2	2-3/4	3/8	1/2	3.50
TFC-20-4B	2		4	4	1-5/8	2-3/4	3/8	1/2	4.00
TFC-34-2B	1	4/0 - 1000 MCM	2	3	2-5/32	3-1/2	3/8	1/2	6.10
TFC-34-4A	2		3	3	2-5/32	3-1/2	3/8	1/2	6.10
TFC-34-4B	2		4	4	2-1/4	4	7/16	1/2	6.75

BRONZE TEE CONNECTORS

TYPE TFT

Straight Bolted
Pipe Main to Flat Pad Tap

Bronze alloy tee for connecting copper pipe main to flat pads.
NEMA hole drilling is standard.
Clamping bolts have hex-stops for one-wrench installation.

Casting Alloy: Electrical Bronze
Clamping Hardware: Silicon Bronze

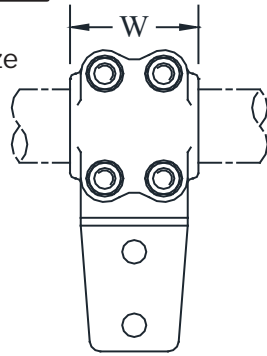

FIG. 1

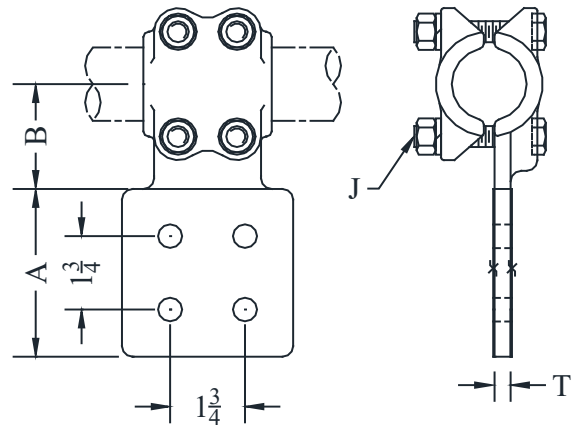

FIG. 2

CATALOG NUMBER	CONDUCTOR SIZE		DIMENSIONS - INCHES					WEIGHT (POUNDS)
	PIPE MAIN (NPS)	PAD WIDTH	A	B	W	T	J	
TFT-30-2B	3/4	2	3	1-7/8	2-3/8	3/8	1/2	4.50
TFT-30-4A		3	3	1-7/8	2-3/8	3/8	1/2	5.75
TFT-30-4B		4	4	2-1/4	4	7/16	1/2	6.75
TFT-39-2B	1	2	3	2	3	1/2	1/2	5.75
TFT-39-4A		3	3-3/8	1-3/4	3	1/2	1/2	5.85
TFT-39-4B		4	4-3/8	1-3/4	3	1/2	1/2	6.40
TFT-49-2B	1-1/4	2	3	2-3/8	3	9/16	1/2	6.60
TFT-49-4A		3	3	2-3/8	3	9/16	1/2	6.60
TFT-49-4B		4	4	2-1/2	3	3/8	1/2	6.60
TFT-53-2B	1-1/2	2	3	2-5/8	3	7/16	1/2	7.90
TFT-53-4A		3	3	2-5/8	3	7/16	1/2	7.90
TFT-53-4B		4	4	2-1/4	3	1/2	1/2	8.15
TFT-58-2B	2	2	3	2-3/4	3-1/2	5/8	1/2	10.70
TFT-58-4A		3	3	2-3/4	3-1/2	9/16	1/2	8.35
TFT-58-4B		4	4	2-3/4	3-1/2	7/16	1/2	9.50
TFT-60-2B	2-1/2	2	3	3-1/4	3-1/2	1/2	1/2	9.85
TFT-60-4A		3	3	3-1/4	3-1/2	1/2	1/2	9.85
TFT-60-4B		4	4	3-1/4	3-1/2	1/2	1/2	9.85
TFT-62-2B	3	2	3	3-3/8	3-1/2	1	1/2	10.35
TFT-62-4A		3	3	3-3/8	3-1/2	3/4	1/2	10.45
TFT-62-4B		4	4	3-1/4	3-1/2	3/4	1/2	13.45

Continued on next page

BRONZE TEE CONNECTORS

TYPE TFT- Continued

CATALOG NUMBER	CONDUCTOR SIZE		DIMENSIONS - INCHES					WEIGHT (POUNDS)
	PIPE MAIN (NPS)	PAD WIDTH	A	B	W	T	J	
TFT-63-2B	3-1/2	2	3	4-1/16	4-1/2	5/8	5/8	16.75
TFT-63-4A		3	3	3-5/8	3-1/4	3/4	1/2	16.75
TFT-63-4B		4	4	4-1/16	4-1/2	5/8	5/8	16.75
TFT-64-2B	4	2	3	3-3/4	3-1/4	3/4	5/8	26.05
TFT-64-4A		3	3	4-1/2	4-1/2	3/4	5/8	26.05
TFT-64-4B		4	4	4-1/2	4-1/2	3/4	5/8	26.05
TFT-67-2B	5	2	3	5-3/8	4-3/4	1	5/8	37.20
TFT-67-4A		3	3	5-3/8	4-3/4	1	5/8	37.70
TFT-67-4B		4	4	5-3/8	4-3/4	1	5/8	38.80
TFT-69-2B	6	2	3	5-1/2	7	1-1/8	5/8	50.45
TFT-69-4A		3	3	5-1/2	7	1-1/8	5/8	51.00
TFT-69-4B		4	4	5-1/2	7	1-1/8	5/8	52.25

BRONZE TEE CONNECTORS

TYPE TTRCT

Straight Bolted
Pipe Main to Cable Tap

Bronze alloy tee for connecting copper pipe main to copper cable tap.
Clamping bolts have hex-stops for one-wrench installation.
1/2" clamping hardware available upon request.

Casting Alloy: Electrical Bronze
Clamping Hardware: Silicon Bronze

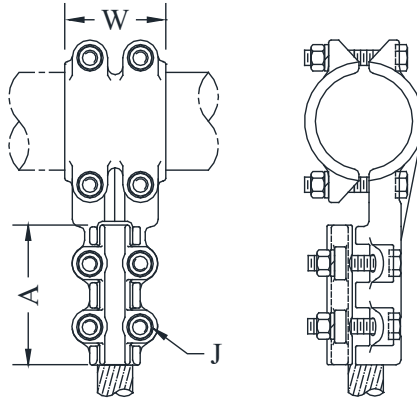

CATALOG NUMBER	CONDUCTOR SIZE		DIMENSIONS - INCHES				WEIGHT (POUNDS)
	PIPE MAIN (NPS)	CABLE TAP	A	W	J1	J2	
TTRCT-3014	3/4	#4W - 300 MCM	3-1/4	2-7/16	3/8	3/8	2.95
TTRCT-3020		1/0 - 500 MCM	3-3/8	2-3/8	3/8	3/8	3.05
TTRCT-3914	1	#4W - 300 MCM	3-1/4	2-1/2	3/8	3/8	3.50
TTRCT-3920		1/0 - 500 MCM	3-7/16	2	3/8	3/8	4.10
TTRCT-4914	1-1/4	#4W - 300 MCM	3-1/4	2-1/2	3/8	3/8	4.50
TTRCT-4920		1/0 - 500 MCM	3-1/2	2-1/2	3/8	3/8	5.25
TTRCT-5314	1-1/2	#4W - 300 MCM	3-1/4	2-9/16	3/8	3/8	4.20
TTRCT-5320		1/0 - 500 MCM	3-1/2	2-1/4	3/8	3/8	6.10
TTRCT-5334		4/0 - 1000 MCM	4	2-3/4	1/2	1/2	6.65
TTRCT-5814	2	#4W - 300 MCM	3-1/4	2-1/2	3/8	3/8	5.75
TTRCT-5820		1/0 - 500 MCM	3-1/2	2-1/2	3/8	3/8	5.55
TTRCT-5834		4/0 - 1000 MCM	3-1/2	3	1/2	1/2	7.00
TTRCT-6014	2-1/2	#4W - 300 MCM	3-5/8	3	1/2	1/2	7.90
TTRCT-6020		1/0 - 500 MCM	3-7/16	2-1/4	3/8	3/8	7.15
TTRCT-6034		4/0 - 1000 MCM	3-1/2	3	1/2	1/2	8.90
TTRCT-6220	3	1/0 - 500 MCM	3-1/2	3	1/2	1/2	10.75
TTRCT-6234		4/0 - 1000 MCM	3-1/2	3-1/2	1/2	1/2	11.95
TTRCT-6248		1000 - 2000 MCM	5	3	1/2	1/2	11.60
TTRCT-6320	3-1/2	1/0 - 500 MCM	3-1/2	3-1/4	1/2	1/2	14.35
TTRCT-6334		4/0 - 1000 MCM	3-1/2	3-1/4	1/2	1/2	16.20
TTRCT-6348		1500 - 2000 MCM	5	3-1/4	1/2	1/2	27.00
TTRCT-6420	4	1/0 - 500 MCM	3-7/16	3-1/4	1/2	3/8	14.55
TTRCT-6434		4/0 - 1000 MCM	4-1/4	3	1/2	1/2	11.60
TTRCT-6448		500 - 2000 MCM	5	4-1/2	1/2	1/2	13.00

BRONZE TEE CONNECTORS

TYPE TTT & TTHT

Straight Bolted
Pipe Main to Pipe Tap

Casting Alloy: Electrical Bronze
Clamping Hardware: Silicon Bronze

Bronze alloy tee for copper pipe main to copper pipe tap connections.
Clamping bolts have hex-stops for one-wrench installation.

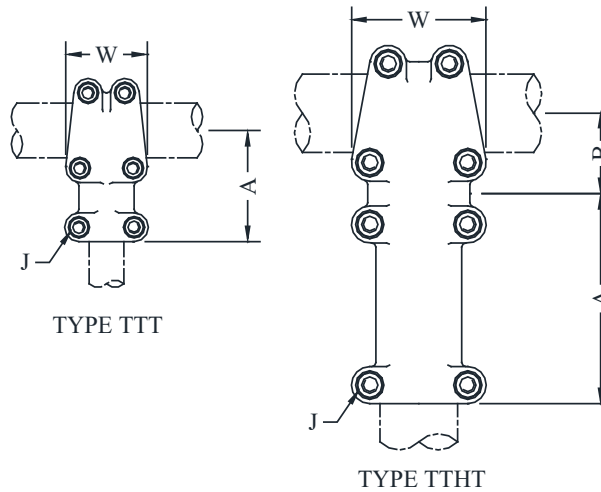

CATALOG NUMBER	CONDUCTOR SIZE (NPS)		DIMENSIONS - INCHES				WEIGHT (POUNDS)
	PIPE MAIN	PIPE TAP	A	B	W	J	
TTT-3030	3/4	3/4	2-7/8	----	2-7/16	3/8	2.10
TTT-3930	1	3/4	3-1/32	----	2-3/8	3/8	4.55
TTT-3939		1	3-3/16	----	2-11/16	3/8	3.60
TTT-4930	1-1/4	3/4	3-3/8	----	2-1/2	3/8	2.35
TTT-4939		1	3-1/4	----	2-9/16	3/8	2.40
TTT-4949		1-1/4	3-3/8	----	2-5/8	1/2	4.75
TTT-5339	1-1/2	1	3-1/2	----	2-9/16	3/8	5.15
TTT-5349		1-1/4	4-3/8	----	3-3/8	1/2	4.85
TTT-5353		1-1/2	4-1/4	----	3-5/8	1/2	6.60
TTHT-5849	2	1-1/4	4	2-9/16	3-3/8	1/2	8.95
TTHT-5853		1-1/2	5	2-13/16	4-1/8	1/2	10.50
TTHT-5858		2	6	2-13/16	4-1/8	1/2	12.10
TTHT-6039	2-1/2	1	5	2-7/8	4-5/8	1/2	10.75
TTHT-6049		1-1/4	5	2-7/8	3-3/8	1/2	11.40
TTHT-6058		2	6-3/4	2-3/4	3-3/8	1/2	11.30
TTHT-6060		2-1/2	3	3	3	1/2	11.35
TTHT-6258	3	2	7-5/16	2-1/16	3-1/4	1/2	15.00
TTHT-6262		3	4	3-3/4	4	5/8	25.00
TTHT-6462	4	3	8-7/16	2-5/8	5-1/4	5/8	26.75
TTHT-6463		3-1/2	4-1/2	4-1/16	4-1/2	5/8	29.30
TTHT-6464		4	4-1/2	4-1/16	4-1/2	5/8	31.30

*Consult manufacturer for further details or unlisted applications.

BRONZE TEE CONNECTORS

TYPE TDRCT

Straight Bolted

Two Cable Main to Cable Tap

Bronze Alloy Tee for (2) Copper Cable Mains to (1) Cable Tap.
Also available for double Main to double Tap; Type TDRDT

*Consult manufacturer for further details or unlisted applications.

Casting Alloy: Electrical Bronze
Clamping Hardware: Silicon Bronze

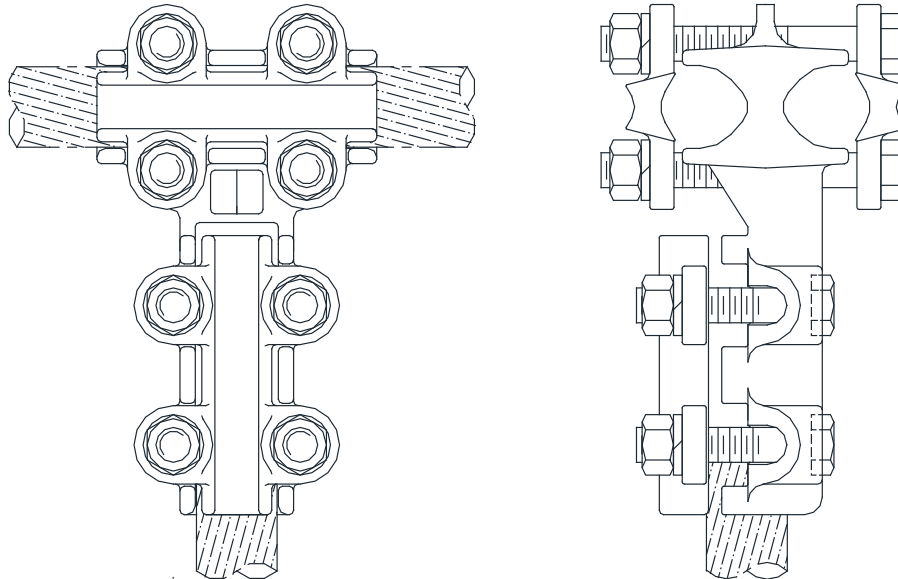

TYPE TTRDT

Straight Bolted

Pipe Main to (2) Cable Taps

Bronze Alloy Tee for Copper Pipe Main to (2) Copper Cable Taps.

*Consult manufacturer for further details or unlisted applications.

Casting Alloy: Electrical Bronze
Clamping Hardware: Silicon Bronze

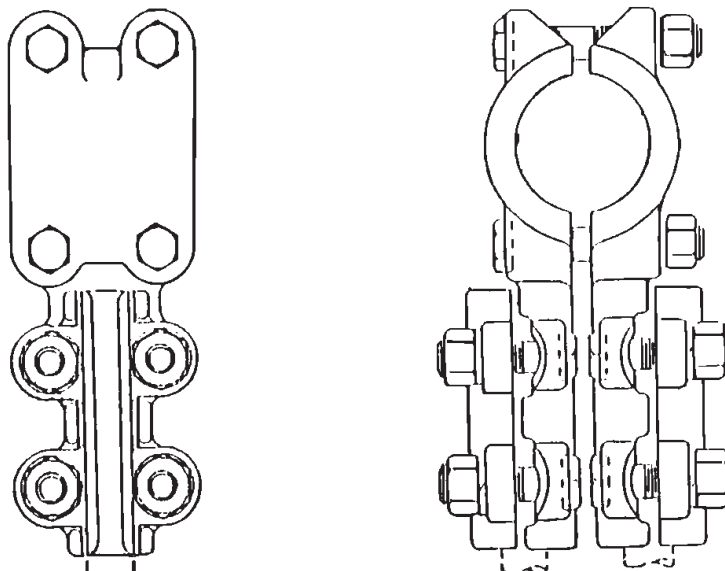

EHV TEE CONNECTORS

TYPE ACFHV

Bolted Straight
Cable Main to Flat Pad Tap

Casting Alloy: 356-T6 Aluminum
Clamping Hardware: Aluminum Alloy

ALUMINUM • 345kV

Type ACFHV is designed for corona-free service at 345kV. The catalog numbers below are without pad hardware shields. When shields are required, add suffix -HS to catalog number. EXAMPLE: ACFHV-50-4B-HS
Shipped with inhibitor-coated contact surfaces.
NOTE: See hardware shields AA-1094.

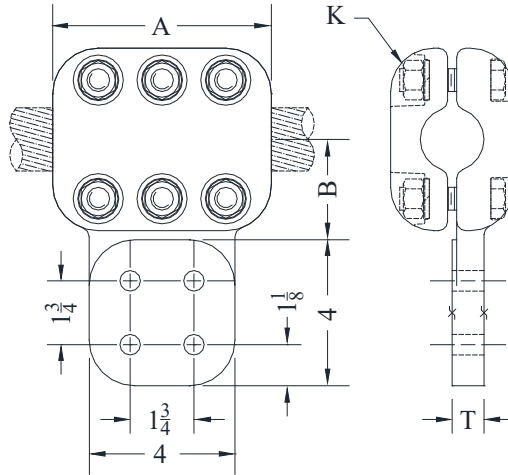

CATALOG NUMBER	CONDUCTOR SIZE (MCM)		DIMENSIONS - INCHES			
	AAC	ACSR	A	B	K	T
ACFHV-35-4B	900-1033	795	5	3	1/2	3/4
ACFHV-36-4B	1033.5-1113	954-1033.5	4-1/8	2-1/2	1/2	3/4
ACFHV-39-4B	1100-1272	1033-1113	4-1/8	2-1/2	1/2	3/4
ACFHV-41-4B	1351-1431	1192-1272	4-1/8	2-1/2	1/2	3/4
ACFHV-43-4B	1590	1351-1431	4-1/4	2-1/2	1/2	3/4
ACFHV-46-4B	1590-1750	1590	4-1/4	2-3/4	5/8	3/4
ACFHV-50-4B	2000-2303.5	2034-2167	6	2-3/4	5/8	7/8
ACFHV-52-4B	2500	2156	6	2-3/4	5/8	1
ACFHV-54-4B	3000	----	6	2-3/4	5/8	1
ACFHV-56-4B	3500	----	6-1/4	3-1/8	5/8	3/4

TYPE ACF2-HV

Bolted Straight
Two Cable Main to Flat Pad Tap

Casting Alloy: 356-T6 Aluminum
Clamping Hardware: Aluminum Alloy

ALUMINUM • 345kV - 500kV

NOTE: See hardware shields AA-1094

Type ACF2-HV is designed for corona-free full current service at 345kV and 500kV, as listed below. Cable spacing other than shown in the table may be specified by changing the catalog number suffix. If pad hardware shields are required, add suffix -HS to catalog number. Example: ACF2-HV-39-4B-HS.

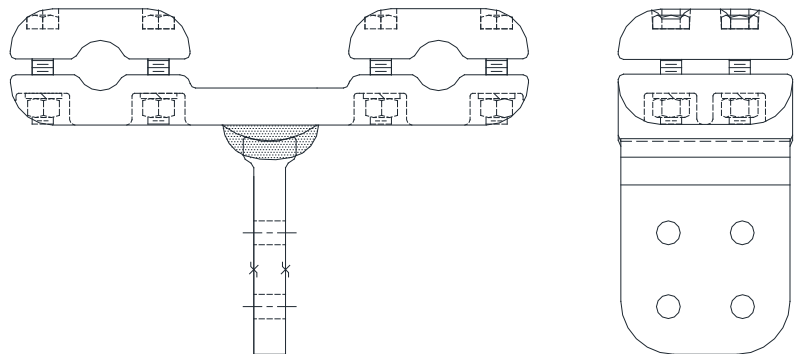

EHV TEE CONNECTORS

TYPE ACFHV2

Bolted Straight
Two Cable Main to Flat Pad Tap

Casting Alloy: 356-T6 Aluminum
Clamping Hardware: Aluminum Alloy
Spacer Pipe: 6061-T6 Aluminum

Type ACFHV2 is designed for corona-free service at 345kV and 500kV, as listed below. Cable spacing other than shown in the table may be specified by changing the catalog number suffix. If pad hardware shields are required, add suffix -HS to catalog number. Example: ACFHV-38-12-HS.

NOTE: See hardware shields AA-1094.

ALUMINUM • 345 - 500kV

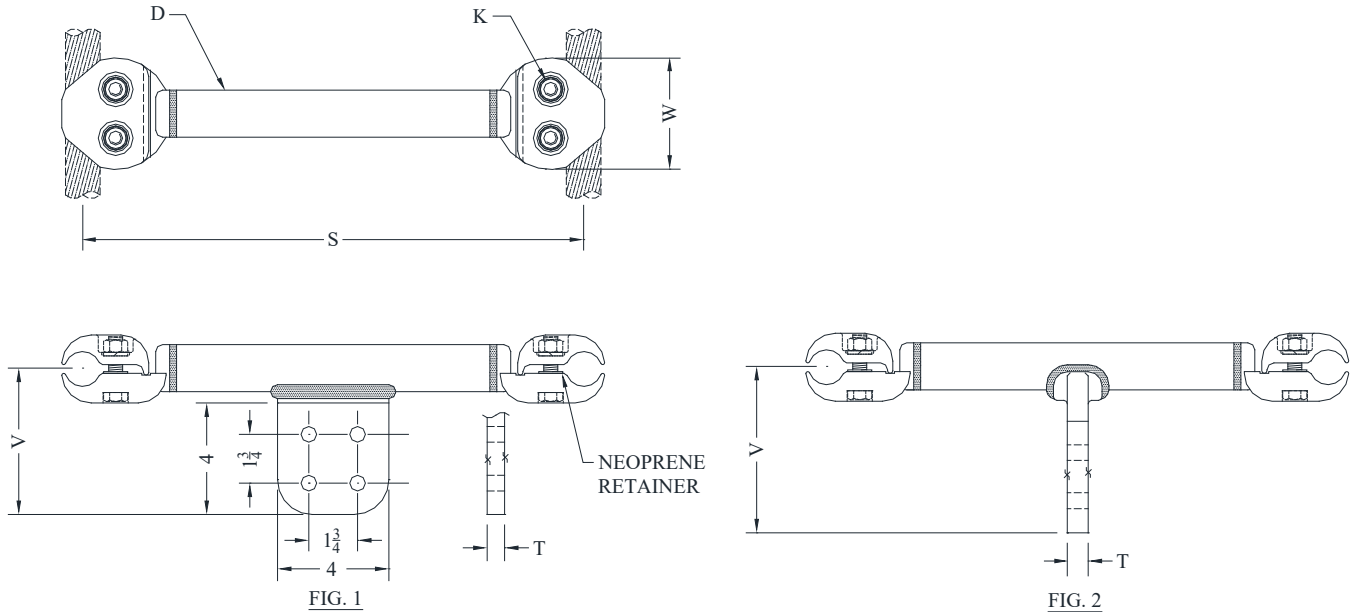

CATALOG NUMBER		CONDUCTOR RANGE		DIMENSIONS - INCHES					
FIG. 1	FIG. 2	AAC	ACSR	D	K	S	T	V	W
FOR 345kV SERVICE									
ACFHV2-32-12	ACFHV2-32-12R	795 - 900	715 - 795	1.32	1/2	12	5/8	5-1/4	4
ACFHV2-35-12	ACFHV2-35-12R	954 - 1033	795 - 954	1.32	1/2	12	5/8	5-1/4	4
ACFHV2-38-12	ACFHV2-38-12R	1113 - 1192	1033 - 1113	1.66	1/2	12	3/4	5-15/16	4
ACFHV2-41-12	ACFHV2-41-12R	1272 - 1431	1192 - 1272	1.66	1/2	12	3/4	5-15/16	4
ACFHV2-43-12	ACFHV2-43-12R	1510 - 1600	1351 - 1451	1.66	1/2	12	3/4	5-15/16	4
ACFHV2-46-12	ACFHV2-46-12R	1750	1510 - 1590	1.66	1/2	12	3/4	5-7/8	4
FOR 500kV SERVICE									
ACFHV2-46-18	ACFHV2-46-18R	1750	1510 - 1590	1.66	1/2	18	3/4	5-15/16	4
ACFHV2-48-18	ACFHV2-48-18R	1933 - 2031	---	1.66	1/2	18	3/4	6-3/32	4
ACFHV2-51-18	ACFHV2-51-18R	2250 - 2500	2034 - 2167	1.66	5/8	18	3/4	6	4-3/8
ACFHV2-54-18	ACFHV2-54-18R	2750 - 3000	2515	1.66	5/8	18	3/4	6	4-3/4
ACFHV2-56-18	ACFHV2-56-18R	3500	---	4.00	5/8	18	3/4	6-1/16	6-1/4

EHV TEE CONNECTORS

TYPE ACRCT-HV

Bolted Straight
Cable Main to Cable Tap

Type ACRCT-HV is designed for corona-free service at a voltage level equal to or higher than the conductor rating.

Used for single or bundled-conductor taps.

Finished contact surfaces are factory-coated with an oxidation inhibitor.

Casting Alloy: 356-T6 Aluminum
Clamping Hardware: Aluminum Alloy

ALUMINUM • 345 - 500kV

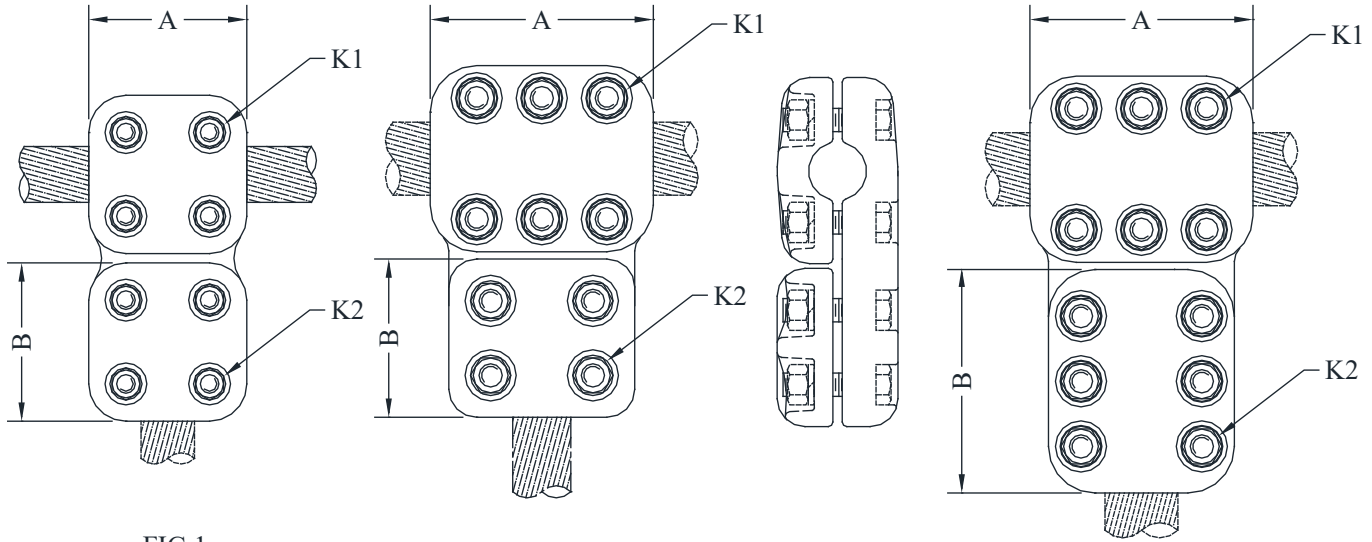

FIG 1.

FIG 2.

FIG 3.

CATALOG NUMBER	FIG. NO.	CABLE RUN (MCM)		CABLE TAP (MCM)		DIMENSIONS - INCHES			
		AAC	ACSR	AAC	ACSR	A	B	K1	K2
ACRCT-HV-3434	1	954 - 1000	795	954 - 1000	795	3-3/4	3-3/4	1/2	1/2
ACRCT-HV-3535	1	1033	874	1033	874	3-3/4	3-3/4	1/2	1/2
ACRCT-HV-3636	1	1113	954	1113	954	4-1/8	4-1/8	1/2	1/2
ACRCT-HV-3939	1	1192 - 1272	1033 - 1113	1192 - 1272	1033 - 1113	4-1/8	4-1/8	1/2	1/2
ACRCT-HV-4141	1	1351 - 1431	1272	1351 - 1431	1272	4-1/4	4-1/4	1/2	1/2
ACRCT-HV-4334	1	1590	1431	954	795	4-1/4	3-3/4	5/8	1/2
ACRCT-HV-4343	1	1510 - 1590	1351 - 1431	1510 - 1590	1351 - 1431	4-1/4	4-1/4	5/8	5/8
ACRCT-HV-4646	1	1800	1590	1800	1590	4-1/4	4-1/4	5/8	5/8
ACRCT-HV-4949	3	2000 - 2250	1780 - 2167	2000 - 2250	1780 - 2167	6	6	5/8	5/8
ACRCT-HV-5243	2	2500	2156	1590	1351 - 1431	6	4-1/4	5/8	5/8
ACRCT-HV-5246	3	2500	2156	1800	1590	6	6	5/8	5/8
ACRCT-HV-5252	3	2500	2515	2500	2515	6	6	5/8	5/8
ACRCT-HV-5652	3	3500	----	2500	2156	6-1/4	6	5/8	5/8
ACRCT-HV-5656	3	3500	----	3500	----	6-1/4	6-1/4	5/8	5/8

EHV BUS SUPPORTS

TYPE ATFHV/ATFRHV

Bolted Straight
Pipe Main to Flat Pad Tap

Types ATFHV and ATFRHV are designed for corona-free service at the voltage levels shown. The catalog numbers below are without pad hardware shields. If shields are required, add suffix -HS. Example: ATFHV-67-4B-HS. Shipped with inhibitor-coated contact surfaces.
NOTE: See hardware shields AA-1094.

Casting Alloy: 356-T6 Aluminum
Clamping Hardware: Aluminum Alloy

ALUMINUM • 345 - 500kV

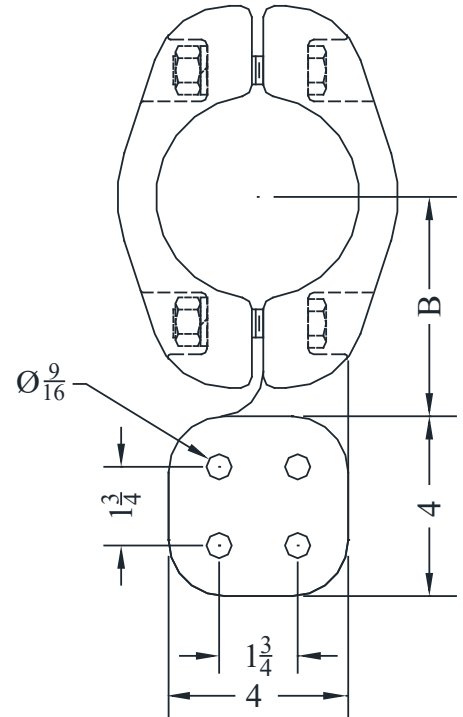
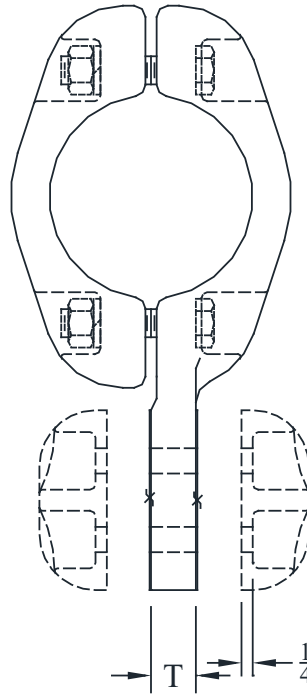
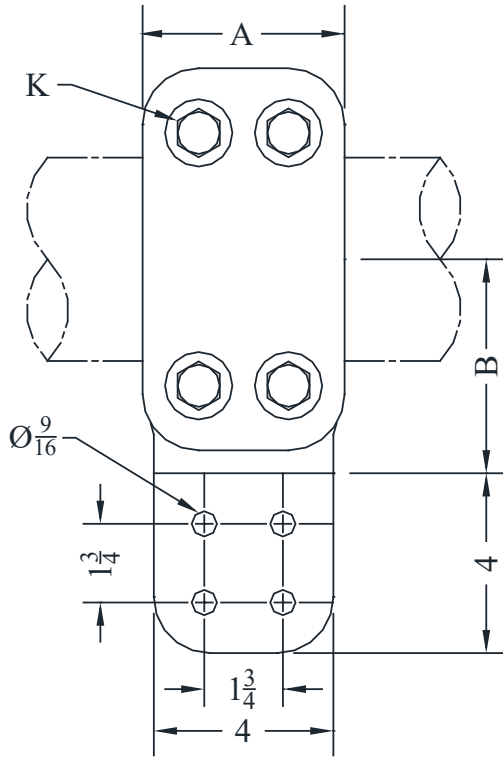

TYPE ATFHV

TYPE ATFRHV

CATALOG NUMBER		PIPE SIZE (NPS)	MAX KV	DIMENSIONS - INCHES			
TYPE ATFHV	TYPE ATFRHV			A	B	K	T
ATFHV-58-4B	ATFRHV-58-4B	2	345	4	2-1/2	1/2	1/2
ATFHV-60-4B	ATFRHV-60-4B	2-1/2	345	4	2-9/16	5/8	3/4
ATFHV-62-4B	ATFRHV-62-4B	3	500	4-1/2	4	5/8	1
ATFHV-63-4B	ATFRHV-63-4B	3-1/2	500	5	4-1/4	5/8	1
ATFHV-64-4B	ATFRHV-64-4B	4	500	4-1/2	4-3/4	5/8	1
*ATFHV-67-4B	ATFRHV-67-4B	5	500	8-1/4	5-1/8	5/8	1
*ATFHV-69-4B	ATFRHV-69-4B	6	500	7	5-1/2	5/8	1

*Six clamping bolts on pipe

EHV TEE CONNECTORS

TYPE ATTHV

Bolted Tee

Pipe Main to Pipe Tap

Type ATTHV is designed for corona-free service at the voltage levels shown below. The finished contact surfaces are protected by factory-applied oxidation inhibitor.

Casting Alloy: 356-T6 Aluminum
Clamping Hardware: Aluminum Alloy

ALUMINUM • 345 - 500kV

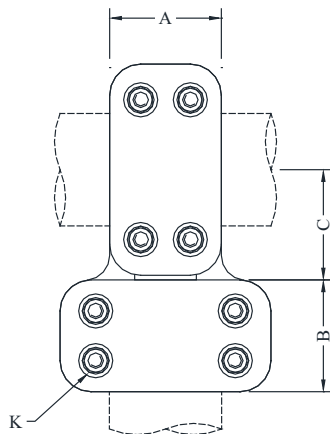

FIG. 1

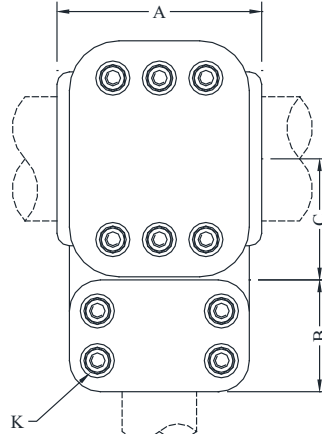

FIG. 2

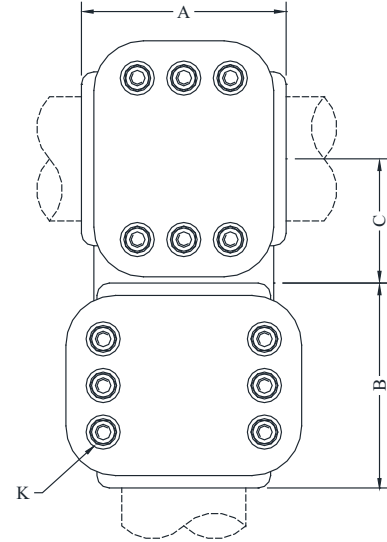

FIG. 3

CATALOG NUMBER	FIG. NO.	PIPE SIZE (NPS)		MAX KV	DIMENSIONS - INCHES			
		MAIN	TAP		A	B	C	K
ATTHV-5858	1	2	2	345	6-1/4	6-1/4	3-1/8	5/8
ATTHV-6058	1	2-1/2	2	345	4	4	3-3/4	5/8
ATTHV-6060	1		2-1/2	345	4	4	3-3/4	5/8
ATTHV-6260	1	3	2-1/2	345	5	4	3-5/8	5/8
ATTHV-6262	1		3	500	5	5	3-5/8	5/8
ATTHV-6360	1	3-1/2	2-1/2	345	5	4	3-7/8	5/8
ATTHV-6362	1		3	500	5	5	3-7/8	5/8
ATTHV-6363	1		3-1/2	500	5	5	3-3/4	5/8
ATTHV-6460	1	4	2	345	4-1/2	4	4-3/8	5/8
ATTHV-6462	1		3	500	4-1/2	4-1/2	4-7/16	5/8
ATTHV-6464	1		4	500	4-1/2	4-1/2	4-7/16	5/8
ATTHV-6760	2	5	2-1/2	500	8-1/4	4	5-1/8	5/8
ATTHV-6762	2		3	500	8-1/4	4-1/2	4-7/8	5/8
ATTHV-6763	2		3-1/2	500	8-1/4	4-1/2	4-7/8	5/8
ATTHV-6767	3		5	500	8-1/4	8-1/4	5	5/8
ATTHV-6962	2	6	3	500	7	4-1/2	5-1/8	5/8
ATTHV-6963	2		3-1/2	500	7	4-1/2	5-1/8	5/8
ATTHV-6964	2		4	500	7	4-1/2	5-1/2	5/8
ATTHV-6969	3		6	500	7	7	6	5/8

EHV BUS SUPPORTS

TYPE AVTHV-15

TYPE ATTHV-15

Bolted "A" Frame Connectors

Types AVTHV & ATTHV are designed for corona-free service through 500kV. They are commonly used for removable A-frame assemblies. Shipped with inhibitor - coated contact surfaces.

Casting Alloy: 356-T6 Aluminum
Clamping Hardware: Aluminum Alloy

ALUMINUM • 345 - 500kV

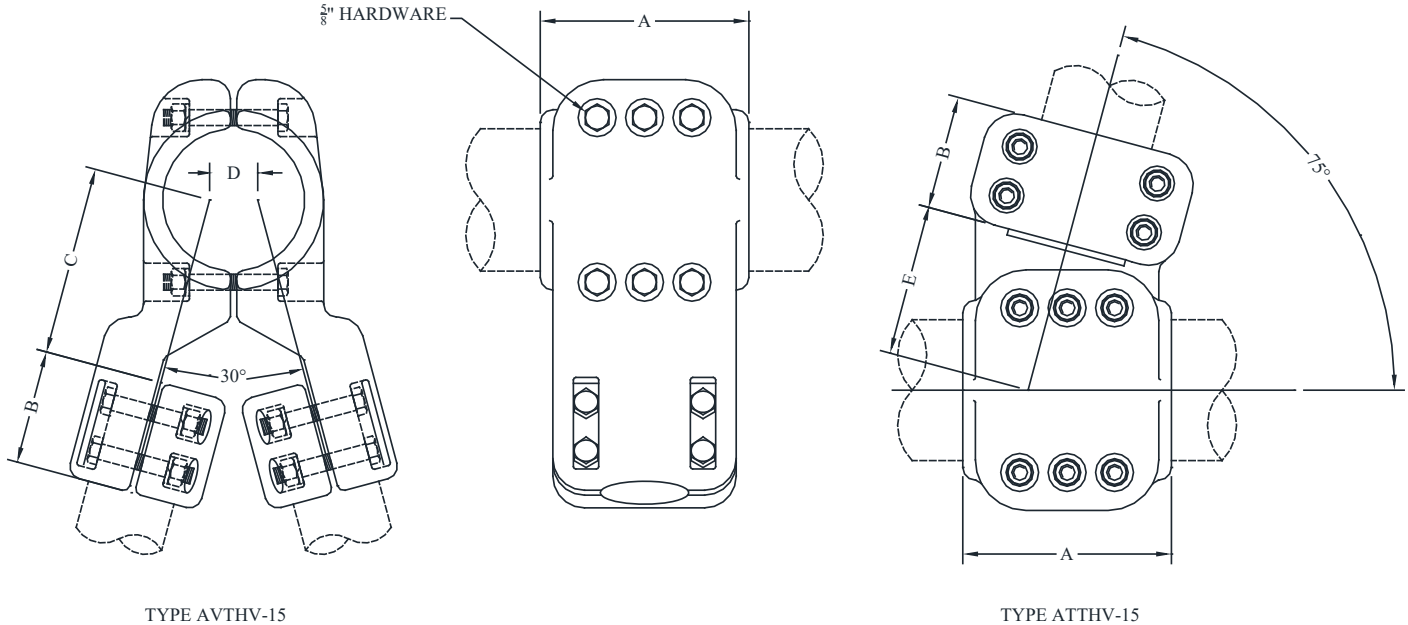

TYPE AVTHV-15

TYPE ATTHV-15

CATALOG NUMBER		PIPE SIZE (NPS)		DIMENSIONS - INCHES				
TYPE AVTHV-15	TYPE ATTHV-15	MAIN	TAP(S)	A	B	C	D	E
-----	ATTHV-15-6060	2-1/2	2-1/2	4	4	---	---	4-1/8
-----	ATTHV-15-6262	3	3	4-1/2	4-1/2	---	---	4-7/16
-----	ATTHV-15-6363	3-1/2	3-1/2	4-1/2	4-1/2	---	---	5-3/16
AVTHV-15-6462	ATTHV-15-6462	4	3	4-1/2	4-1/2	6-1/2	3	5-1/4
AVTHV-15-6762	ATTHV-15-6762	5	3	8-1/4	4-1/2	7	2	5-3/4
AVTHV-15-6763	ATTHV-15-6763		3-1/2	8-1/4	4-1/2	7	3	5-7/8
AVTHV-15-6764	ATTHV-15-6764		4	8-1/4	4-1/2	7	3	6
AVTHV-15-6962	ATTHV-15-6962	6	3	7	4-1/2	7-1/2	2	6-1/4
AVTHV-15-6963	ATTHV-15-6963		3-1/2	7	4-1/2	7-1/2	2	6-1/4
AVTHV-15-6964	ATTHV-15-6964		4	7	4-1/2	7-1/2	3	6-1/2

EHV TEE CONNECTORS

TYPE WFVT15-HV

TYPE WFTT15-HV

Welded "A"-Frame Connectors

Type WFVT-HV and WFTT-HV are designed for corona-free service within the voltage limitations of the A-frame pipe members. Fittings are sanded and wire-brushed to meet EHV requirements in finish and appearance.

Casting Alloy: 356-T6 Aluminum

ALUMINUM • 345 - 500kV

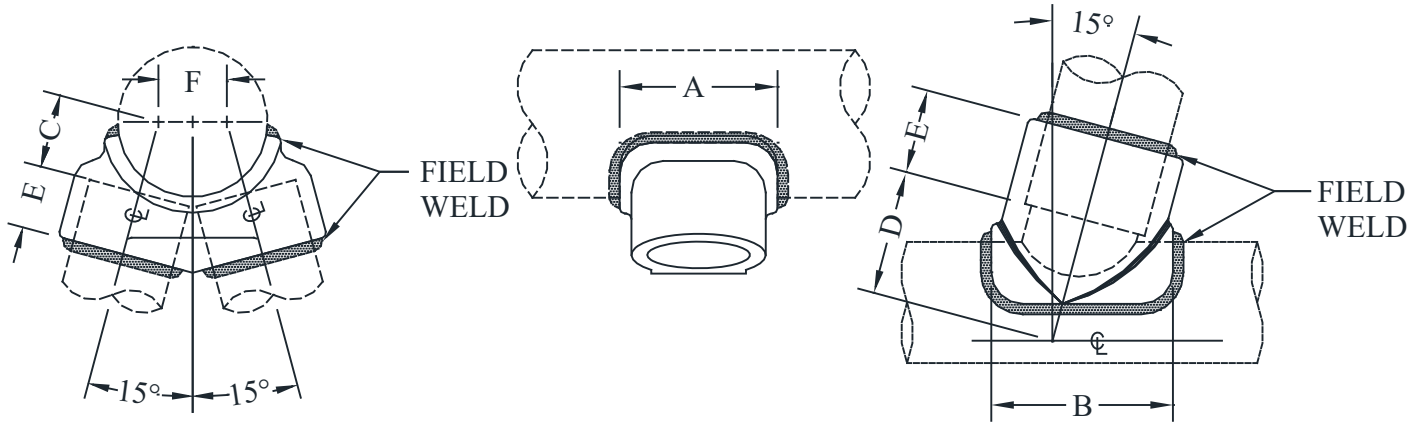

CATALOG NUMBER		PIPE SIZE (NPS)		DIMENSIONS - INCHES					
TYPE WFVT-HV	TYPE WFTT-HV	MAIN	TAP(S)	A	B	C	D	E	F
WFVT15-6060-HV	WFTT15-6060-HV	2-1/2	2-1/2	4-1/4	4-3/8	1-3/8	2-1/8	2	2-1/4
WFVT15-6260-HV	WFTT15-6260-HV	3	2-1/2	4-1/4	4-1/2	1-5/8	2-3/8	2	2-1/4
WFVT15-6262-HV	WFTT15-6262-HV		3	5-1/4	5-3/8	1-5/8	2-1/2	2-1/2	2-7/8
WFVT15-6360-HV	WFTT15-6360-HV	3-1/2	2-1/2	4-1/4	4-3/8	2-3/8	2-1/2	2	1-3/4
WFVT15-6363-HV	WFTT15-6363-HV		3-1/2	5-3/4	6-1/8	2-1/4	2-7/8	2-1/2	3-1/4
WFVT15-6460-HV	WFTT15-6460-HV	4	2-1/2	4-1/4	4-5/8	2-3/8	3	2	1-3/4
WFVT15-6462-HV	WFTT15-6462-HV		3	4-3/4	5-3/4	2-1/4	3	2-1/2	2-1/2
WFVT15-6464-HV	WFTT15-6464-HV		4	6-1/4	6-5/8	2-3/4	3-3/4	3	3-1/2
WFVT15-6760-HV	WFTT15-6760-HV	5	2-1/2	4-1/2	4-7/8	2-7/8	3-1/2	2	1-5/8
WFVT15-6762-HV	WFTT15-6762-HV		3	4-3/4	5-1/2	2-3/4	3-3/4	2-1/2	2-1/4
WFVT15-6763-HV	WFTT15-6763-HV		3-1/2	5-3/4	5-7/8	2-7/8	3-5/8	2-1/2	2-3/4
WFVT15-6767-HV	WFTT15-6767-HV		5	8	7-3/4	3	4	3	4
WFVT15-6962-HV	WFTT15-6962-HV	6	3	5-3/8	5-3/8	3-1/2	4-1/8	2-1/2	2
WFVT15-6963-HV	WFTT15-6963-HV		3-1/2	5-3/4	5-7/8	3-1/4	4-1/8	2-1/2	2-1/2
WFVT15-6964-HV	WFTT15-6964-HV		4	6-3/4	6-5/8	3-1/4	4-1/4	3	2-3/4
WFVT15-6967-HV	WFTT15-6967-HV		5	8	7-3/4	3-1/8	4-1/2	3	4

EHV TEE CONNECTORS

TYPE WFTT-HV

Welded Tee
Pipe Main to Pipe Tap

Type WFTT-HV is designed for corona-free service within the voltage limitations of the pipe size on which it is used.

Fittings are sanded and wire-brushed to meet the EHV requirements in finish and appearance.

Casting Alloy: 356-T6 Aluminum

ALUMINUM • 345 - 500kV

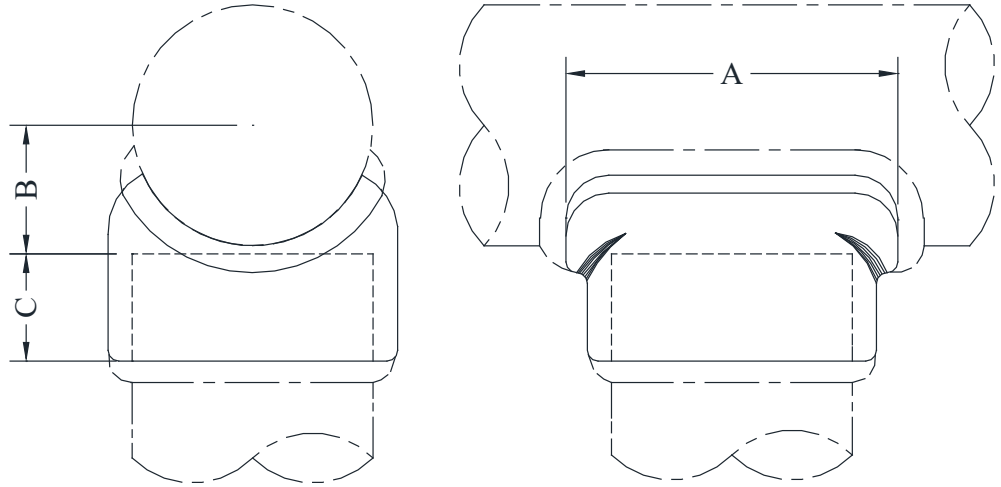

CATALOG NUMBER	PIPE SIZE (NPS)		DIMENSIONS - INCHES		
	MAIN	TAP	A	B	C
WFTT-6058-HV	2-1/2	2	3-1/2	1-9/16	1-5/16
WFTT-6060-HV		2-1/2	4-1/4	1-9/16	2
WFTT-6260-HV	3	2-1/2	4-1/2	2	1-3/4
WFTT-6262-HV		3	5	2	1-3/4
WFTT-6360-HV	3-1/2	2-1/2	4-1/8	2-1/8	2
WFTT-6362-HV		3	5-1/2	2-1/8	2-3/8
WFTT-6363-HV		3-1/2	5-1/2	2-1/8	2-3/8
WFTT-6460-HV	4	2-1/2	4-1/4	2-1/2	2
WFTT-6462-HV		3	5-1/4	2-3/8	2-1/2
WFTT-6463-HV		3-1/2	6	2-1/2	2-3/4
WFTT-6464-HV		4	6-1/4	2-3/8	2-3/8
WFTT-6760-HV	5	2-1/2	4-1/4	3	2
WFTT-6762-HV		3	5-1/8	3	2-1/2
WFTT-6763-HV		3-1/2	5-1/2	3	2-3/8
WFTT-6764-HV		4	6	3	2-1/2
WFTT-6767-HV		5	7-3/4	3	2-1/2
WFTT-6960-HV	6	2-1/2	4-1/2	3-1/2	2
WFTT-6962-HV		3	4-7/8	3-1/2	2-1/2
WFTT-6963-HV		3-1/2	5-1/4	3-1/2	2-3/8
WFTT-6964-HV		4	6	3-9/16	2-1/2
WFTT-6967-HV		5	7-1/2	3-5/8	2-1/2
WFTT-6969-HV		6	8-1/4	3-5/8	3

EHV TEE CONNECTORS

TYPE WTC

Welded Tee

Pipe Main to Cable Tee

Type WTC is designed for corona-free service at 345kV, or for 500kV when paired for bundled conductors.

Casting Alloy: 356-T6 Aluminum

ALUMINUM • 345 - 500kV

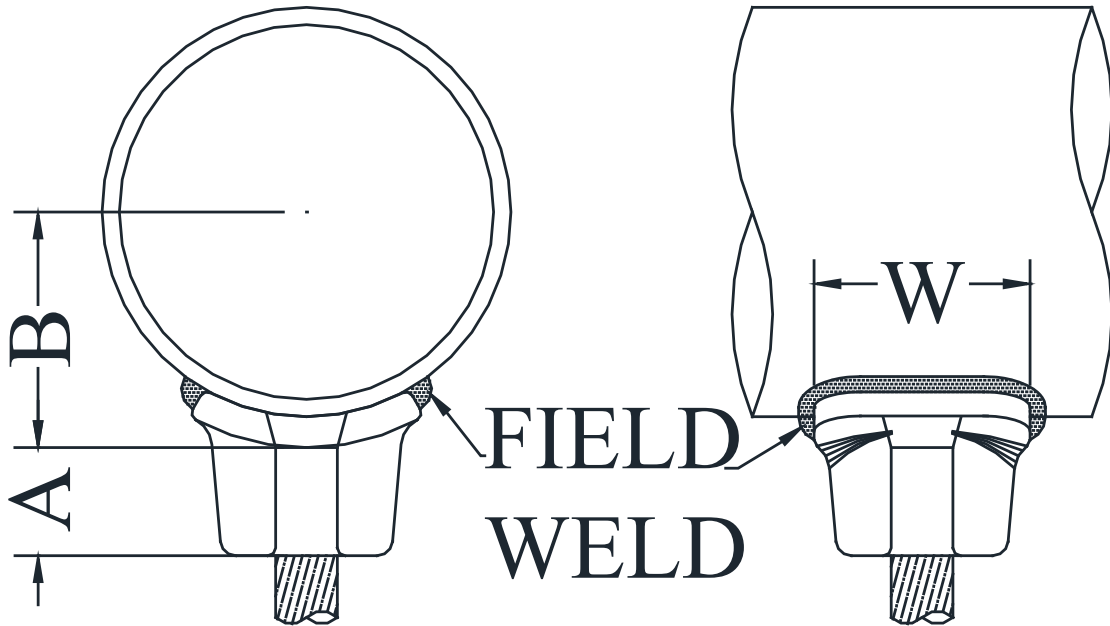

CATALOG NUMBER	PIPE SIZE (NPS)	CABLE SIZE	DIMENSIONS - INCHES		
		AAC	A	B	W
WTC-6035	2-1/2	1000 - 1033 MCM	2-7/8	1-3/4	1-1/2
WTC-6039		1250 - 1272 MCM	3	1-3/4	1-5/8
WTC-6235	3	1000 - 1033 MCM	2-7/8	2-1/8	1-1/2
WTC-6239		1250 - 1300 MCM	1-1/8	2-1/16	2-1/2
WTC-6241		1250 - 1510 MCM	1-1/2	2-1/8	2-3/4
WTC-6335	3-1/2	1000 - 1033 MCM	2-7/8	2-3/8	1-1/2
WTC-6339		1250 - 1300MCM	3	2-3/8	1-5/8
WTC-6341		1351 - 1431 MCM	1-1/2	2-3/8	2-3/4
WTC-6435	4	1000 - 1033 MCM	2-7/8	2-5/8	1-1/2
WTC-6439		1250 - 1300 MCM	1-5/8	2-3/4	3
WTC-6441		1351 - 1431 MCM	1-5/8	2-3/4	3
WTC-6443		1500 - 1600 MCM	1-5/8	2-3/4	3
WTC-6739	5	1250 - 1300 MCM	1-5/8	2-7/8	3-1/4
WTC-6741		1351 - 1431 MCM	1-5/8	3-1/4	3-1/4
WTC-6743		1500 - 1600 MCM	1-5/8	2-7/8	3-1/4
WTC-6746		1750 - 1800 MCM	1-5/8	2-7/8	3-1/4

EHV TEE CONNECTORS

TYPE WTF-HV/WTFR-HV

Welded Tee

Cable Main to Flat Pad Tap

Type WTF-HV and WTFR-HV are designed for corona-free service at 345kV or 500kV when used with EHV tap connectors and hardware shields. Hardware shield No. AA-1094 must be ordered separately as required. NOTE: See hardware shields AA-1094.

Casting Alloy: 356-T6 Aluminum

ALUMINUM • 345 - 500kV

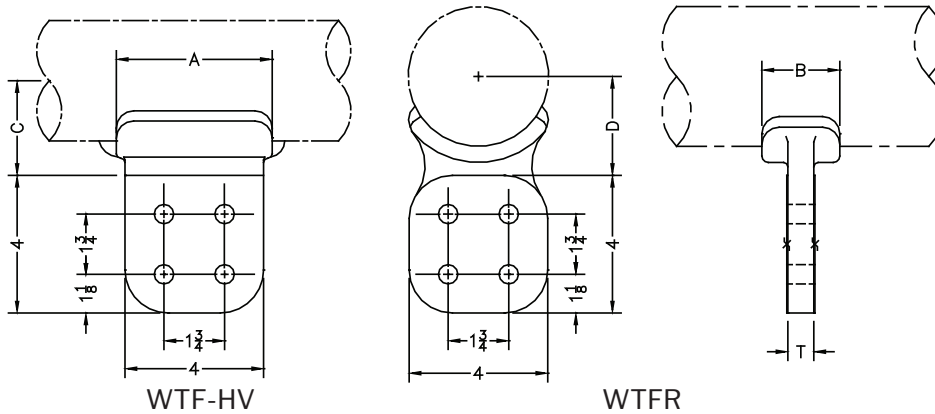

CATALOG NUMBER		PIPE SIZE (NPS)	DIMENSIONS - INCHES				
TYPE WTF	TYPE WTFR		A	B	C	D	T
WTF-60-4B-HV	WTFR-60-4B-HV	2-1/2	4-1/2	1-1/4	2-3/8	2-1/4	3/4
WTF-62-4B-HV	WTFR-62-4B-HV	3	4-1/2	2-1/4	2-3/4	2-5/8	3/4
WTF-63-4B-HV	WTFR-63-4B-HV	3-1/2	4-1/2	2-1/4	2-7/8	2-7/8	3/4
WTF-64-4B-HV	WTFR-64-4B-HV	4	4-1/2	2-1/4	3-1/4	3-1/8	3/4
WTF-67-4B-HV	WTFR-67-4B-HV	5	4-1/2	3	3-3/4	3-3/4	1
WTF-69-4B-HV	WTFR-69-4B-HV	6	4-1/2	4	4-5/16	4-5/8	1

TYPE

WTF-6269-4B-HV

Welded Tee

Pipe Main to Flat Pad Tap

Accommodates 3" NPS through 6" NPS pipe. Pad has NEMA drilling as shown above. Pad thickness is 3/4 inch. Note: Not intended for full current application.

Castings: 356-T6 Aluminum

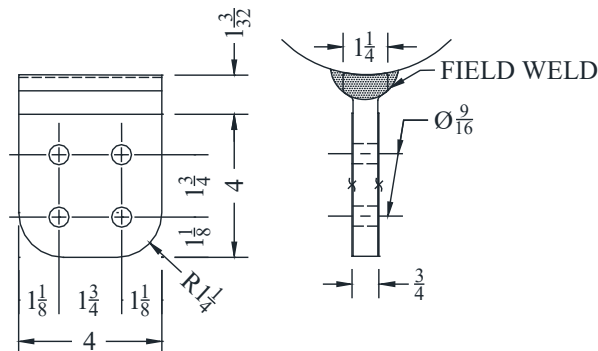

EHV TEE CONNECTORS

TYPE WTTCC

Welded Expansion
Pipe Main to Pipe Tap

Type WTTCC is rated for corona-free service through 345kV Due to the orientation of the flexible elements, a total movement of $\pm 1\text{-}1/2''$ is accommodated.
Specify NPS SCH 40 or SCH 80.

Casting Alloy: 356-T6 Aluminum
Flexible Elements: Class A Stranded Cable

ALUMINUM • 345 - 500kV

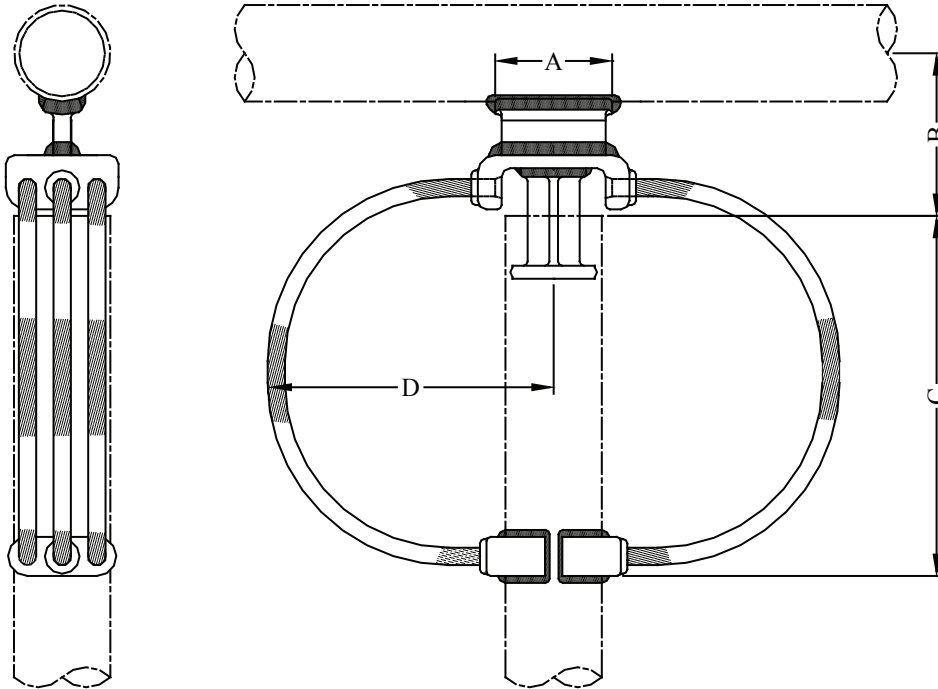

CATALOG NUMBER	PIPE SIZE (NPS)		DIMENSIONS - INCHES			
	MAIN	TAP	A	B	C	D
WTTCC-6262	3	3	5	5-1/2	15	12
WTTCC-6362	3-1/2	3	5	5-3/4	15	12
WTTCC-6363		3-1/2	5-1/2	5-3/4	15	12
WTTCC-6462	4	3	5	6	15	12
WTTCC-6464		4	6-1/4	6-1/2	15-1/2	12
WTTCC-6762	5	3	5	6-5/8	15	12
WTTCC-6763		3-1/2	5-1/2	6-5/8	15	12
WTTCC-6764		4	6-1/4	6-5/8	15-1/2	12
WTTCC-6767		5	7-3/4	9-3/8	18-1/2	15
WTTCC-6962	6	3	5	7-1/8	15	12
WTTCC-6963		3-1/2	5-1/2	7-1/8	15	12
WTTCC-6964		4	6-1/4	7-1/8	15-1/2	12
WTTCC-6967		5	7-3/4	7-1/8	21	15
WTTCC-6969		6	8-1/4	7-1/8	24	18

EHV TEE CONNECTORS

TYPE WTTC3

Welded Tee

Pipe Main to Three Flat Pad Taps

Casting Alloy: 356-T6 Aluminum

ALUMINUM • 345 - 500kV

Type WTTC3 is designed for corona-free service at 500kV, when used with three (3) compression terminals to form a trifurcating pipe-cable connection. Hardware shields are not required when terminal mounting hardware is arranged so that nuts are inside the bell.

Mounting hardware must be ordered separately.

Note: This fitting is designed for welding at the center line of the bus as shown. Welding around the saddle is not necessary and is not recommended for mid-span taps.

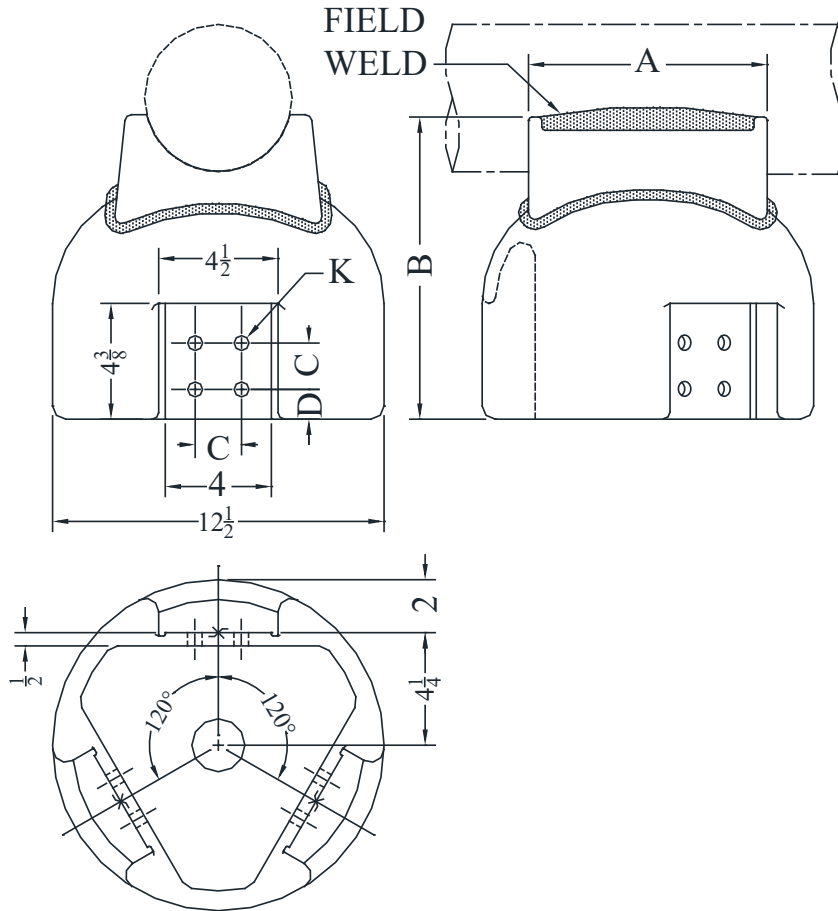

CATALOG NUMBER	PIPE SIZE (NPS)	DIMENSIONS - INCHES				
		A	B	C	D	K
WTTC3-62	3	6	13-3/4	1-3/4	1-1/8	9/16
WTTC3-63	3-1/2	7	11-1/4	1-3/4	1-1/8	9/16
WTTC3-64	4	8	11-1/2	1-3/4	1-1/8	9/16
WTTC3-67	5	9	12-1/8	1-3/4	1-1/8	9/16
WTTC3-69	6	9	12-1/2	1-3/4	1-1/8	9/16

ALUMINUM TERMINALS



AFNC



AFNC90



AFNC2



AFNC3



WFC



WFC2



AFNT



AFNT90



AFNTC



WFT



WFTC



WFTI



WFTIC



WFTO



WFTOC



WFTIR



WFTIW



WFXIW

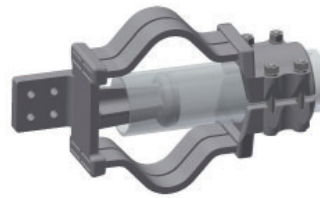

AFXTO

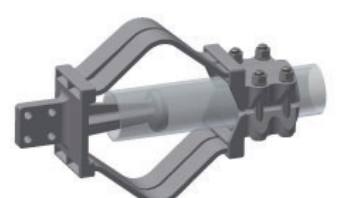

AFXTO

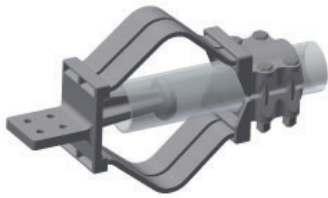

AFXTO-V



ASFFT



ASFFT90



WFXTO



WFXTC



WFXTC-V



WSFFT



WSFFT90

ALUMINUM TERMINALS

SEFCOR aluminum terminals are cast from certified aluminum alloy 356 ingot. The castings are heat treated to T6 temper. Only high quality electrical aluminum per ASTM-26B is utilized to insure the current-carrying capability as well as mechanical strength. Alloy 356 is not susceptible to stress corrosion.

This section is arranged in the following sequence for the convenience of the user:

Cable to Flat Pad Pipe to Flat Pad Expansion

OPTIONS

A suffix added to a catalog number denotes a variation or option made to the standard cataloged item. The suffixes listed below display the various options available with **SEFCOR** aluminum terminals. Consult manufacturer for further details, unlisted and/or special applications.

B	—	Flexible braid elements in lieu of laminations
BP	—	Blank contact pad
CF	—	Copper-face plate on contact pad
CNS	—	Supplied with cap nuts
E	—	Extension pad
FF	—	Finish both sides of contact pad when not customary to do so
GR5	—	Grade 5 Stainless steel bolt with stainless steel washer and nut
GS	—	Galvanized steel hardware in lieu of standard hardware
H	—	For internal fit terminals when SCH 80 pipe is required
MB	—	With tongue mounting hardware
M72	—	Stainless steel bolt and washer with Silicon Bronze nut.
SP	—	Special requirement, refer to factory
SS	—	Stainless steel hardware in lieu of standard hardware
TTP	—	Terminal supplied with Bimetallic transition plate

NOTE:

1. Actual dimensions (other than those established by NEMA) of connectors shown may vary slightly. If exact dimensions are required, refer to factory or see assembly drawings.
2. Consult manufacturer for further details or unlisted applications.

ALUMINUM TERMINALS

TYPE AFNC

Straight Bolted
Cable to Flat Pad

Aluminum alloy terminal with hex head clamping bolts for connecting aluminum cable to flat pad. Clamping bolts have hex-stops for one-wrench installation. Side form tongues. Flat pads have NEMA drilling. Contact sealant is recommended. Wide cable ranges using reversible caps are available and are listed at the end of the table.

Casting Alloy: 356-T6 Aluminum
Clamping Hardware: Aluminum Alloy
Options: See Page 89

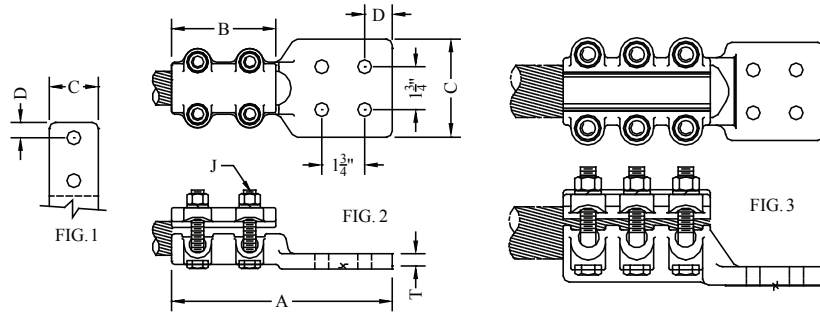

CATALOG NUMBER	FIG. NO.	CONDUCTOR RANGE		DIMENSIONS - INCHES						WEIGHT (POUNDS)
		AAC	ACSR	A	B	C	D	J	T	
AFNC-13-2B	1	#4 - 266 MCM	#4 - 4/0 STR	6-1/4	3	2	5/8	1/2	5/16	1.00
AFNC-13-4A	2			6-1/4	3	3	5/8	1/2	5/16	1.20
AFNC-13-4B	2			7-1/4	3	4	1-1/8	1/2	5/16	1.40
AFNC-20-2B	1	4/0 - 500 MCM	4/0 - 397 MCM	7	3-1/2	2	5/8	1/2	3/8	1.30
AFNC-20-4A	2			7	3-1/2	3	5/8	1/2	3/8	1.45
AFNC-20-4B	2			7-7/8	3-1/2	4	1-1/8	1/2	3/8	1.50
AFNC-24-2B	1	350 - 650 MCM	336 - 556 MCM	7-3/8	4	2	5/8	1/2	3/8	1.50
AFNC-24-4A	2			7-1/2	4	3	5/8	1/2	3/8	1.60
AFNC-24-4B	2			8-1/2	4	4	1-1/8	1/2	3/8	1.70
AFNC-34-2B	1	550 - 1000 MCM	477 - 795 MCM	7-1/2	4	2	5/8	1/2	1/2	1.70
AFNC-34-4A	2			7-1/2	4	3	5/8	1/2	3/8	1.80
AFNC-34-4B	2			8-1/2	4	4	1-1/8	1/2	3/8	2.00
AFNC-39-2B	1	874 - 1300 MCM	715 - 1113 MCM	7-15/16	4-1/4	2	5/8	1/2	1/2	2.30
AFNC-39-4A	2			8-1/16	4-1/4	3	5/8	1/2	5/8	2.40
AFNC-39-4B	2			9	4-1/4	4	1-1/8	1/2	5/8	2.50
AFNC-43-2B	1	1250 - 1590 MCM	1113 - 1431 MCM	8-1/4	4-1/2	2	5/8	5/8	1/2	3.10
AFNC-43-4A	2			8-1/4	4-1/2	3	5/8	5/8	1/2	3.20
AFNC-43-4B	2			9-3/8	4-1/2	4	1-1/8	5/8	5/8	3.30
AFNC-46-2B	1	1250 - 1800 MCM	1113-1590 MCM	8-3/8	4-1/2	2	5/8	5/8	3/4	3.30
AFNC-46-4A	2			8-3/8	4-1/2	3	5/8	5/8	3/4	3.40
AFNC-46-4B	2			9-3/4	4-3/4	4	1-1/8	5/8	5/8	3.50
AFNC-49-2B	1	1500 - 2000 MCM	1272 - 1780 MCM	8-11/16	4-3/4	2	5/8	5/8	3/4	3.30
AFNC-49-4A	2			8-11/16	4-3/4	3	5/8	5/8	3/4	3.40
AFNC-49-4B	2			9-3/4	4-3/4	4	1-1/8	5/8	5/8	3.50
AFNC-56-4B	3	2000 - 3500 MCM	1780 - 3064 MCM	10-5/8	6	4	1-1/8	5/8	3/4	6.00
AFNC-1139-2B	1	4/0 - 1431 MCM	4/0 - 1272 MCM	7-15/16	4-1/4	2	5/8	1/2	1/2	2.30
AFNC-1139-4A	2			7-7/8	4-1/4	3	5/8	1/2	1/2	2.40
AFNC-1139-4B	2			9	4-1/4	4	1-1/8	1/2	5/8	2.50
AFNC-3653-4B	2	1100 - 2500 MCM	1113 - 2300 MCM	9-1/8	4	4	1-1/8	5/8	3/4	4.20

ALUMINUM TERMINALS

TYPE AFNC2

Straight Bolted

Two Cables to Flat Pad

Aluminum alloy terminal for connecting two aluminum cables to flat pad. Side formed tongues. Clamping bolts have hex-stops for one-wrench installation. Flat pads have NEMA drilling. Contact sealant is recommended. Angle connectors may be obtained by specifying desired angle. Example: AFNC290-34-4A

Wide cable ranges using reversible caps are available and are listed at the end of the table.

Casting Alloy: 356-T6 Aluminum
Clamping Hardware: Aluminum Alloy
Options: See Page 89

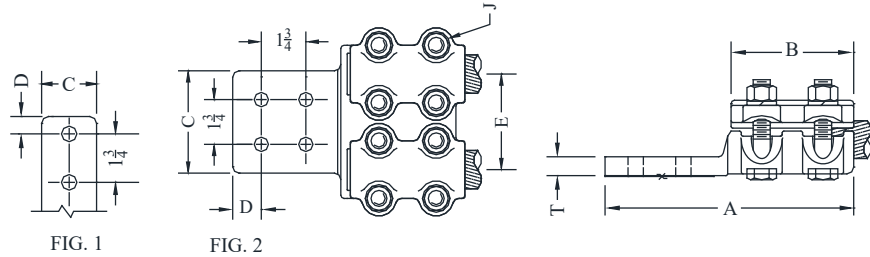

CATALOG NUMBER	FIG. NO.	CONDUCTOR RANGE		DIMENSIONS - INCHES							WEIGHT (POUNDS)
		AAC	ACSR	A	B	C	D	E	J	T	
AFNC2-13-2B	1	#4 - 266 MCM	#4 - 4/0 MCM	6-7/16	3	2	5/8	2-1/2	1/2	7/16	2.00
AFNC2-13-4A	2			6-7/16	3	3	5/8	2-1/2	1/2	7/16	2.00
AFNC2-13-4B	2			8-1/16	3	4	1-1/8	2-1/2	1/2	3/8	2.70
AFNC2-20-2B	1	4/0 - 500 MCM	4/0 - 397.5 MCM	7	3-1/2	2	5/8	2-3/4	1/2	1/2	2.50
AFNC2-20-4A	2			7	3-1/2	3	5/8	2-3/4	1/2	1/2	2.70
AFNC2-20-4B	2			8	3-1/2	4	1-1/8	2-3/4	1/2	1/2	3.00
AFNC2-24-2B	1	350 - 650 MCM	336 - 556 MCM	7-3/8	4	2	5/8	3	1/2	9/16	3.30
AFNC2-24-4A	2			7-3/8	4	3	5/8	3	1/2	9/16	3.30
AFNC2-24-4B	2			8-5/8	4	4	1-1/8	3-1/8	1/2	9/16	4.70
AFNC2-34-2B	1	550 - 1000 MCM	477 - 795 MCM	7-3/4	4	2	5/8	3-1/8	1/2	9/16	3.70
AFNC2-34-4A	2			7-3/4	4	3	5/8	3-1/8	1/2	9/16	3.70
AFNC2-34-4B	2			8-1/2	4	4	1-1/8	3-1/8	1/2	9/16	3.90
AFNC2-39-2B	1	874.5 - 1300 MCM	715.5 - 1113 MCM	8-1/4	4-1/4	2	5/8	3-1/4	1/2	3/4	4.70
AFNC2-39-4A	2			8-1/4	4-1/4	3	5/8	3-1/4	1/2	3/4	4.70
AFNC2-39-4B	2			9-1/4	4-1/4	4	1-1/8	3-1/4	1/2	3/4	5.20
AFNC2-43-2B	1	1250 - 1600 MCM	1113 - 1431 MCM	8-5/8	4-1/2	2	5/8	3-3/4	5/8	11/16	6.00
AFNC2-43-4A	2			8-3/8	4-1/2	3	5/8	3-3/4	5/8	1	6.10
AFNC2-43-4B	2			9-3/8	4-1/2	4	1-1/8	3-3/4	5/8	7/8	6.30
AFNC2-46-2B	1	1250 - 1800 MCM	1113 - 1590 MCM	8-11/16	4-3/4	2	5/8	3-7/8	5/8	3/4	6.50
AFNC2-46-4A	2			8-11/16	4-3/4	3	5/8	3-7/8	5/8	3/4	6.60
AFNC2-46-4B	2			9	4-3/4	4	1-1/8	3-7/8	5/8	3/4	6.80
AFNC2-49-2B	1	1500 - 2000 MCM	1272 - 1590 MCM	8-13/16	4-3/4	2	5/8	4-1/8	5/8	1	9.00
AFNC2-49-4A	2			8-13/16	4-3/4	3	5/8	4-1/8	5/8	1	9.20
AFNC2-49-4B	2			9-3/8	4-3/4	4	1-1/8	4-1/8	5/8	1	9.50
AFNC2-56-4B*	---	2000 - 3500 MCM	1780 - 3064 MCM	11-1/4	6	4	1-1/8	4-5/8	5/8	1	13.60
AFNC2-1139-2B	1	4/0 - 1300 MCM	4/0 - 1113 MCM	8-1/4	4-1/4	2	5/8	3-1/4	1/2	3/4	4.70
AFNC2-1139-4A	2			8-1/4	4-1/4	3	5/8	3-1/4	1/2	3/4	4.70
AFNC2-1139-4B	2			9-1/4	4-1/4	4	1-1/8	3-1/4	1/2	3/4	5.20
AFNC2-3653-4B	2	1100 - 2500 MCM	1113 - 2300 MCM	CONTACT FACTORY FOR DETAILS							

* Six clamping bolts per cap

SEFCOR

ALUMINUM TERMINALS

TYPE AFNC3

Straight Bolted

Three Cables to Flat Pad

Casting Alloy: 356-T6 Aluminum
Clamping Hardware: Aluminum Alloy
Options: See Page 89

Aluminum alloy terminal with hex head clamping bolts for connecting three aluminum cables to flat pad. Side formed tongues. Clamping bolts have hex stops for one-wrench installation. Flat pads have NEMA drilling. Contact sealant is recommended.

Angle connectors may be obtained by specifying desired angle.

Example: AFNC390-13-4A

Wide cable ranges using reversible caps are available and are listed at the end of the table.

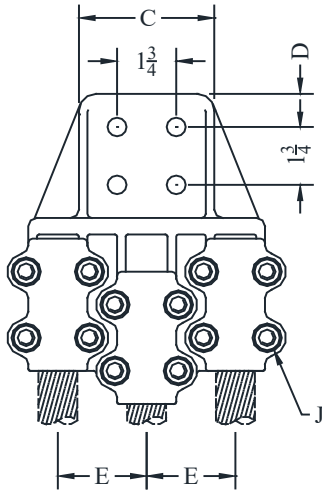

FIG. 1

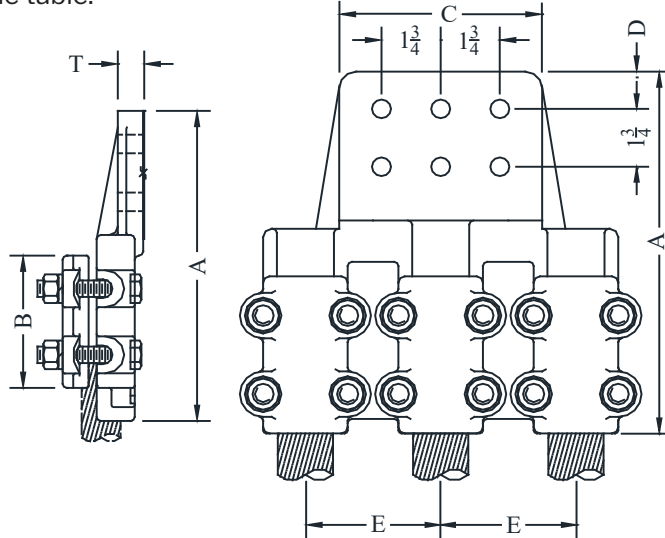

FIG. 2

CATALOG NUMBER	FIG. NO.	CONDUCTOR RANGE		DIMENSIONS - INCHES							WEIGHT (POUNDS)							
		AAC	ACSR	A	B	C	D	J	T	E								
AFNC3-13-4A	1	#4 - 266 MCM	#4 - 4/0 STR	CONTACT FACTORY FOR DETAILS														
AFNC3-13-4B																		
AFNC3-20-4A	1	4/0 - 500 MCM	4/0 - 397 MCM								CONTACT FACTORY FOR DETAILS							
AFNC3-20-4B																		
AFNC3-24-4A	1	350 - 650 MCM	336 - 556 MCM	8-7/8	4	3-5/8	5/8	1/2	5/8	2-1/2								4.60
AFNC3-24-4B				9-3/8	4	4	1-1/8	1/2	5/8	2-1/2								4.60
AFNC3-34-4B	1	500 - 1000 MCM	477 - 795 MCM	8-7/8	4	4	1	1/2	3/4	2-5/8	4.90							
AFNC3-39-4B	1	874 - 1300 MCM	715 - 1113 MCM	10-7/16	4-1/4	4	1-1/8	1/2	1	2-13/16	9.00							
AFNC3-39-6B	2			10-9/16	4-1/4	6	1-1/8	1/2	7/8	2-13/16	10.80							
AFNC3-43-4B	1	1250 - 1590 MCM	1113 - 1431 MCM	10-1/4	4-1/2	4	1-1/8	5/8	13/16	3-1/4	9.60							
AFNC3-43-6B	2			CONTACT FACTORY FOR DETAILS														
AFNC3-49-4B	1	1500 - 2000 MCM	1272 - 1590 MCM	10-15/16	4-3/4	4	1-1/8	5/8	1-1/4	4	18.20							
AFNC3-49-6B	2			10-15/16	4-3/4	6	1-1/8	5/8	1-1/4	4	18.80							
AFNC3-56-4B*	1	2000 - 3500 MCM	1780 - 3064 MCM	11-5/8	6	4	1-1/8	5/8	1-1/4	4-5/8	20.00							
AFNC3-56-6B*	2			11-5/8	6	6	1-1/8	5/8	1-1/4	4-5/8	22.00							
AFNC3-1139-4B	1	4/0 - 1351.5 MCM	4/0 - 1272 (45/7) MCM	10-7/16	4-1/4	4	1-1/8	1/2	1	2-13/16	9.80							
AFNC3-1139-6B	2			10-9/16	4-1/4	6	1-1/8	1/2	7/8	2-13/16	10.15							
AFNC3-3653-4B	1	1100 - 2500 MCM	1113 - 2300 MCM	CONTACT FACTORY FOR DETAILS														
AFNC3-3653-6B	2			CONTACT FACTORY FOR DETAILS														

* Six clamping bolts per cap

SEFCOR

Return To Index

ALUMINUM TERMINALS

TYPE AFNC90

90° Bolted
Cable to Flat Pad

Aluminum alloy terminal with hex head clamping bolts for connecting aluminum cable to flat pad at a 90° angle. Clamping bolts have hex-stops for one-wrench installation. Flat pads have NEMA drilling. Contact sealant is recommended. Also available with other angle flat pad. Wide cable ranges using reversible caps are available and are listed at the end of the table.

Casting Alloy: 356-T6 Aluminum
Clamping Hardware: Aluminum Alloy
Options: See Page 89

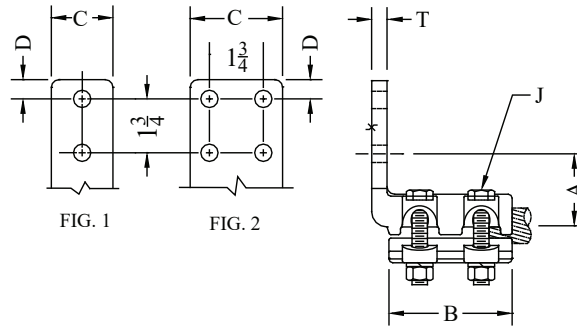

CATALOG NUMBER	FIG. NO.	CONDUCTOR RANGE		DIMENSIONS - INCHES						WEIGHT (POUNDS)
		AAC	ACSR	A	B	C	D	J	T	
AFNC90-13-2B	1	#4 - 266 MCM	#4 - 4/0 STR	1-1/4	3	2	5/8	1/2	3/8	1.00
AFNC90-13-4A	2			1-1/2	3	3	5/8	1/2	3/8	1.25
AFNC90-13-4B	2			3	3	4	1-1/8	1/2	3/8	1.95
AFNC90-20-2B	1	4/0 - 500 MCM	4/0 - 397 MCM	1-5/8	3-1/2	2	5/8	1/2	3/8	1.55
AFNC90-20-4A	2			1-5/8	3-1/2	3	5/8	1/2	3/8	1.55
AFNC90-20-4B	2			2	3-1/2	4	1-1/8	1/2	3/8	1.80
AFNC90-24-2B	1	350 - 650 MCM	336 - 556 MCM	1-3/4	4	2	5/8	1/2	3/8	1.70
AFNC90-24-4A	2			1-13/16	4	3	5/8	1/2	3/8	1.80
AFNC90-24-4B	2			2-5/16	4	4	1-1/8	1/2	3/8	2.40
AFNC90-34-2B	1	556-1000 MCM	477 - 795 MCM	2	4	2	5/8	1/2	7/16	1.80
AFNC90-34-4A	2			2-1/4	4	3	5/8	1/2	9/16	2.05
AFNC90-34-4B	2			2-1/4	4	4	1-1/8	1/2	3/8	2.30
AFNC90-39-2B	1	900 - 1300 MCM	715 - 1113 MCM	2	4-1/4	2	5/8	1/2	1/2	2.35
AFNC90-39-4A	2			2	4-1/4	3	5/8	1/2	1/2	2.35
AFNC90-39-4B	2			2-5/8	4-1/4	4	1-1/8	1/2	1/2	2.60
AFNC90-43-2B	1	1250-1600 MCM	1113 - 1431 MCM	2-1/8	4-1/2	2	5/8	5/8	9/16	2.40
AFNC90-43-4A	2			2-1/8	4-1/2	3	5/8	5/8	9/16	2.40
AFNC90-43-4B	2			2-5/8	4-1/2	4	1-1/8	5/8	5/8	3.40
AFNC90-46-2B	1	1250-1800 MCM	1113-1590 MCM	2-3/8	4-3/4	2	5/8	5/8	7/8	3.90
AFNC90-46-4A	2			2-3/8	4-3/4	3	5/8	5/8	7/8	3.90
AFNC90-46-4B	2			3-1/2	4-3/4	4	1-1/8	5/8	3/4	3.40
AFNC90-49-2B	1	1500-2000 MCM	1272-1590 MCM	2-5/8	4-3/4	2	5/8	5/8	5/8	4.60
AFNC90-49-4A	2			2-5/8	4-3/4	3	5/8	5/8	5/8	4.60
AFNC90-49-4B	2			2-7/8	4-3/4	4	1-1/8	5/8	5/8	4.60
AFNC90-56-4B*	2	2000 - 3500 MCM	2034 - 3064 MCM	3-5/8	6	4	1-1/8	5/8	3/4	6.05
AFNC90-1139-2B	1	4/0 - 1431 MCM	4/0 - 1272 MCM	2	4-1/4	2	5/8	1/2	1/2	2.60
AFNC90-1139-4A	2			2	4-1/4	3	5/8	1/2	1/2	2.60
AFNC90-1139-4B	2			2-5/8	4-1/4	4	1-1/8	1/2	1/2	2.85
AFNC90-3653-4B	2	1100 - 2500 MCM	1113 - 2300 MCM	CONTACT FACTORY FOR DETAILS						

* Six clamping bolts per cap

SEFCOR

ALUMINUM TERMINALS

TYPE AFNT

Straight Bolted
Pipe to Flat Pad

Aluminum alloy terminal with hex head clamping bolts for connecting aluminum pipe to flat pad. Side formed tongues. Clamping bolts have hex stops for one-wrench installation. Flat pads have NEMA drilling. Contact sealant is recommended.

Casting Alloy: 356-T6 Aluminum
Clamping Hardware: Aluminum Alloy
Options: See Page 89

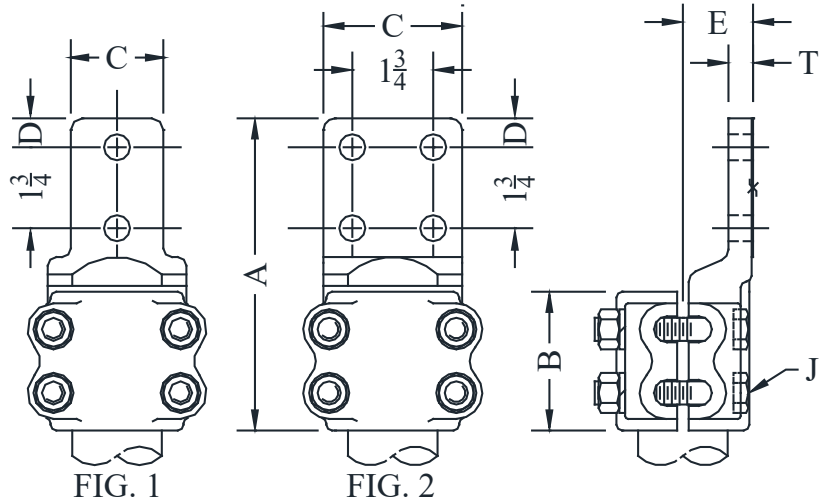

CATALOG NUMBER	FIG. NO.	PIPE SIZE (NPS)	DIMENSIONS - INCHES							WEIGHT (POUNDS)
			A	B	C	D	E	J	T	
AFNT-21-2B	1	1/2	7-1/8	3-3/4	2	5/8	7/8	1/2	3/8	1.25
AFNT-21-4A	2		7	3-3/4	3	5/8	13/16	1/2	5/16	1.50
AFNT-30-2B	1	3/4	6-1/8	2-3/8	2	5/8	1-1/8	1/2	3/8	1.55
AFNT-30-4A	2		5-7/8	2-3/8	3	5/8	1-1/8	1/2	3/8	1.55
AFNT-30-4B	2		8-1/2	4	4	1-1/8	1-1/8	1/2	3/8	2.35
AFNT-39-2B	1	1	6-1/2	3	2	5/8	1-1/4	1/2	7/16	1.55
AFNT-39-4A	2		6-5/8	3	3	5/8	1-1/4	1/2	7/16	1.55
AFNT-39-4B	2		7-5/8	3	4	1-1/8	1-1/4	1/2	7/16	1.55
AFNT-49-2B	1	1-1/4	6-5/8	3	2	5/8	1-3/8	1/2	9/16	1.85
AFNT-49-4A	2		6-1/2	3	3	5/8	1-3/8	1/2	3/8	1.85
AFNT-49-4B	2		7-5/8	3	4	1-1/8	1-1/2	1/2	3/8	1.85
AFNT-53-2B	1	1-1/2	6-7/8	3-1/8	2	5/8	1-1/2	1/2	1/2	2.10
AFNT-53-4A	2		6-7/8	3-1/8	3	5/8	1-1/2	1/2	1/2	2.60
AFNT-53-4B	2		7-5/8	3-1/8	4	1-1/8	1-1/2	1/2	7/16	2.85
AFNT-58-2B	1	2	7-1/4	3-1/2	2	5/8	1-3/4	1/2	9/16	2.60
AFNT-58-4A	2		7-1/4	3-1/2	3	5/8	1-3/4	1/2	9/16	2.85
AFNT-58-4B	2		8-1/8	3-1/2	4	1-1/8	1-3/4	1/2	9/16	3.10
AFNT-60-2B	1	2-1/2	7-3/4	3-1/2	2	5/8	2-1/8	1/2	5/8	2.60
AFNT-60-4A	2		7-3/8	3-1/2	3	5/8	2-1/16	1/2	11/16	3.35
AFNT-60-4B	2		8-1/4	3-1/2	4	1-1/8	2	1/2	11/16	3.85
AFNT-62-2B	1	3	7-7/8	4	2	5/8	2-1/2	5/8	7/8	5.50
AFNT-62-4A	2		7-7/8	4	3	5/8	2-1/2	5/8	7/8	5.50
AFNT-62-4B	2		9	4	4	1-1/8	2-1/2	5/8	7/8	6.25

ALUMINUM TERMINALS

TYPE AFNT- Continued

CATALOG NUMBER	FIG. NO.	PIPE SIZE (NPS)	DIMENSIONS - INCHES							WEIGHT (POUNDS)
			A	B	C	D	E	J	T	
AFNT-63-2B	1	3-1/2	8-3/8	4-3/8	2	5/8	2-5/8	5/8	1	6.75
AFNT-63-4A	2		8-3/8	4-3/8	3	5/8	2-5/8	5/8	1	6.75
AFNT-63-4B	2		9-1/4	4-3/8	4	1-1/8	2-5/8	5/8	7/8	7.00
AFNT-64-2B	1	4	8-3/8	5-3/8	2	5/8	3	5/8	1	8.25
AFNT-64-4A	2		8-3/8	4-1/2	3	5/8	3	5/8	1	8.25
AFNT-64-4B	2		9-3/8	4-1/2	4	1-1/8	2-7/8	5/8	1	8.25
AFNT-67-4A*	2	5	11-5/16	7	3	5/8	3-5/8	5/8	1-1/4	17.55
AFNT-67-4B*	2		12-3/8	7	4	1-1/8	3-5/8	5/8	1-1/4	17.55
AFNT-69-4A*	2	6	11-3/4	7	3	5/8	4-3/16	5/8	1	21.05
AFNT-69-4B*	2		12-3/4	7	4	1-1/8	4-3/16	5/8	1	21.05

*Six Conductor-Clamping Bolts

ALUMINUM TERMINALS

TYPE AFNT90

90° Bolted
Pipe to Flat Pad

Aluminum alloy terminal with hex head clamping bolts for connecting aluminum pipe to flat pad at a 90° angle. Clamping bolts have hex stops for one-wrench installation. Flat pads have NEMA drilling. Contact sealant is recommended. Angle connector may be obtained by specifying the desired angle.

Casting Alloy: 356-T6 Aluminum
Clamping Hardware: Aluminum Alloy
Options: See Page 89

EXAMPLE: AFNT45-21-4A

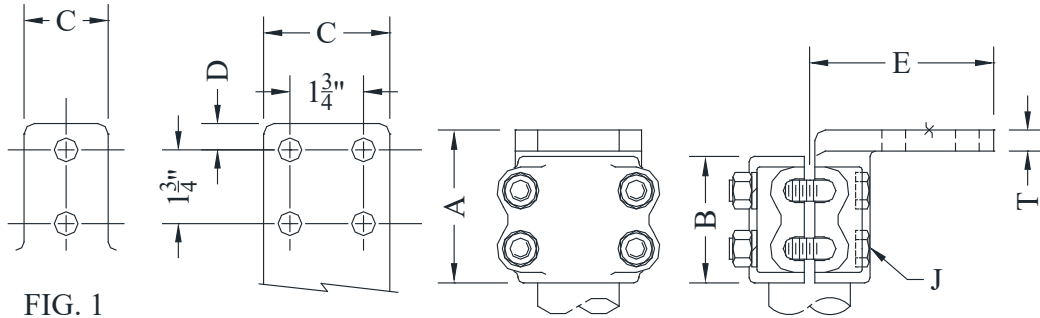

FIG. 1

FIG. 2

CATALOG NUMBER	FIG. NO.	PIPE SIZE (NPS)	DIMENSIONS - INCHES							WEIGHT (POUNDS)
			A	B	C	D	E	J	T	
AFNT90-21-2B	1	1/2	4-1/8	3-3/4	2	5/8	4-1/8	1/2	13/32	1.25
AFNT90-21-4A	2		4-9/16	4	3	5/8	4-5/8	1/2	9/16	1.50
AFNT90-30-2B	1	3/4	2-15/16	2-3/8	2	5/8	4-1/16	1/2	3/8	1.30
AFNT90-30-4A	2		2-15/16	2-3/8	3	5/8	4-1/4	1/2	3/8	1.80
AFNT90-30-4B	2		4-7/16	4	4	1-1/8	5	1/2	3/8	2.00
AFNT90-39-2B	1	1	3-1/2	3	2	5/8	4-1/8	1/2	1/2	1.55
AFNT90-39-4A	2		3-1/2	3	3	5/8	4-1/16	1/2	7/16	1.55
AFNT90-39-4B	2		3-1/2	3	4	1-1/8	5-9/16	1/2	1/2	2.40
AFNT90-49-2B	1	1-1/4	3-1/2	3	2	5/8	4-5/8	1/2	7/16	2.35
AFNT90-49-4A	2		4-3/4	4-1/4	3	5/8	4-3/8	1/2	1/2	2.85
AFNT90-49-4B	2		3-1/2	3	4	1-1/8	5-1/8	1/2	7/16	2.35
AFNT90-53-2B	1	1-1/2	3-5/8	3	2	5/8	4-3/8	1/2	1/2	2.35
AFNT90-53-4A	2		3-5/8	3	3	5/8	4-3/8	1/2	1/2	2.35
AFNT90-53-4B	2		3-5/8	3	4	1-1/8	5-3/8	1/2	1/2	2.85
AFNT90-58-2B	1	2	4-1/16	3-1/2	2	5/8	4-5/8	1/2	9/16	2.60
AFNT90-58-4A	2		4-1/16	3-1/2	3	5/8	4-5/8	1/2	9/16	2.60
AFNT90-58-4B	2		4-3/16	3-1/2	4	1-1/8	5-3/8	1/2	9/16	3.10
AFNT90-60-2B	1	2-1/2	4-1/4	3-1/2	2	5/8	5-1/8	1/2	11/16	3.35
AFNT90-60-4A	2		4-1/4	3-1/2	3	5/8	5-1/8	1/2	11/16	3.35
AFNT90-60-4B	2		4-5/16	3-1/2	4	1-1/8	5-3/4	1/2	11/16	3.85
AFNT90-62-2B	1	3	4-7/8	4	2	5/8	5-1/2	5/8	3/4	5.75
AFNT90-62-4A	2		4-7/8	4	3	5/8	5-1/2	5/8	3/4	5.75
AFNT90-62-4B	2		4-7/8	4	4	1-1/8	5-7/8	5/8	3/4	5.75

Continued on next page

ALUMINUM TERMINALS

TYPE AFNT90- Continued

CATALOG NUMBER	FIG. NO.	PIPE SIZE (NPS)	DIMENSIONS - INCHES							WEIGHT (POUNDS)
			A	B	C	D	E	J	T	
AFNT90-63-2B	1	3-1/2	5-1/2	4-3/8	2	5/8	5-11/16	5/8	1	7.50
AFNT90-63-4A	2		5-1/2	4-3/8	3	5/8	6-1/8	5/8	1	7.50
AFNT90-63-4B	2		5-1/2	4-3/8	4	1-1/8	6-11/16	5/8	1	7.50
AFNT90-64-2B	1	4	5-5/8	4-1/2	2	5/8	6-1/16	5/8	1	7.75
AFNT90-64-4A	2		5-1/2	4-1/2	3	5/8	6-1/16	5/8	1	7.75
AFNT90-64-4B	2		5-5/8	4-1/2	4	1-1/8	6-11/16	5/8	1	8.50
AFNT90-67-4A*	2	5	8-1/4	6-3/4	3	5/8	7	5/8	1-1/4	17.55
AFNT90-67-4B*	2		8-1/4	6-3/4	4	1-1/8	7-1/2	5/8	1-1/4	17.55
AFNT90-69-4A*	2	6	9-3/8	7	3	5/8	8-9/16	5/8	1-1/2	25.25
AFNT90-69-4B*	2		9-3/8	7	4	1-1/8	9-1/16	5/8	1-1/2	25.25

*Six Conductor-Clamping Bolts

ALUMINUM TERMINALS

TYPE AFNTC

Straight Bolted
Pipe to Flat Pad

Aluminum alloy terminal with hex head clamping bolts for connecting aluminum pipe to flat pad. Center-formed tongues. Clamping bolts have hex stops for one-wrench installation. Contact sealant is recommended.

Casting Alloy: 356-T6 Aluminum
Clamping Hardware: Aluminum Alloy
Options: See Page 89

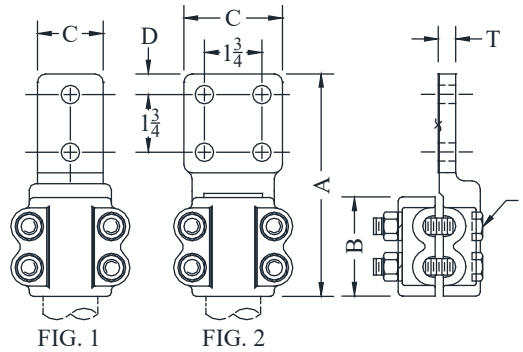

CATALOG NUMBER	FIG. NO.	PIPE SIZE (NPS)	DIMENSIONS - INCHES						WEIGHT (POUNDS)
			A	B	C	D	J	T	
AFNTC-30-2B	1	3/4	7-5/8	4	2	5/8	1/2	3/8	1.45
AFNTC-30-4A	2		7-7/8	4	3	5/8	1/2	3/8	1.85
AFNTC-30-4B	2		8-7/8	4	4	1-1/8	1/2	3/8	2.10
AFNTC-39-2B	1	1	6-1/2	3	2	5/8	1/2	1/2	1.55
AFNTC-39-4A	2		6-1/2	3	3	5/8	1/2	7/16	1.85
AFNTC-39-4B	2		8	3	4	1-1/8	1/2	1/2	2.40
AFNTC-49-2B	1	1-1/4	6-3/4	3	2	5/8	1/2	9/16	2.10
AFNTC-49-4A	2		6-3/4	3	3	5/8	1/2	9/16	1.85
AFNTC-49-4B	2		7-7/16	3	4	1-1/8	1/2	1/2	2.35
AFNTC-53-2B	1	1-1/2	6-7/8	3-1/8	2	5/8	1/2	1/2	2.10
AFNTC-53-4A	2		6-3/4	3-1/8	3	5/8	1/2	1/2	2.35
AFNTC-53-4B	2		8-1/8	3-1/8	4	1-1/8	1/2	1/2	3.25
AFNTC-58-2B	1	2	7-3/8	3-1/2	2	5/8	1/2	9/16	3.10
AFNTC-58-4A	2		7-3/8	3-1/2	3	5/8	1/2	9/16	3.10
AFNTC-58-4B	2		8-1/8	3-1/2	4	1-1/8	1/2	1/2	3.35
AFNTC-60-2B	1	2-1/2	7-1/4	3-1/2	2	5/8	1/2	11/16	3.35
AFNTC-60-4A	2		7-3/16	3-1/2	3	5/8	1/2	11/16	3.35
AFNTC-60-4B	2		8-5/16	3-1/2	4	1-1/8	1/2	11/16	3.35
AFNTC-62-2B	1	3	7-7/8	4	2	5/8	5/8	7/8	5.75
AFNTC-62-4A	2		7-7/8	4	3	5/8	5/8	7/8	5.75
AFNTC-62-4B	2		9-3/16	4	4	1-1/8	5/8	7/8	6.25
AFNTC-63-2B	1	3-1/2	8	4-3/8	2	5/8	5/8	1	7.00
AFNTC-63-4A	2		8	4-3/8	3	5/8	5/8	1	7.00
AFNTC-63-4B	2		8-7/8	4-3/8	4	1-1/8	5/8	1	7.50
AFNTC-64-2B	1	4	8-5/8	4-1/2	2	5/8	5/8	1	8.00
AFNTC-64-4A	2		8-5/8	4-1/2	3	5/8	5/8	1	8.00
AFNTC-64-4B	2		9-1/2	4-1/2	4	1-1/8	5/8	1	8.50
AFNTC-67-4A*	2	5	11-1/8	7	3	5/8	5/8	1-1/4	17.55
AFNTC-67-4B*	2		12-1/8	7	4	1-1/8	5/8	1-1/4	17.55
AFNTC-69-4A*	2	6	11-3/8	7	3	5/8	5/8	1-1/2	20.55
AFNTC-69-4B*	2		12-3/8	7	4	1-1/8	5/8	1-1/2	20.55

*Six Conductor-Clamping Bolts

SEFCOR

ALUMINUM TERMINALS

TYPE AFXT

Expansion Terminal
Pipe to Flat Pad

Casting Alloy: 356-T6 Aluminum
Laminated Straps: 1100-0 Aluminum
Hardware: Aluminum Alloy
Options: See Page 89

Aluminum bolted expansion terminal with hex head clamping bolts for aluminum pipe to flat pad. Center-formed tongues.
Guides are sized for use with standard SCH 40 pipe.
Clamping bolts have hex stops for one-wrench installation.
Flat pads have NEMA drilling. Contact sealant is recommended.
Add suffix (H) to catalog number for SCH 80 pipe. Example: AFXT-60H-4A

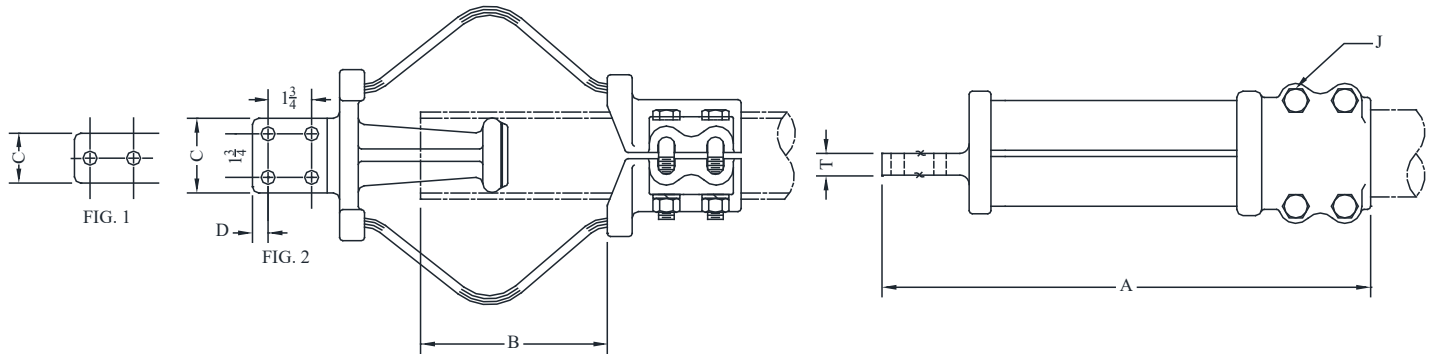

CATALOG NUMBER	FIG. NO.	PIPE SIZE (NPS)	DIMENSIONS - INCHES						WEIGHT (POUNDS)
			A	B	C	D	J	T	
AFXT-39-2B	1	1	14	4-3/8	2	5/8	1/2	3/8	3.65
AFXT-39-4A	2		14	4-3/8	3	5/8	1/2	3/8	3.55
AFXT-39-4B	2		15	4-3/8	4	1-1/8	1/2	3/8	4.30
AFXT-49-2B	1	1-1/4	15-13/16	5	2	5/8	1/2	3/4	5.60
AFXT-49-4A	2		15-3/4	5	3	5/8	1/2	3/4	6.35
AFXT-49-4B	2		16-1/4	5	4	1-1/8	1/2	1/2	7.10
AFXT-53-2B	1	1-1/2	15-3/4	5-1/8	2	5/8	1/2	5/8	5.10
AFXT-53-4A	2		15-1/8	5-1/8	3	5/8	1/2	5/8	5.10
AFXT-53-4B	2		16-1/2	5-1/8	4	1-1/8	1/2	5/8	5.35
AFXT-58-2B	1	2	15-7/8	5	2	5/8	1/2	11/16	7.50
AFXT-58-4A	2		16	5	3	5/8	1/2	11/16	7.50
AFXT-58-4B	2		17-1/4	5	4	1-1/8	1/2	1/2	7.75
AFXT-60-2B	1	2-1/2	18-1/2	7	2	5/8	1/2	5/8	11.75
AFXT-60-4A	2		18-1/2	7	3	5/8	1/2	11/16	11.75
AFXT-60-4B	2		19-5/8	7	4	1-1/8	1/2	5/8	11.75
AFXT-62-2B	1	3	19-5/8	7-1/2	2	5/8	5/8	11/16	15.10
AFXT-62-4A	2		19-5/8	7-1/2	3	5/8	5/8	11/16	15.10
AFXT-62-4B	2		20-1/8	7-1/2	4	1-1/8	5/8	7/8	15.85
AFXT-63-4A	2	3-1/2	20-1/4	7-3/4	3	5/8	5/8	7/8	18.40
AFXT-63-4B	2		21-3/16	7-13/16	4	1-1/8	5/8	7/8	18.40
AFXT-64-4A	2	4	20-1/2	8-1/4	3	5/8	5/8	3/4	20.00
AFXT-64-4B	2		21-1/4	8-1/4	4	1-1/8	5/8	1	20.70
AFXT-67-4A*	2	5	22-1/2	7	3	5/8	5/8	1-1/8	36.70
AFXT-67-4B*	2		23-1/2	7	4	1-1/8	5/8	1-1/8	36.70
AFXT-69-4B*	2	6	23-7/8	7	4	1-1/8	5/8	1-1/4	45.10

*Six Conductor-Clamping Bolts

SEFCOR

Return To Index

ALUMINUM TERMINALS

TYPE AFXT-V

Expansion Terminal
Pipe to Flat Pad

Casting Alloy: 356-T6 Aluminum
Laminated Straps: 1100-0 Aluminum
Hardware: Aluminum Alloy
Options: See Page 89

Aluminum bolted expansion terminal with hex head clamping bolts for aluminum pipe to flat pad. Center-formed tongues.
Guides are sized for use with standard SCH 40 tubing.
Clamping bolts have hex stops for one-wrench installation.
Flat pads have NEMA drilling. Contact sealant is recommended.
Add suffix (H) to catalog number for SCH 80 pipe. Example: AFXT-V-60H-4A

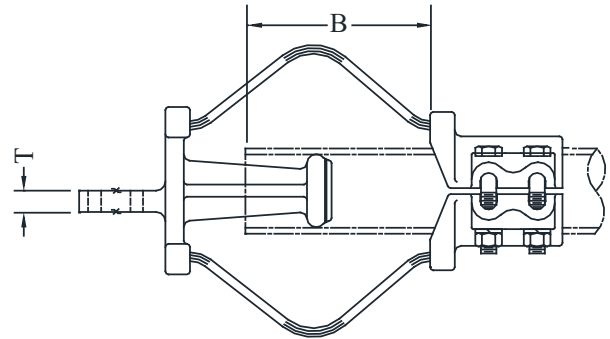
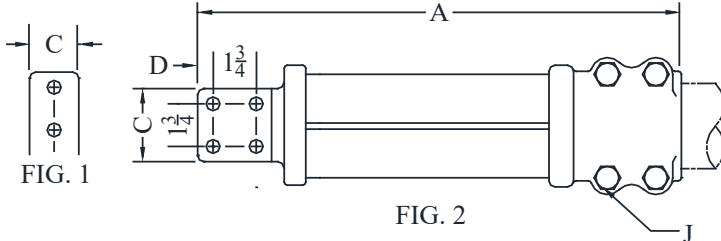

CATALOG NUMBER	FIG. NO.	PIPE SIZE (NPS)	DIMENSIONS - INCHES						WEIGHT (POUNDS)
			A	B	C	D	J	T	
AFXT-V-30-2B	1	3/4	12-1/2	4-1/2	2	5/8	1/2	3/8	2.40
AFXT-V-30-4A	2		12-1/2	4-1/2	3	5/8	1/2	3/8	2.60
AFXT-V-30-4B	2		13-1/2	4-1/2	4	1-1/8	1/2	3/8	2.90
AFXT-V-39-2B	1	1	14	4-3/4	2	5/8	1/2	1/2	3.82
AFXT-V-39-4A	2		14	4-3/4	3	5/8	1/2	1/2	3.82
AFXT-V-39-4B	2		15	4-3/4	4	1-1/8	1/2	1/2	4.00
AFXT-V-49-2B	1	1-1/4	15-1/2	5	2	5/8	1/2	5/8	5.10
AFXT-V-49-4A	2		15-1/2	5	3	5/8	1/2	5/8	5.05
AFXT-V-49-4B	2		17-1/8	5	4	1-1/8	1/2	1/2	6.05
AFXT-V-53-2B	1	1-1/2	15-1/8	5-1/8	2	5/8	1/2	5/8	5.35
AFXT-V-53-4A	2		15-1/8	5-1/8	3	5/8	1/2	5/8	5.35
AFXT-V-53-4B	2		16-1/8	5-1/8	4	1-1/8	1/2	5/8	5.60
AFXT-V-58-2B	1	2	16	5	2	5/8	1/2	9/16	7.00
AFXT-V-58-4A	2		16	5	3	5/8	1/2	9/16	7.00
AFXT-V-58-4B	2		16-7/8	5	4	1-1/8	1/2	1/2	7.25
AFXT-V-60-2B	1	2-1/2	19-1/8	7	2	5/8	1/2	5/8	11.75
AFXT-V-60-4A	2		18-1/2	7	3	5/8	1/2	5/8	11.75
AFXT-V-60-4B	2		19-1/2	7	4	1-1/8	1/2	5/8	14.25
AFXT-V-62-2B	1	3	19-1/4	7-1/4	2	5/8	5/8	5/8	15.35
AFXT-V-62-4A	2		19-1/4	7-1/4	3	5/8	5/8	5/8	15.35
AFXT-V-62-4B	2		20-5/8	7-1/2	4	1-1/8	5/8	3/4	15.35
AFXT-V-63-4A	2	3-1/2	20-1/4	7-3/4	3	5/8	5/8	3/4	18.40
AFXT-V-63-4B	2		21-5/16	7-13/16	4	1-1/8	5/8	7/8	18.40
AFXT-V-64-4A	2	4	20-1/2	8-1/4	3	5/8	5/8	7/8	20.20
AFXT-V-64-4B	2		21-1/2	8-1/4	4	1-1/8	5/8	7/8	20.20
AFXT-V-67-4A*	2	5	22-1/2	8-1/2	3	5/8	5/8	1-1/8	36.45
AFXT-V-67-4B*	2		23-1/2	8-1/2	4	1-1/8	5/8	1-1/8	36.45
AFXT-V-69-4B*	2	6	23-7/8	9	4	1-1/8	5/8	1-1/4	46.40

*Six Conductor-Clamping Bolts

SEFCOR

Return To Index

ALUMINUM TERMINALS

TYPE AFXTO

Expansion Terminal
Pipe to Flat Pad

Casting Alloy: 356-T6 Aluminum
Laminated Straps: 1100-0 Aluminum
Hardware: Aluminum Alloy
Options: See Page 89

Aluminum bolted expansion terminal with hex head clamping bolts for aluminum pipe to flat pad. Side formed tongues.
Guides are sized for use with standard SCH 40 pipe.
Clamping bolts have hex stops for one-wrench installation.
Flat pads have NEMA drilling. Contact sealant is recommended.
Add suffix (H) to catalog number for SCH 80 pipe. Example: AFXTO-58H-4A

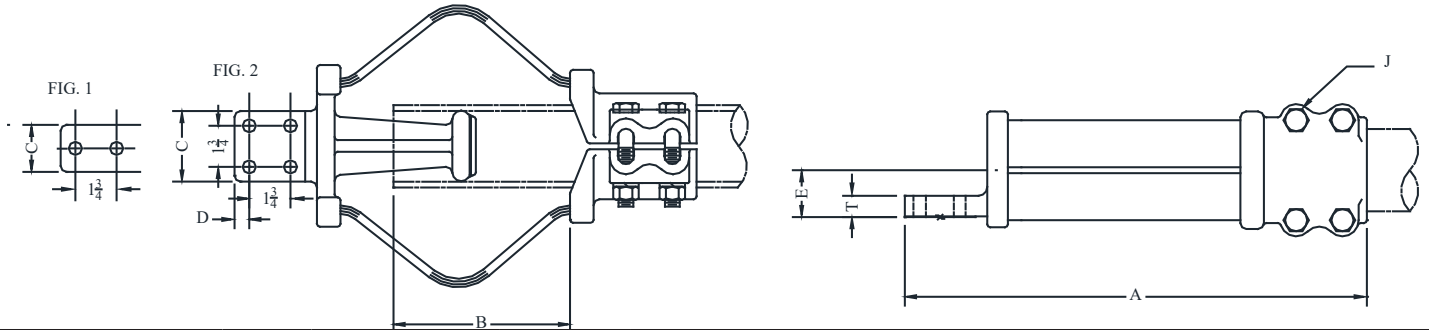

CATALOG NUMBER	FIG. NO.	PIPE SIZE (NPS)	DIMENSIONS - INCHES							WEIGHT (POUNDS)
			A	B	C	D	E	J	T	
AFXTO-39-2B	1	1	14	4-1/16	2	5/8	1-3/8	1/2	3/8	3.90
AFXTO-39-4A	2		14	4-1/16	3	5/8	1-3/8	1/2	3/8	4.05
AFXTO-39-4B	2		15	4-1/16	4	1-1/8	1-3/8	1/2	3/8	5.00
AFXTO-49-2B	1	1-1/4	15-1/4	5-1/8	2	5/8	1-1/2	1/2	1/2	6.60
AFXTO-49-4A	2		15-1/4	5-1/8	3	5/8	1-1/2	1/2	1/2	6.90
AFXTO-49-4B	2		16-1/4	5	4	1-1/8	1-1/2	1/2	1/2	7.10
AFXTO-53-2B	1	1-1/2	15-3/4	5-1/8	2	5/8	1-1/2	1/2	5/8	4.80
AFXTO-53-4A	2		15-1/8	5-1/8	3	5/8	1-1/2	1/2	5/8	4.85
AFXTO-53-4B	2		16-1/2	5-1/8	4	1-1/8	1-1/2	1/2	1/2	6.35
AFXTO-58-2B	1	2	15-7/8	5	2	5/8	1-3/4	1/2	1/2	6.75
AFXTO-58-4A	2		15-7/8	5	3	5/8	1-3/4	1/2	1/2	7.00
AFXTO-58-4B	2		17-1/4	5	4	1-1/8	1-3/4	1/2	1/2	7.00
AFXTO-60-2B	1	2-1/2	18-1/2	7	2	5/8	2	1/2	11/16	11.75
AFXTO-60-4A	2		18-1/2	7	3	5/8	2	1/2	11/16	11.75
AFXTO-60-4B	2		19-1/2	7	4	1-1/8	2	1/2	3/4	12.50
AFXTO-62-2B	1	3	19-5/8	7-1/2	2	5/8	2	5/8	7/8	14.85
AFXTO-62-4A	2		19-5/8	7-1/2	3	5/8	2	5/8	7/8	14.85
AFXTO-62-4B	2		20-1/8	7-1/2	4	1-1/8	2-1/2	5/8	7/8	15.85
AFXTO-63-4A	2	3-1/2	20-1/4	7-3/4	3	5/8	2-5/8	5/8	7/8	19.40
AFXTO-63-4B	2		21-1/4	7-3/4	4	1-1/8	2-5/8	5/8	11/16	19.40
AFXTO-64-4A	2	4	20-1/2	8-1/4	3	5/8	2-7/8	5/8	7/8	20.00
AFXTO-64-4B	2		21-1/4	8-1/4	4	1-1/8	2-7/8	5/8	1	20.70
AFXTO-67-4A*	2	5	23-1/8	7	3	5/8	3-5/8	5/8	1	38.70
AFXTO-67-4B*	2		24-1/8	7	4	1-1/8	3-5/8	5/8	1	38.70
AFXTO-69-4A*	2	6	23-1/2	6-1/2	3	5/8	4	5/8	1	47.10
AFXTO-69-4B*	2		24-1/2	6-1/2	4	1-1/8	4	5/8	1-1/4	47.10

*Six Conductor-Clamping Bolts

SEFCOR

ALUMINUM TERMINALS

TYPE ASFFT

Expansion
Pipe to Flat Pad

Aluminum semi-flexible terminal with hex head clamping bolts for connecting aluminum pipe to flat. Aluminum pad surface is coated with contact sealant and factory bolted to laminated strap. Clamping bolts have hex-stops for one-wrench installation. Flat pad on laminated strap has NEMA drilling. Contact sealant is recommended. Contact pads are tin plated.
NOTE: This connector is not recommended as a support member.

Casting Alloy: 356-T6 Aluminum
Laminated Straps: Copper
Hardware: Aluminum Alloy
Strap Mounting Hardware: Stainless Steel
Options: See Page 89

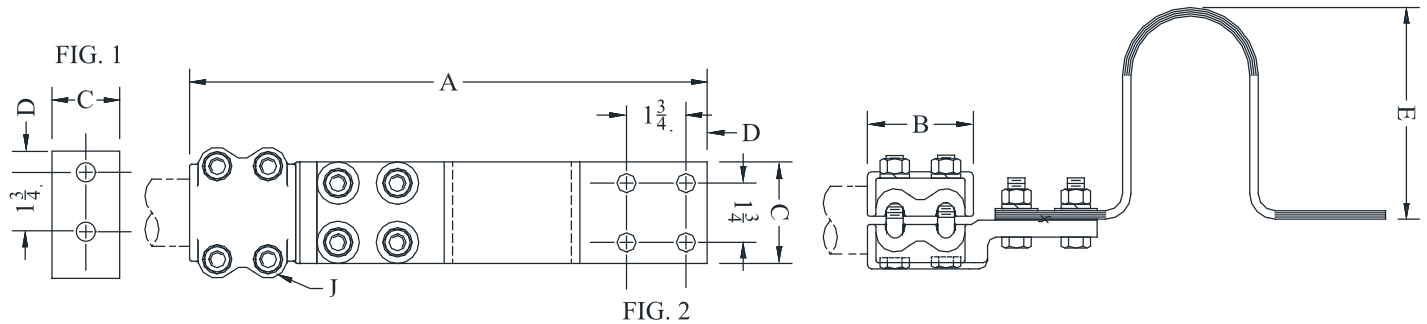

CATALOG NUMBER	FIG. NO.	PIPE SIZE (NPS)	DIMENSIONS - INCHES						WEIGHT (POUNDS)
			A	B	C	D	E	J	
ASFFT-30-2B	1	3/4	15-7/8	4	2	5/8	6-1/2	1/2	5.30
ASFFT-30-4A	2		14-3/8	2-3/8	3	5/8	6-1/4	1/2	7.75
ASFFT-39-2B	1	1	15	3	2	5/8	6-1/4	1/2	5.30
ASFFT-39-4A	2		15	3	3	5/8	6-1/4	1/2	7.75
ASFFT-49-2B	1	1-1/4	16	3	2	5/8	6-1/4	1/2	9.85
ASFFT-49-4A	2		15-7/8	3	3	5/8	6-1/4	1/2	9.85
ASFFT-53-2B	1	1-1/2	15-1/2	3-1/8	2	5/8	6-3/8	1/2	9.75
ASFFT-53-4A	2		15-1/4	3-1/8	3	5/8	6-1/4	1/2	8.30
ASFFT-53-4B	2		15-1/4	3-1/8	4	1-1/8	6-1/4	1/2	10.50
ASFFT-58-2B	1	2	16-1/2	3-1/2	2	5/8	7-3/8	1/2	12.65
ASFFT-58-4A	2		16-1/8	3-1/2	3	5/8	7	1/2	13.00
ASFFT-58-4B	2		17-3/4	3-1/2	4	1-1/8	5-3/4	1/2	14.80
ASFFT-60-2B	1	2-1/2	16-1/4	3-1/2	2	5/8	7-1/4	1/2	15.80
ASFFT-60-4A	2		16-1/2	3-1/2	3	5/8	7-1/4	1/2	15.80
ASFFT-60-4B	2		18-7/8	3-1/2	4	1-1/8	5-3/8	1/2	21.80
ASFFT-62-2B	1	3	16-5/8	4	2	5/8	7	5/8	16.75
ASFFT-62-4A	2		16-7/8	4	3	5/8	7-1/4	5/8	18.25
ASFFT-62-4B	2		19-1/8	4	4	1-1/8	8-1/2	5/8	29.70
ASFFT-63-4A	2	3-1/2	17-3/4	4-3/8	3	5/8	7-1/2	5/8	23.15
ASFFT-63-4B	2		19-1/2	4-3/8	4	1-1/8	8-1/2	5/8	31.00
ASFFT-64-4A	2	4	18-3/8	4-1/2	3	5/8	7-1/2	5/8	24.05
ASFFT-64-4B	2		19-3/4	4-1/2	4	1-1/8	8-1/2	5/8	32.00
ASFFT-67-4B*	2	5	23	6-3/4	4	1-1/8	8-1/8	5/8	52.70

*Six Conductor-Clamping Bolts

SEFCOR

ALUMINUM TERMINALS

TYPE ASFFT90

Expansion
Pipe to Flat Pad

Aluminum semi-flexible terminal with hex head clamping bolts for connecting aluminum pipe to flat. Aluminum pad surface is coated with contact sealant and factory bolted to laminated strap. Clamping bolts have hex-stops for one-wrench installation. Flat pad on laminated strap has NEMA drilling.

Contact sealant is recommended. Contact pads are tin plated.

NOTE: This connector is not recommended as a support member.

Casting Alloy: 356-T6 Aluminum

Laminated Straps: Copper

Clamping Hardware: Aluminum Alloy

Strap Mounting Hardware: Stainless Steel

Options: See Page 89

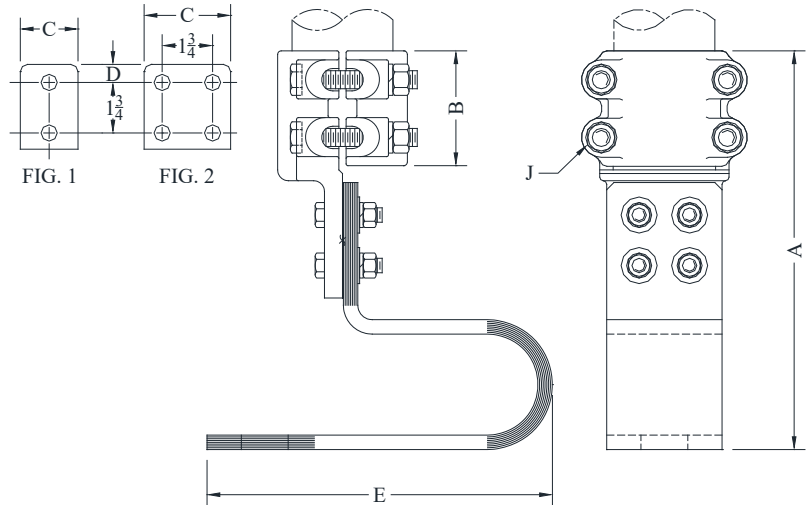

CATALOG NUMBER	FIG. NO.	PIPE SIZE (NPS)	DIMENSIONS - INCHES						WEIGHT (POUNDS)
			A	B	C	D	E	J	
ASFFT90-30-2B	1	3/4	10-3/8	2-3/8	2	5/8	10	1/2	4.75
ASFFT90-30-4A	2		10-5/8	2-3/8	3	5/8	8	1/2	7.40
ASFFT90-39-2B	1	1	11	3	2	5/8	10-1/4	1/2	5.50
ASFFT90-39-4A	2		11-1/2	3	3	5/8	8-1/8	1/2	10.20
ASFFT90-49-2B	1	1-1/4	11-3/4	3	2	5/8	10-1/4	1/2	6.50
ASFFT90-49-4A	2		11-3/4	3	3	5/8	11-9/16	1/2	11.35
ASFFT90-53-2B	1	1-1/2	11-3/4	3-1/8	2	5/8	10-3/8	1/2	7.40
ASFFT90-53-4A	2		11-1/2	3-1/8	3	5/8	11	1/2	8.90
ASFFT90-53-4B	2		12-1/2	3-1/8	4	1-1/8	11	1/2	11.95
ASFFT90-58-2B	1	2	12-1/2	3-1/2	2	5/8	11-1/8	1/2	13.00
ASFFT90-58-4A	2		12-1/2	3-1/2	3	5/8	11-3/16	1/2	12.60
ASFFT90-58-4B	2		12-7/8	3-1/2	4	1-1/8	12-7/8	1/2	16.90
ASFFT90-60-2B	1	2-1/2	12-1/4	3-1/2	2	5/8	11-7/16	1/2	10.75
ASFFT90-60-4A	2		13-7/8	3-1/2	3	5/8	11-7/16	1/2	17.00
ASFFT90-60-4B	2		13-1/16	3-1/2	4	1-1/8	12-7/8	1/2	17.00
ASFFT90-62-2B	1	3	13-3/4	4	2	5/8	12	5/8	27.40
ASFFT90-62-4A	2		13-3/4	4	3	5/8	12	5/8	27.40
ASFFT90-62-4B	2		14-13/16	4	4	1-1/8	12-1/2	5/8	31.30
ASFFT90-63-4A	2	3-1/2	13-7/8	4-3/8	3	5/8	12	5/8	14.50
ASFFT90-63-4B	2		15	4-3/8	4	1-1/8	12-3/4	5/8	30.20
ASFFT90-64-4A	2	4	14-3/8	4-1/2	3	5/8	12-1/2	5/8	25.90
ASFFT90-64-4B	2		15-1/4	4-1/2	4	1-1/8	12-7/8	5/8	30.00
ASFFT90-67-4B	2	5	18-1/4	6-3/4	4	1-1/8	13-1/16	5/8	50.45

ALUMINUM TERMINALS

TYPE ASXR/ASXR 2

Straight Bolted
Cable or Pipe to Flat Pad

Casting Alloy: 356-T6 Aluminum
Clamping Hardware: Aluminum Alloy

Aluminum bolted terminal for aluminum cable or pipe to flat, straight or 90°.

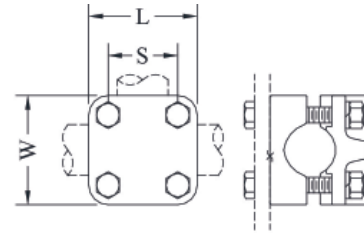

FIG. 1

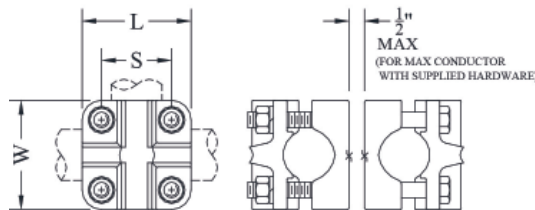

FIG. 2

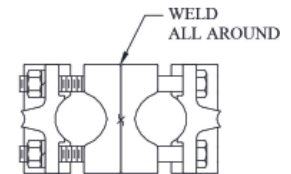

FIG. 3

CATALOG NUMBER	FIG. NO.	CONDUCTOR RANGE		DIMENSIONS - INCHES			WEIGHT (POUNDS)
		CABLE	NPS	L	W	S	
ASXR-48	1	#2 - 2000 MCM	3/8 - 1	3-3/8	3-3/8	2-1/4	2.35
ASXR2-48-NW	2	(2) #2 - 2000 MCM	3/8 - 1	3-3/8	3-3/8	2-1/4	4.10
ASXR2-48	3	(2) #2 - 2000 MCM	3/8 - 1	3-3/8	3-3/8	2-1/4	4.10

TYPE FNXR-AL

Dual Function
Tee Connector/Terminal
Cable or Pipe

Casting Alloy: 356-T6 Aluminum
Clamping Hardware: Aluminum Alloy

Aluminum bolted, dual function Tee/Terminal for cable or pipe connections to flat pad tap. Reversible cap allows a wide range conductor, straight or 90° to a 2 or 4 hole NEMA flat.

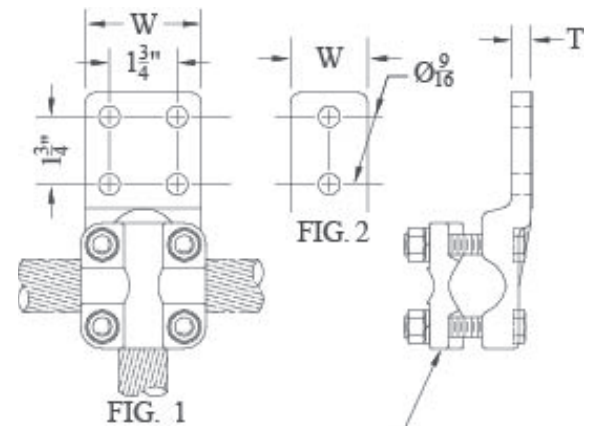

FIG. 1

FIG. 2

CAP MAY BE TURNED OR REVERSED TO CLAMP CONDUCTOR WITHIN RANGE SHOWN.

CATALOG NUMBER	FIG. NO.	W	T	CONDUCTOR RANGE	
				CABLE	NPS
FNXR-0139-2B-AL	2	2	1/2	#8 - 1300 MCM	1/4 - 1
FNXR-0139-4A-AL	1	3	3/8	#8 - 1300 MCM	1/4 - 1
FNXR-0420-2B-AL	2	2	3/8	#4 - 500 MCM	1/4 - 3/8
FNXR-39-2B-AL	2	2	1/2	350 - 1500 MCM	1/2 - 1
FNXR-39-4A-AL	1	3	1/2	350 - 1500 MCM	1/2 - 1
FNXR-48-4A-AL	1	3	3/4	#2 - 2000 MCM	3/8 - 1
FNXR-48-4B-AL	1	4	3/4	#2 - 2000 MCM	3/8 - 1

ALUMINUM TERMINALS

TYPE WFC

Straight Welded
Cable to Flat Pad

Aluminum alloy weldment terminal for connecting aluminum cable to flat pad.
Flat pads have NEMA drilling.
Contact sealant is recommended for contact pad after welding.
Angle connectors may be obtained by specifying the desired angle.
Example: WFC90-34-4A

Casting Alloy: 356-T6 Aluminum
Clamping Hardware: Aluminum Alloy
Options: See Page 89

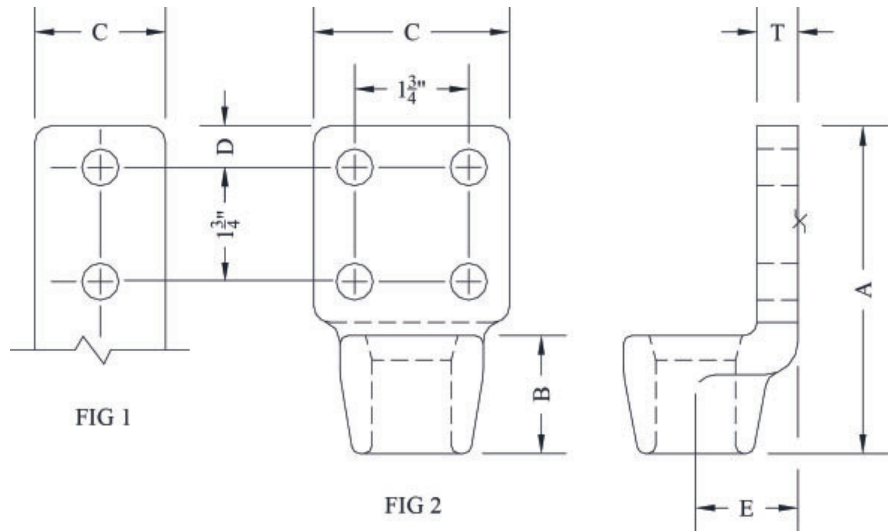

CATALOG NUMBER	FIG. NO.	CONDUCTOR RANGE		DIMENSIONS - INCHES						WEIGHT (POUNDS)
		AAC	ACSR	A	B	C	D	E	T	
WFC-09-2B	1	2/0 MCM	1/0 - 2/0 MCM	4	7/8	2	5/8	21/32	1/4	.35
WFC-09-4A	2			4-1/2	1-1/4	3	5/8	1-1/8	3/8	.50
WFC-10-2B	1	3/0 MCM	-----	4-1/2	1-1/4	2	5/8	1-1/8	3/8	.50
WFC-10-4A	2			4-1/2	1-1/4	3	5/8	1-1/8	3/8	.50
WFC-11-2B	1	4/0 MCM	-----	4-1/2	1-1/4	2	5/8	13/16	5/16	.35
WFC-11-4A	2			4-1/2	1-1/4	3	5/8	1-1/8	3/8	.50
WFC-13-2B	1	250 MCM	4/0 MCM	4-1/4	1-1/4	2	5/8	13/16	5/16	.50
WFC-13-4A	2			4-1/2	1-1/4	3	5/8	1-1/8	3/8	.50
WFC-15-2B	1	-----	266.8 MCM	4-1/2	1-1/4	2	5/8	1	3/8	.40
WFC-15-4A	2			4-1/2	1-1/4	3	5/8	1-1/8	3/8	.50
WFC-16-2B	1	336.4 - 350 MCM	266.8 - 300 MCM	4-1/2	1-1/4	2	5/8	1	3/8	.40
WFC-16-4A	2			4-1/2	1-1/4	3	5/8	1-1/8	3/8	.50
WFC-18-2B	1	397.5 MCM	336.4 MCM	4-1/2	1-1/4	2	5/8	1	3/8	.40
WFC-18-4A	2			4-1/2	1-1/4	3	5/8	1-1/8	3/8	.50
WFC-20-2B	1	450 - 500 MCM	397.5 MCM	4-3/4	1-1/2	2	5/8	1-1/8	3/8	.50
WFC-20-4A	2			4-3/4	1-1/2	3	5/8	1-1/8	3/8	.75
WFC-21-2B	1	550 - 556.5 MCM	477 MCM	4-3/4	1-1/2	2	5/8	1-5/16	1/2	.50
WFC-21-4A	2			4-3/4	1-1/2	3	5/8	13/16	7/16	.85
WFC-22-2B	1	-----	477 MCM	4-3/4	1-1/2	2	5/8	1-1/4	7/16	.85
WFC-22-4A	2			4-3/4	1-1/2	3	5/8	1-3/16	7/16	.85
WFC-24-2B	1	636 - 750 MCM	556.5 MCM	5-1/4	1-7/8	2	5/8	1-1/4	1/2	.75
WFC-24-4A	2			5-1/4	1-7/8	3	5/8	1-1/4	1/2	1.00

ALUMINUM TERMINALS

TYPE WFC Continued

CATALOG NUMBER	FIG. NO.	CONDUCTOR RANGE		DIMENSIONS - INCHES						WEIGHT (POUNDS)
		AAC	ACSR	A	B	C	D	E	T	
WFC-29-2B	1	750 - 795 MCM	636 - 666 MCM	5-1/8	1-7/8	2	5/8	1-3/8	1/2	.75
WFC-29-4A	2			5-1/4	1-7/8	3	5/8	1-3/8	1/2	1.00
WFC-34-2B	2	954 - 1033 MCM	795 - 954 MCM	5	1-3/4	2	5/8	1-9/16	5/8	1.00
WFC-34-4A	2			5	1-3/4	3	5/8	1-9/16	5/8	1.00
WFC-34-4B	2			6-3/8	2	4	1-1/8	1-1/2	1/2	1.66
WFC-35-2B	1	954 - 1113 MCM	954 MCM	5	1-3/4	2	5/8	1-9/16	5/8	1.00
WFC-35-4A	2			5	1-3/4	3	5/8	1-9/16	5/8	1.00
WFC-35-4B	2			6-1/4	2	4	1-1/8	1-3/8	1/2	1.25
WFC-36-2B	1	1000 - 1033.5 MCM	954 MCM	5	1-3/4	2	5/8	1-9/16	5/8	1.00
WFC-36-4A	2			5	1-3/4	3	5/8	1-9/16	5/8	1.00
WFC-36-4B	2			6-1/4	2	4	1-1/8	1-3/8	1/2	1.25
WFC-37-2B	1	1113 - 1272 MCM	1027 - 1192 MCM	5-1/8	1-7/8	2	5/8	1-3/8	1/2	1.00
WFC-37-4A	2			5-1/8	1-7/8	3	5/8	1-3/8	1/2	1.00
WFC-37-4B	2			6-1/4	1-7/8	4	1-1/8	1-7/16	9/16	1.50
WFC-39-2B	1	1272 MCM	-----	5-1/8	1-7/8	2	5/8	1-3/8	1/2	1.00
WFC-39-4A	2			5-1/8	1-7/8	3	5/8	1-3/8	1/2	1.00
WFC-39-4B	2			6-5/8	2-1/4	4	1-1/8	1-9/16	5/8	1.75
WFC-41-2B	1	1351 - 1430 MCM	1192 - 1272 MCM	5-3/4	2-3/8	2	5/8	1-7/16	9/16	1.50
WFC-41-4A	2			5-3/4	2-3/8	3	5/8	1-7/16	9/16	1.50
WFC-41-4B	2			6-7/8	2-3/8	4	1-1/8	2-1/8	3/4	1.75
WFC-43-2B	1	1500 - 1600 MCM	1351 - 1431 MCM	5-7/8	2-1/2	2	5/8	1-5/8	5/8	1.50
WFC-43-4A	2			5-7/8	2-1/2	3	5/8	1-5/8	5/8	1.50
WFC-43-4B	2			6-7/8	2-1/2	4	1-1/8	1-5/8	5/8	2.00
WFC-46-4A	2	1750 MCM	1590 MCM	5-7/8	2-1/2	3	5/8	1-5/8	5/8	1.50
WFC-46-4B	2			7-5/16	2-5/8	4	1-1/8	2-1/16	3/4	2.75
WFC-49-4A	2	2000 MCM	1780 - 2034 MCM	6-5/16	2-3/4	3	5/8	2-1/16	3/4	2.50
WFC-49-4B	2			7-5/16	2-3/4	4	1-1/8	2-1/16	3/4	2.50
WFC-51-4A	2	2250 - 2336 MCM	2156 MCM	5-3/4	2-3/8	3	5/8	2	3/4	2.50
WFC-51-4B	2			6-3/4	2-3/8	4	1-1/8	2	3/4	2.50
WFC-52-4A	2	2500 MCM	-----	6-1/4	2-3/4	3	5/8	2-1/8	3/4	2.50
WFC-52-4B	2			6-3/4	2-3/4	4	1-1/8	2-1/8	3/4	2.50
WFC-54-4A	2	3000 MCM	-----	6-3/4	2-3/4	3	5/8	2-1/4	7/8	4.00
WFC-54-4B	2			7-1/4	2-3/4	4	1-1/8	2-1/4	7/8	4.00
WFC-56-4A	2	3500 MCM	-----	7	3	3	5/8	2-1/4	1-1/8	5.25
WFC-56-4B	2			7-1/2	3	4	1-1/8	2-1/4	1-1/8	5.50

ALUMINUM TERMINALS

TYPE WFC2

Straight Welded

Two Cables to Flat Pad

Aluminum alloy weldment terminal for connecting two aluminum cables to flat pad. Flat pads have NEMA drilling.

Contact sealant is recommended for contact pad after welding.

Angle connectors may be obtained by specifying the desired angle.

Example: WFC2-90-34-4B

Casting Alloy: 356-T6 Aluminum
Options: See Page 89

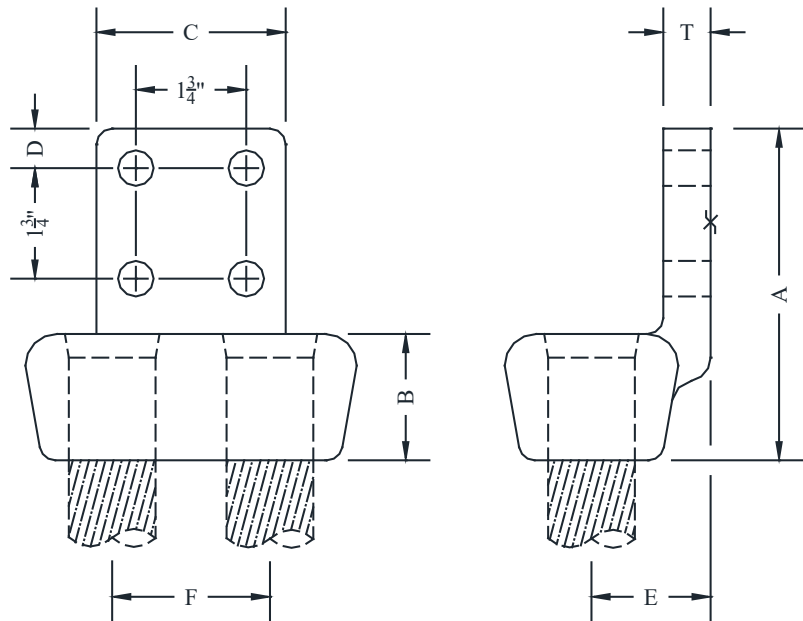

CATALOG NUMBER	CONDUCTOR RANGE		DIMENSIONS - INCHES							WEIGHT (POUNDS)
	AAC	ACSR	A	B	C	D	E	F	T	
WFC2-13-4A	250 MCM	#4/0 STR	4-3/8	1-3/8	3	5/8	1	1-3/8	3/8	1.00
WFC2-13-4B			5-3/8	1-3/8	4	1-1/8	1	1-3/8	3/8	1.25
WFC2-16-4A	336.4 - 350 MCM	266.8 - 300 MCM	4-3/8	1-3/8	3	5/8	1	1-3/8	3/8	1.00
WFC2-16-4B			5-3/8	1-3/8	4	1-1/8	1	1-3/8	3/8	1.25
WFC2-18-4A	397.5 MCM	336.4 MCM	4-3/8	1-3/8	3	5/8	1	1-3/8	3/8	1.25
WFC2-18-4B			5-3/8	1-3/8	4	1-1/8	1	1-3/8	3/8	1.25
WFC2-20-4A	477 - 500 MCM	397.5 MCM	4-3/4	1-1/2	3	5/8	1-1/8	1-1/4	3/8	1.00
WFC2-20-4B			5-3/4	1-1/2	4	1-1/8	1-1/8	1-1/4	3/8	1.25
WFC2-21-4A	550 - 556.5 MCM	-----	4-3/4	1-1/2	3	5/8	1-1/8	1-1/4	3/8	1.00
WFC2-21-4B			5-3/4	1-1/2	4	1-1/8	1-1/8	1-1/4	3/8	1.25
WFC2-22-4A	556 MCM	477 MCM	4-3/4	1-1/2	3	5/8	1-1/8	1-1/4	3/8	1.00
WFC2-22-4B			5-3/4	1-1/2	4	1-1/8	1-1/8	1-1/4	3/8	1.25
WFC2-24-4A	636 - 750 MCM	556.5 MCM	4-7/8	1-1/2	3	5/8	1-1/8	1-1/2	1/2	1.00
WFC2-24-4B			5-7/8	1-1/2	4	1-1/8	1-3/8	1-1/2	1/2	1.30
WFC2-29-4A	750 - 795 MCM	636 - 666 MCM	5-3/8	1-7/8	3	5/8	1-3/8	1-3/4	1/2	2.00
WFC2-29-4B			6-3/16	1-13/16	4	1-1/8	1-11/16	2	3/4	3.00

ALUMINUM TERMINALS

TYPE WFC2 Continued

CATALOG NUMBER	CONDUCTOR RANGE		DIMENSIONS - INCHES							WEIGHT (POUNDS)
	AAC	ACSR	A	B	C	D	E	F	T	
WFC2-34-4A	954 - 1033 MCM	795 MCM	6	2-3/4	3	5/8	1-3/4	2	7/8	2.50
WFC2-34-4B			7-1/8	2-3/4	4	1-1/8	1-3/4	2	7/8	3.00
WFC2-35-4A	1033.5 MCM	954 MCM	6	2-3/4	3	5/8	1-3/4	2	7/8	2.50
WFC2-35-4B			7-1/8	2-3/4	4	1-1/8	1-3/4	2	7/8	3.00
WFC2-36-4A	1100 - 1033.5 MCM	954 MCM	5-1/4	2	3	5/8	1-5/8	2	11/16	3.00
WFC2-36-4B			6-1/2	2-1/2	4	1-1/8	1-7/8	2-1/2	3/4	3.50
WFC2-37-4A	1113 - 1192 MCM	1033.5 MCM	5	1-3/4	3	5/8	1-9/16	2	3/4	3.00
WFC2-37-4B			6-1/8	1-3/4	4	1-1/8	1-9/16	2	3/4	3.00
WFC2-39-4A	1250 - 1300 MCM	1113 - 1192 MCM	5-1/4	2	3	5/8	1-7/8	2-1/2	3/4	2.50
WFC2-39-4B			6-3/8	2	4	1-1/8	1-11/16	1-3/4	5/8	2.50
WFC2-41-4A	1351 - 1431 MCM	1192 - 1272 MCM	6-3/8	2-1/2	3	5/8	1-3/4	2-1/2	3/4	2.50
WFC2-41-4B			6-7/8	2-1/2	4	1-1/8	1-3/4	2-1/2	3/4	2.50
WFC2-43-4A	1500 - 1600 MCM	1351(54/19), 1431 MCM	6	2-1/2	3	5/8	1-3/4	2	3/4	2.25
WFC2-43-4B			6-7/8	2-1/2	4	1-1/8	1-3/4	2	3/4	2.75
WFC2-46-4A	1700 - 1750 MCM	1510.5 - 1590 MCM	6-1/8	2-3/4	3	5/8	2-1/4	3	1	6.00
WFC2-46-4B			7-1/8	2-3/4	4	1-1/8	2-1/4	3	1	6.00
WFC2-49-4A	2000 MCM	1780 - 2034 MCM	6-3/4	2-3/4	3	5/8	2-1/4	3	1-1/8	5.70
WFC2-49-4B			7-1/4	2-3/4	4	1-1/8	2-3/8	3	1-1/8	5.70
WFC2-50-4A	2300 MCM	2167, 2156 MCM	6-1/8	2-3/4	3	5/8	2-1/4	3	1	4.75
WFC2-50-4B			7-1/8	2-3/4	4	1-1/8	2-1/4	3	1	5.00
WFC2-52-4A	2500 MCM	2312 MCM	6-1/4	2-3/4	3	5/8	2-1/8	3	3/4	4.00
WFC2-52-4B			6-3/4	2-3/4	4	1-1/8	2-1/8	3	3/4	4.25

ALUMINUM TERMINALS

TYPE WFC3

Straight Welded

Three Cables to Flat Pad

Casting Alloy: 356-T6 Aluminum
Options: See Page 89

Aluminum alloy weldment terminal for connecting three aluminum cables to flat pad.

Flat pads have NEMA drilling.

Contact sealant is recommended for contact pad after welding.

Angle connectors may be obtained by specifying the desired angle.

Example: WFC3-90-34-4B

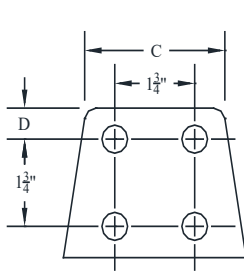

FIG. 1

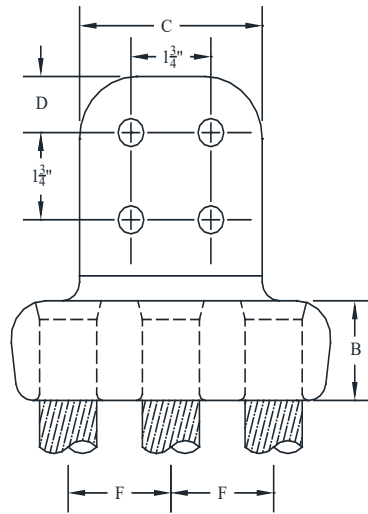

FIG. 2

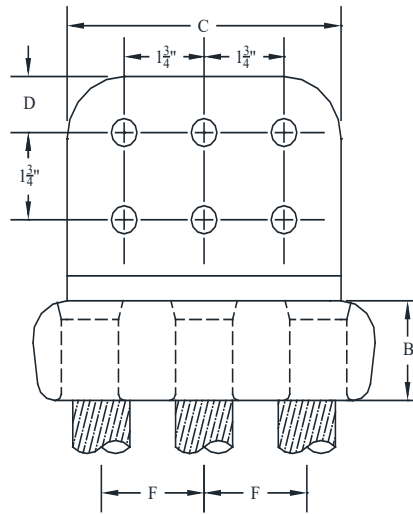
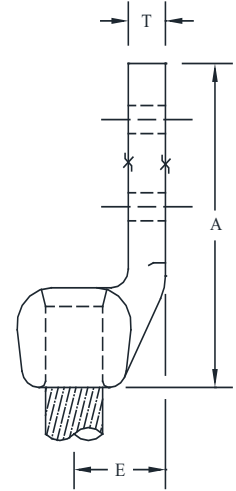

FIG. 3



CATALOG NUMBER	FIG. NO.	CONDUCTOR RANGE		DIMENSIONS - INCHES							WEIGHT (POUNDS)
		AAC	ACSR	A	B	C	D	E	F	T	
WFC3-34-4A	1	954 - 1033 MCM	795 - 945(45/7) MCM	5-1/2	2	3	5/8	2	2-1/4	13/16	3.82
WFC3-34-4B	2			6-1/2	2	4	1-1/8	2	2-1/4	13/16	3.82
WFC3-36-4B	2	1000 - 1113 MCM	900 - 1033 MCM	6-1/2	2	4	1-1/8	2	2-1/2	7/8	4.30
WFC3-36-6B	3			6-1/2	2	6	1-1/8	2	2-1/2	7/8	4.75
WFC3-39-4A	1	1250 - 1300 MCM	1113 - 1192 MCM	5-7/8	2-3/8	3	5/8	2-1/8	2-1/8	1	5.00
WFC3-39-4B	2			6-7/8	2-3/8	4	1-1/8	2-1/8	2-1/8	1	5.00
WFC3-39-6B	3			6-7/8	2-3/8	6	1-1/8	2-1/8	2-1/8	7/8	3.75
WFC3-41-4B	2	1250 - 1510 MCM	1192 - 1272 MCM	6-7/8	2-3/8	4	1-1/8	2-1/8	2-1/8	1	5.00
WFC3-41-6B	3			6-7/8	2-3/8	6	1-1/8	2-1/8	2-1/8	7/8	5.00
WFC3-43-4A	1	1590 MCM	1272 MCM	6-1/8	2-1/2	3	5/8	2	2	1	4.60
WFC3-43-4B	2			7-1/8	2-1/2	4	1-1/8	2	2	1	4.60
WFC3-43-6B	3			7	2-5/8	6	1-1/8	2	2	3/4	5.50
WFC3-46-4A	1	1750 MCM	1590 MCM	6-7/8	2-3/4	3	5/8	2-7/16	2-1/4	1-1/4	7.00
WFC3-46-4B	2			7-1/8	2-3/4	4	1-1/8	2-7/16	2-1/4	1-1/4	7.00
WFC3-46-6B	3			7-1/8	2-3/4	6	1-1/8	2-1/16	2-1/4	1	7.00

ALUMINUM TERMINALS

TYPE WFT

Weldment
Pipe to Flat Pad

Aluminum alloy weldment terminal for connecting aluminum pipe to flat pad.
Side-formed tongues have NEMA drilling.
Contact sealant is recommended for contact pad after welding.
Angle connectors may be obtained by specifying desired angle.
Example: WFT90-53-2B

Casting Alloy: 356-T6 Aluminum
Options: See Page 89

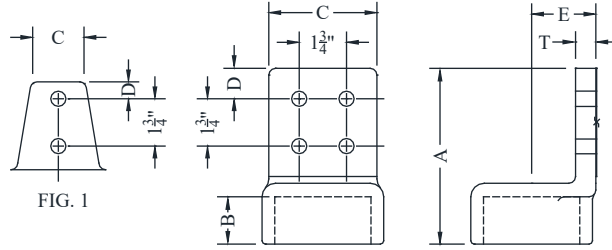

FIG. 2

CATALOG NUMBER	FIG. NO.	PIPE SIZE (NPS)	DIMENSIONS - INCHES						WEIGHT (POUNDS)
			A	B	C	D	E	T	
WFT-30-2B	1	3/4	4-5/8	7/8	2	5/8	1-1/8	3/8	.50
WFT-30-4A	2		4-5/8	7/8	3	5/8	1-1/8	3/8	.60
WFT-30-4B	2		4-5/8	7/8	4	1-1/8	1-1/8	3/8	.75
WFT-39-2B	1	1	4-7/16	7/8	2	5/8	1-3/16	3/8	.50
WFT-39-4A	2		4-3/8	7/8	3	5/8	1-1/4	3/8	1.00
WFT-39-4B	2		5-7/8	7/8	4	1-1/8	1-1/4	3/8	1.65
WFT-49-2B	1	1-1/4	4-5/8	1	2	5/8	1-3/8	3/8	.75
WFT-49-4A	2		4-3/4	1	3	5/8	1-3/8	3/8	.75
WFT-49-4B	2		5-3/4	1	4	1-1/8	1-3/8	3/8	1.25
WFT-53-2B	1	1-1/2	4-13/16	1-3/8	2	5/8	1-1/2	7/16	1.00
WFT-53-4A	2		4-15/16	1-3/8	3	5/8	1-1/2	13/32	1.00
WFT-53-4B	2		6-7/16	1-3/8	4	1-1/8	1-1/2	3/8	1.65
WFT-58-2B	1	2	5-1/8	1-1/2	2	5/8	1-3/4	1/2	1.50
WFT-58-4A	2		5-1/8	1-1/2	3	5/8	1-3/4	1/2	1.50
WFT-58-4B	2		6-1/4	1-1/2	4	1-1/8	1-3/4	1/2	1.65
WFT-60-2B	1	2-1/2	5-1/8	1-1/2	2	5/8	2	5/8	2.00
WFT-60-4A	2		5-1/8	1-1/2	3	5/8	2	5/8	1.75
WFT-60-4B	2		5-7/8	1-1/2	4	1-1/8	2	1/2	2.25
WFT-62-2B	1	3	5-1/2	1-3/4	2	5/8	2-3/8	3/4	3.25
WFT-62-4A	2		5-1/2	1-3/4	3	5/8	2-3/8	3/4	3.25
WFT-62-4B	2		6-1/2	1-3/4	4	1-1/8	2-3/8	3/4	3.25
WFT-63-2B	1	3-1/2	5-5/8	1-7/8	2	5/8	2-5/8	3/4	3.00
WFT-63-4A	2		5-5/8	1-7/8	3	5/8	2-5/8	3/4	3.00
WFT-63-4B	2		6-3/8	1-7/8	4	1-1/8	2-5/8	3/4	3.50
WFT-64-2B	1	4	6	2	2	5/8	2-7/8	3/4	3.25
WFT-64-4A	2		6	2	3	5/8	2-7/8	3/4	3.25
WFT-64-4B	2		6-7/8	2	4	1-1/8	2-7/8	3/4	4.75
WFT-67-4A	2	5	7	2-7/8	3	5/8	3-1/2	1	7.50
WFT-67-4B	2		8	2-7/8	4	1-1/8	3-1/2	1	7.50
WFT-69-4B	2	6	8-1/4	3	4	1-1/8	4-1/4	1-1/4	10.00

ALUMINUM TERMINALS

TYPE WFTC

Weldment
Pipe to Flat Pad

Casting Alloy: 356-T6 Aluminum
Options: See Page 89

Aluminum alloy weldment terminal for connecting aluminum pipe to flat pad.
Center-formed tongues have NEMA drilling.
Contact sealant is recommended for contact pad after welding.

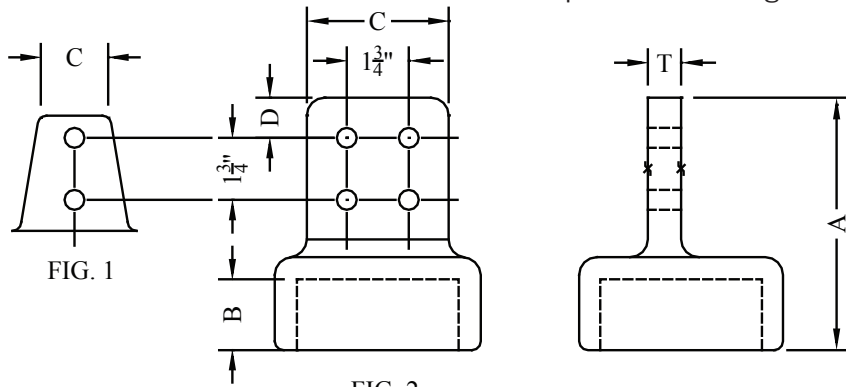

CATALOG NUMBER	FIG. NO.	PIPE SIZE (NPS)	DIMENSIONS - INCHES					WEIGHT (POUNDS)
			A	B	C	D	T	
WFTC-30-2B	1	3/4	4-5/8	15/16	2	5/8	3/8	0.40
WFTC-30-4A	2		4-5/8	15/16	3	5/8	3/8	0.50
WFTC-30-4B	2		5-5/8	15/16	4	1-1/8	3/8	0.60
WFTC-39-2B	1	1	4-5/8	15/16	2	5/8	3/8	0.40
WFTC-39-4A	2		4-5/8	15/16	3	5/8	3/8	0.50
WFTC-39-4B	2		5-5/8	15/16	4	1-1/8	3/8	0.60
WFTC-49-2B	1	1-1/4	4-3/4	1	2	5/8	3/8	0.80
WFTC-49-4A	2		4-3/4	1	3	5/8	3/8	0.90
WFTC-49-4B	2		5-3/4	1	4	1-1/8	3/8	1.00
WFTC-53-2B	1	1-1/2	5-1/8	1-3/8	2	5/8	1/2	1.00
WFTC-53-4A	2		5-1/8	1-3/8	3	5/8	1/2	1.00
WFTC-53-4B	2		6-1/8	1-3/8	4	1-1/8	1/2	1.25
WFTC-58-2B	1	2	5-1/4	1-1/2	2	5/8	1/2	1.25
WFTC-58-4A	2		5-1/4	1-1/2	3	5/8	1/2	1.50
WFTC-58-4B	2		6-1/4	1-1/2	4	1-1/8	7/16	1.75
WFTC-60-2B	1	2-1/2	5-5/16	1-1/2	2	5/8	1/2	1.50
WFTC-60-4A	2		5-5/16	1-1/2	3	5/8	1/2	1.70
WFTC-60-4B	2		6-1/4	1-1/2	4	1-1/8	1/2	2.10
WFTC-62-2B	1	3	5-3/4	1-3/4	2	5/8	5/8	2.40
WFTC-62-4A	2		5-3/4	1-3/4	3	5/8	5/8	2.60
WFTC-62-4B	2		6-3/4	1-3/4	4	1-1/8	5/8	2.90
WFTC-63-2B	1	3-1/2	5-3/4	1-7/8	2	5/8	3/4	2.75
WFTC-63-4A	2		5-3/4	1-7/8	3	5/8	3/4	3.00
WFTC-63-4B	2		6-7/8	1-7/8	4	1-1/8	3/4	3.50
WFTC-64-2B	1	4	5-7/8	2	2	5/8	3/4	3.00
WFTC-64-4A	2		5-7/8	2	3	5/8	3/4	3.30
WFTC-64-4B	2		7-1/8	2	4	1-1/8	15/16	3.80
WFTC-67-4A	2	5	7	2-7/8	3	5/8	1	6.20
WFTC-67-4B	2		8	2-7/8	4	1-1/8	1	6.60
WFTC-69-4B	2	6	8	2-3/4	4	1-1/8	1-1/8	8.50

ALUMINUM TERMINALS

TYPE WFTI

Internal Weldment
Pipe to Flat Pad

Casting Alloy: 356-T6 Aluminum
Options: See Page 89

Aluminum alloy weldment terminal for connecting standard (SCH 40) aluminum pipe to flat pad. Flat pads have NEMA drilling.

Contact sealant is recommended for contact pad after welding.

Angle connectors may be obtained by specifying desired angle.

Example: WFTI90-53-4A

For SCH 80 pipe, add suffix (H) to catalog number.

Example: WFTI-60H-2B

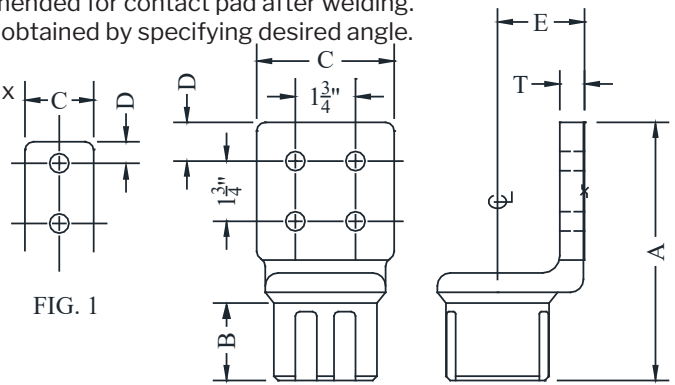

FIG. 1

FIG. 2

CATALOG NUMBER	FIG. NO.	PIPE SIZE (NPS)	DIMENSIONS - INCHES						WEIGHT (POUNDS)
			A	B	C	D	E	T	
WFTI-30-2B	1	3/4	4-3/4	1	2	5/8	3/4	3/8	.40
WFTI-30-4A	2		4-3/4	1	3	5/8	3/4	3/8	.40
WFTI-30-4B	2		5-3/4	1	4	1-1/8	3/4	3/8	.65
WFTI-39-2B	1	1	4-7/8	1-1/8	2	5/8	1	3/8	.50
WFTI-39-4A	2		4-7/8	1-1/8	3	5/8	1	3/8	.50
WFTI-39-4B	2		5-7/8	1-1/8	4	1-1/8	1	3/8	.75
WFTI-49-2B	1	1-1/4	5	1-1/4	2	5/8	1-1/4	3/8	.65
WFTI-49-4A	2		5	1-1/4	3	5/8	1-1/4	3/8	.65
WFTI-49-4B	2		6	1-1/4	4	1-1/8	1-1/4	3/8	.90
WFTI-53-2B	1	1-1/2	5-1/8	1-3/8	2	5/8	1-1/2	1/2	1.25
WFTI-53-4A	2		5-1/8	1-3/8	3	5/8	1-1/2	1/2	1.25
WFTI-53-4B	2		6-1/8	1-3/8	4	1-1/8	1-1/2	1/2	1.25
WFTI-58-2B	1	2	5-3/4	1-3/4	2	5/8	1-3/4	1/2	1.50
WFTI-58-4A	2		5-3/4	1-3/4	3	5/8	1-3/4	1/2	1.50
WFTI-58-4B	2		6-3/4	1-3/4	4	1-1/8	1-3/4	1/2	1.50
WFTI-60-2B	1	2-1/2	6-1/4	2-1/4	2	5/8	2	1/2	1.65
WFTI-60-4A	2		6-1/4	2-1/4	3	5/8	2	1/2	1.65
WFTI-60-4B	2		6-7/8	2-1/8	4	1-1/8	2	5/8	2.50
WFTI-62-2B	1	3	6-1/2	2-1/4	2	5/8	2-1/2	11/16	3.00
WFTI-62-4A	2		6-1/2	2-1/4	3	5/8	2-1/2	11/16	3.00
WFTI-62-4B	2		7-1/2	2-1/4	4	1-1/8	2-1/2	11/16	3.00
WFTI-63-2B	1	3-1/2	6-7/8	2-3/4	2	5/8	2-5/8	5/8	3.50
WFTI-63-4A	2		6-7/8	2-3/4	3	5/8	2-5/8	5/8	3.50
WFTI-63-4B	2		7-7/8	2-3/4	4	1-1/8	2-5/8	5/8	3.50
WFTI-64-2B	1	4	6-1/8	2-1/4	2	5/8	2-7/8	3/4	3.55
WFTI-64-4A	2		6-1/8	2-1/4	3	5/8	2-7/8	3/4	3.55
WFTI-64-4B	2		7-1/8	2-1/2	4	1-1/8	2-7/8	3/4	3.55
WFTI-67-4A	2	5	7-1/8	2-3/8	3	5/8	3-1/2	7/8	6.75
WFTI-67-4B	2		8	2-3/4	4	1-1/8	3-1/2	7/8	6.75
WFTI-69-4B	2	6	9-3/8	3	4	1-1/8	3-7/8	1-1/8	12.00

ALUMINUM TERMINALS

TYPE WFTIC

Internal Weldment
Pipe to Flat Pad

Aluminum alloy weldment terminal for connecting standard (SCH 40) aluminum pipe to flat pad. Center-formed tongues have NEMA drilling.
Contact sealant is recommended for contact pad after welding.
For SCH 80 pipe, add suffix (H) to catalog number.
Example: WFTIC-58H-2B

Casting Alloy: 356-T6 Aluminum
Options: See Page 89

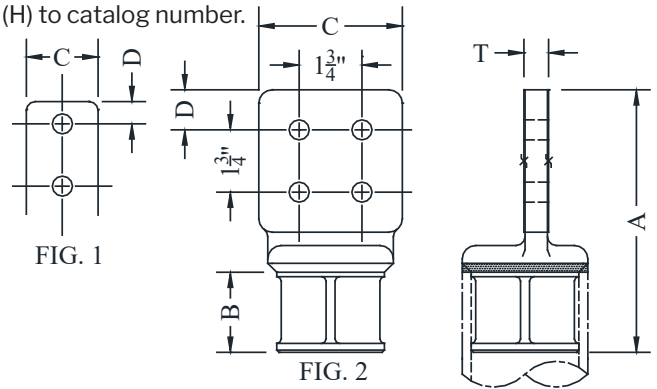

CATALOG NUMBER	FIG. NO.	PIPE SIZE (NPS)	DIMENSIONS - INCHES					WEIGHT (POUNDS)
			A	B	C	D	T	
WFTIC-30-2B	1	3/4	4-1/2	3/4	2	5/8	3/8	.30
WFTIC-30-4A	2		4-1/2	3/4	3	5/8	3/8	.30
WFTIC-30-4B	2		5-1/2	3/4	4	1-1/8	3/8	.50
WFTIC-39-2B	1	1	4-5/8	3/4	2	5/8	3/8	.40
WFTIC-39-4A	2		4-5/8	3/4	3	5/8	3/8	.40
WFTIC-39-4B	2		5-5/8	3/4	4	1-1/8	3/8	.60
WFTIC-49-2B	1	1-1/4	4-3/4	7/8	2	5/8	3/8	.25
WFTIC-49-4A	2		4-3/4	7/8	3	5/8	3/8	.75
WFTIC-49-4B	2		5-3/4	7/8	4	1-1/8	3/8	.75
WFTIC-53-2B	1	1-1/2	5-1/4	1-1/4	2	5/8	1/2	1.00
WFTIC-53-4A	2		5-3/8	1-1/4	3	5/8	1/2	1.50
WFTIC-53-4B	2		6-3/8	1-1/4	4	1-1/8	1/2	1.85
WFTIC-58-2B	1	2	5-1/4	1-1/4	2	5/8	1/2	1.00
WFTIC-58-4A	2		5-1/4	1-1/4	3	5/8	1/2	1.00
WFTIC-58-4B	2		6-1/4	1-1/4	4	1-1/8	3/8	2.00
WFTIC-60-2B	1	2-1/2	6-1/8	2-1/8	2	5/8	1/2	1.50
WFTIC-60-4A	2		6-1/8	2-1/8	3	5/8	1/2	1.50
WFTIC-60-4B	2		7-1/8	2-1/8	4	1-1/8	1/2	1.75
WFTIC-62-2B	1	3	6-3/8	2-1/4	2	5/8	11/16	2.00
WFTIC-62-4A	2		6-3/8	2-1/4	3	5/8	11/16	2.00
WFTIC-62-4B	2		7-3/8	2-1/4	4	1-1/8	5/8	2.50
WFTIC-63-2B	1	3-1/2	7	2-3/4	2	5/8	5/8	3.50
WFTIC-63-4A	2		7	2-3/4	3	5/8	5/8	3.50
WFTIC-63-4B	2		8	2-3/4	4	1-1/8	5/8	3.50
WFTIC-64-2B	1	4	6-7/8	2-1/2	2	5/8	1	4.00
WFTIC-64-4A	2		6-7/8	2-1/2	3	5/8	3/4	3.25
WFTIC-64-4B	2		7-7/8	2-1/2	4	1-1/8	1	4.40
WFTIC-67-4A	2	5	7-3/8	2-3/4	3	5/8	1	5.25
WFTIC-67-4B	2		8-3/8	2-3/4	4	1-1/8	1	5.25
WFTIC-69-4B	2	6	8-7/8	3	4	1-1/8	1-1/4	7.00

ALUMINUM TERMINALS

TYPE WFTIR

Angle Weldment
Pipe to Flat Pad

Casting Alloy: 356-T6 Aluminum
Options: See Page 89

Aluminum welded variable angle terminal. Note that the angles are limited by the conductor size.
Consult manufacturer for further details or unlisted applications.

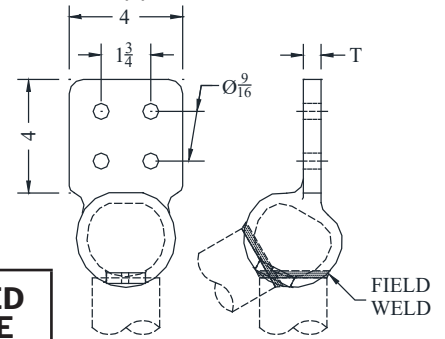

CATALOG NUMBER	PIPE SIZE	NPS	LIMITED ANGLE	NPS	LIMITED ANGLE
WFTIR-6062-4B	2-1/2" - 3" NPS	2-1/2"	0 - 55°	3"	0 - 60°
WFTIR-6467-4B	4" - 5" NPS	4"	0 - 40°	5"	0 - 60°

TYPE WFTIW-63-4B

Weldment
4x4 IWCB to Flat

Casting Alloy: 356-T6 Aluminum
Options: See Page 89

Aluminum alloy weldment terminal for connecting 4x4 IWCB to aluminum flat pad. Center-formed tongues has NEMA drilling.
Contact sealant is recommended for contact pad after welding.

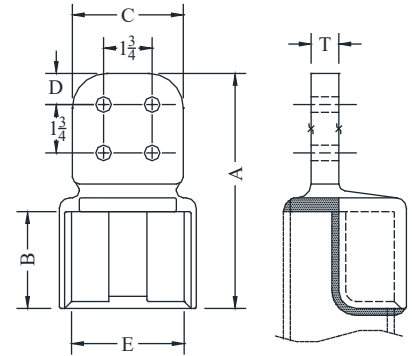

CATALOG NUMBER	CONDUCTOR SIZE	DIMENSIONS - INCHES						WEIGHT (POUNDS)
		A	B	C	D	E	T	
WFTIW-63-4B	4x4 IWCB	8-1/2	3-1/2	4	1-1/8	4	1	4.25

TYPE WFXIW-63-4B

Weldment
4x4 IWCB to Flat

Casting Alloy: 356-T6 Aluminum
Laminated Straps: 1100-0 Aluminum
Options: See Page 89

Aluminum weldment expansion terminal for connecting 4x4 IWCB to flat pad. Center-formed tongues has NEMA drilling.
Contact sealant is recommended for contact pad after welding.

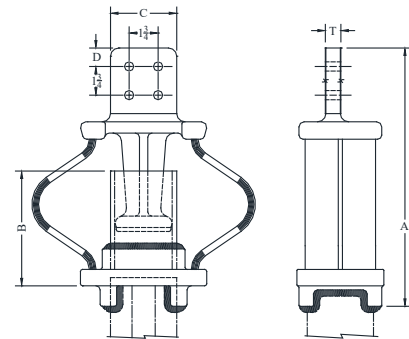

CATALOG NUMBER	CONDUCTOR SIZE	DIMENSIONS - INCHES					WEIGHT (POUNDS)
		A	B	C	D	T	
WFXIW-63-4B	4x4 IWCB	16-1/4	7-1/4	4	1-1/8	7/8	16.55

ALUMINUM TERMINALS

TYPE WFTO

Weldment
Pipe to Flat Pad

Aluminum alloy weldment terminal for connecting aluminum pipe to flat pad.
Side-formed tongues have NEMA drilling.
Contact sealant is recommended for contact pad after welding.
Angle connectors may be obtained by specifying desired angle.
Example: WFTO90-58-4A

Casting Alloy: 356-T6 Aluminum
Options: See Page 89

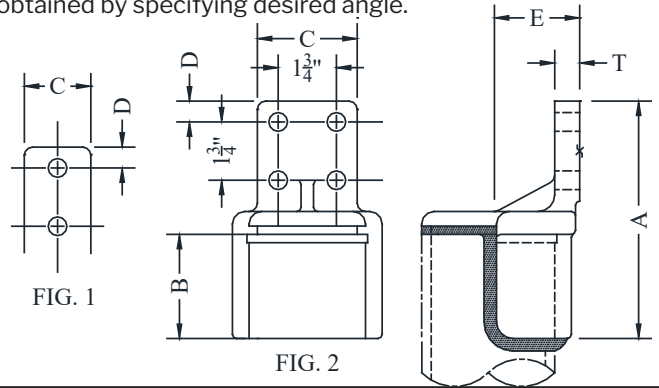

CATALOG NUMBER	FIG. NO.	PIPE SIZE (NPS)	DIMENSIONS - INCHES						WEIGHT (POUNDS)
			A	B	C	D	E	T	
WFTO-30-2B	1	3/4	5-3/4	2-1/4	2	5/8	1	3/8	1.00
WFTO-30-4A	2		5-5/8	2-1/4	3	5/8	1	5/16	.50
WFTO-30-4B	2		6-5/8	2-1/4	4	1-1/8	1	5/16	1.25
WFTO-39-2B	1	1	5-3/4	2-1/4	2	5/8	1-1/4	3/8	1.00
WFTO-39-4A	2		5-7/8	2-3/8	3	5/8	1-1/4	3/8	.75
WFTO-39-4B	2		6-3/4	2-1/4	4	1-1/8	1-1/4	3/8	1.25
WFTO-49-2B	1	1-1/4	6-3/8	2-1/2	2	5/8	1-3/8	7/16	1.00
WFTO-49-4A	2		6-3/8	2-1/2	3	5/8	1-3/8	7/16	1.00
WFTO-49-4B	2		7-3/8	2-1/2	4	1-1/8	1-3/8	3/8	1.25
WFTO-53-2B	1	1-1/2	6-5/8	2-3/4	2	5/8	1-1/2	7/16	.75
WFTO-53-4A	2		6-7/8	3	3	5/8	1-5/8	7/16	1.25
WFTO-53-4B	2		7-3/16	3	4	1-1/8	1-5/8	7/16	1.25
WFTO-58-2B	1	2	7-3/8	3-1/4	2	5/8	1-3/4	1/2	1.50
WFTO-58-4A	2		7-3/8	3-1/4	3	5/8	1-3/4	1/2	1.75
WFTO-58-4B	2		7-15/16	3-1/4	4	1-1/8	1-3/4	1/2	2.00
WFTO-60-2B	1	2-1/2	7-3/8	3-1/2	2	5/8	2	9/16	1.75
WFTO-60-4A	2		7-5/8	3-1/2	3	5/8	2	9/16	2.00
WFTO-60-4B	2		8-3/4	3-1/2	4	1-1/8	2	1/2	2.50
WFTO-62-2B	1	3	7-1/8	3-1/8	2	5/8	2-1/2	3/4	2.50
WFTO-62-4A	2		7-1/8	3-1/8	3	5/8	2-1/2	3/4	2.50
WFTO-62-4B	2		8-1/8	3-1/8	4	1-1/8	2-3/8	5/8	3.00
WFTO-63-2B	1	3-1/2	7-5/8	3-1/2	2	5/8	2-5/8	5/8	3.50
WFTO-63-4A	2		7-5/8	3-1/2	3	5/8	2-5/8	5/8	3.50
WFTO-63-4B	2		8-5/8	3-1/2	4	1-1/8	2-5/8	5/8	3.50
WFTO-64-2B	1	4	7-1/2	3-1/4	2	5/8	2-7/8	3/4	4.00
WFTO-64-4A	2		7-1/2	3-1/4	3	5/8	2-7/8	3/4	3.50
WFTO-64-4B	2		8-1/2	3-1/4	4	1-1/8	2-7/8	3/4	4.00
WFTO-67-4A	2	5	7	3	3	5/8	3-3/8	3/4	7.25
WFTO-67-4B	2		8-1/2	3	4	1-1/8	3-1/2	3/4	4.75
WFTO-69-4B	2	6	9-3/16	4-1/4	4	1-1/8	4	1	6.75

ALUMINUM TERMINALS

TYPE WFTOC

Weldment
Pipe to Flat Pad

Aluminum alloy weldment terminal for connecting aluminum pipe to flat pad. Center-formed tongues have NEMA drilling. Contact sealant is recommended for contact pad after welding.

Casting Alloy: 356-T6 Aluminum
Options: See Page 89

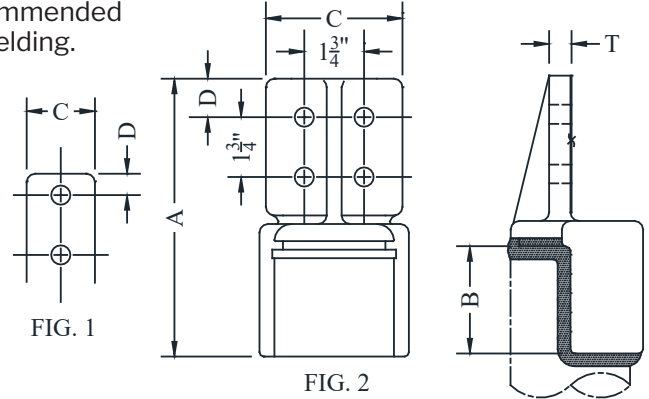

CATALOG NUMBER	FIG. NO.	PIPE SIZE (NPS)	DIMENSIONS - INCHES					WEIGHT (POUNDS)
			A	B	C	D	T	
WFTOC-30-2B	1	3/4	6-1/8	2-1/2	2	5/8	3/8	0.50
WFTOC-30-4A	2		6-1/4	2-1/2	3	5/8	3/8	0.60
WFTOC-30-4B	2		7-1/4	2-1/2	4	1-1/8	3/8	0.85
WFTOC-39-2B	1	1	6-1/8	2-1/2	2	5/8	3/8	0.50
WFTOC-39-4A	2		6-1/4	2-1/2	3	5/8	3/8	0.75
WFTOC-39-4B	2		7-1/4	2-1/2	4	1-1/8	3/8	0.85
WFTOC-49-2B	1	1-1/4	6-5/8	2-3/4	2	5/8	3/8	0.70
WFTOC-49-4A	2		6-3/4	2-3/4	3	5/8	3/8	0.90
WFTOC-49-4B	2		7-3/4	2-3/4	4	1-1/8	3/8	1.15
WFTOC-53-2B	1	1-1/2	6-9/16	2-3/4	2	5/8	7/16	1.00
WFTOC-53-4A	2		6-9/16	2-3/4	3	5/8	7/16	1.00
WFTOC-53-4B	2		7-3/4	2-3/4	4	1-1/8	1/2	1.91
WFTOC-58-2B	1	2	7-3/8	3-1/4	1-3/4	5/8	1/2	1.25
WFTOC-58-4A	2		7-3/8	3-1/4	3	5/8	1/2	1.50
WFTOC-58-4B	2		8-1/4	3-1/4	4	1-1/8	1/2	1.75
WFTOC-60-2B	1	2-1/2	7-3/8	3-1/2	2	5/8	1/2	1.50
WFTOC-60-4A	2		7-1/2	3-1/2	3	5/8	1/2	1.75
WFTOC-60-4B	2		8-1/2	3-1/2	4	1-1/8	1/2	2.25
WFTOC-62-2B	1	3	7-1/8	3-1/8	2	5/8	5/8	2.50
WFTOC-62-4A	2		7-1/8	3-1/8	3	5/8	5/8	2.50
WFTOC-62-4B	2		8-3/16	3-1/8	4	1-1/8	5/8	2.65
WFTOC-63-2B	1	3-1/2	7-3/4	3-1/2	2	5/8	11/16	3.25
WFTOC-63-4A	2		7-3/4	3-1/2	3	5/8	11/16	3.25
WFTOC-63-4B	2		8-3/4	3-1/2	4	1-1/8	11/16	3.75
WFTOC-64-2B	1	4	7-1/2	3-1/4	2	5/8	3/4	4.00
WFTOC-64-4A	2		7-1/2	3-1/4	3	5/8	3/4	3.50
WFTOC-64-4B	2		8-1/2	3-1/4	4	1-1/8	3/4	4.00
WFTOC-67-4A	2	5	7-1/4	3	3	5/8	3/4	5.00
WFTOC-67-4B	2		8-3/8	3	4	1-1/8	3/4	5.00
WFTOC-69-4B	2	6	9-1/8	4	4	1-1/8	7/8	6.75

ALUMINUM TERMINALS

TYPE WFXT

Weldment Expansion
Pipe to Flat Pad

Aluminum weldment expansion terminal for aluminum pipe to flat pad. Side-formed tongues. Guides are sized for use with standard SCH 40 pipe. Flat pads have NEMA drilling. Contact sealant is recommended. Add suffix (H) to catalog number for SCH 80 pipe. Example: WFXT-60H-4A

Casting Alloy: 356-T6 Aluminum
Laminated Straps: 1100-0 Aluminum
Options: See Page 89

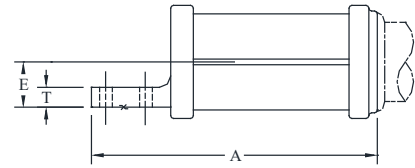
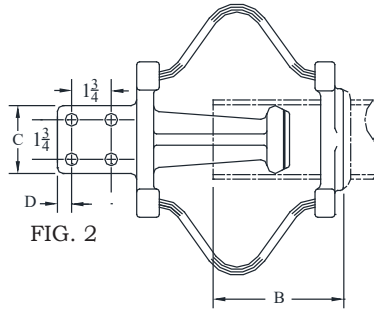
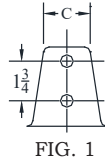

CATALOG NUMBER	FIG. NO.	PIPE SIZE (NPS)	DIMENSIONS - INCHES						WEIGHT (POUNDS)
			A	B	C	D	E	T	
WFXT-30-2B	1	3/4	10-3/4	4-3/4	2	5/8	1	3/8	2.00
WFXT-30-4A	2		10-3/4	4-3/4	3	5/8	1	3/8	2.75
WFXT-30-4B	2		10-3/4	4-3/4	4	1-1/8	1	3/8	2.75
WFXT-39-2B	1	1	11-5/8	6	2	5/8	1-1/4	1/2	2.75
WFXT-39-4A	2		11-3/8	6	3	5/8	1-1/4	1/2	3.15
WFXT-39-4B	2		12-3/8	6	4	1-1/8	1-1/4	1/2	3.55
WFXT-49-2B	1	1-1/4	11-1/8	5-1/4	2	5/8	1-3/4	3/8	3.25
WFXT-49-4A	2		11-1/8	5-1/4	3	5/8	1-3/4	3/8	3.25
WFXT-49-4B	2		12-1/8	5-1/4	4	1-1/8	1-3/4	3/8	3.25
WFXT-53-2B	1	1-1/2	11-5/8	5-3/8	2	5/8	1-9/16	5/8	3.55
WFXT-53-4A	2		11-5/8	5-3/8	3	5/8	1-9/16	5/8	3.55
WFXT-53-4B	2		12-5/8	5-3/8	4	1-1/8	1-1/2	5/8	4.00
WFXT-58-2B	1	2	11-7/8	5-5/8	2	5/8	1-3/4	1/2	4.75
WFXT-58-4A	2		12	5-1/2	3	5/8	1-3/4	1/2	5.00
WFXT-58-4B	2		13-1/4	5-3/4	4	1-1/8	1-3/4	1/2	5.00
WFXT-60-2B	1	2-1/2	12-1/2	5-3/4	2	5/8	2	11/16	8.45
WFXT-60-4A	2		12-3/4	6	3	5/8	2	11/16	8.45
WFXT-60-4B	2		13-3/4	6	4	1-1/8	2	3/4	9.20
WFXT-62-2B	1	3	12-5/8	5-3/4	2	5/8	2	7/8	9.90
WFXT-62-4A	2		12-5/8	5-3/4	3	5/8	2	7/8	9.90
WFXT-62-4B	2		13-3/32	5-3/4	4	1-1/8	2-1/2	7/8	10.90
WFXT-63-2B	1	3-1/2	11-1/2	5	2	5/8	2-5/8	7/8	13.40
WFXT-63-4A	2		12-9/16	6-1/16	3	5/8	2-5/8	7/8	13.40
WFXT-63-4B	2		13-7/16	6	4	1-1/8	2-5/8	11/16	15.50
WFXT-64-2B	1	4	12-5/8	5-1/2	2	5/8	2-7/8	7/8	14.80
WFXT-64-4A	2		12-5/8	5-1/2	3	5/8	2-7/8	7/8	14.80
WFXT-64-4B	2		13-5/8	5-3/4	4	1-1/8	2-7/8	1	15.55
WFXT-67-4A	2	5	14-3/8	6-3/4	3	5/8	3-1/2	1	24.20
WFXT-67-4B	2		15-3/8	6-3/4	4	1-1/8	3-1/2	1	24.20
WFXT-69-4B	2	6	16-1/2	7-3/8	4	1-1/8	3-7/8	1	26.55

ALUMINUM TERMINALS

TYPE WFXTC

Weldment Expansion
Pipe to Flat Pad

Aluminum weldment expansion terminal for aluminum pipe to flat pad. Center-formed tongues. Guides are sized for use with standard SCH 40 pipe. Flat pads have NEMA drilling. Contact sealant is recommended. Add suffix (H) to catalog number for SCH 80 pipe. Example: WFXTC-58H-4B

Casting Alloy: 356-T6 Aluminum
Laminated Straps: 1100-0 Aluminum
Options: See Page 89

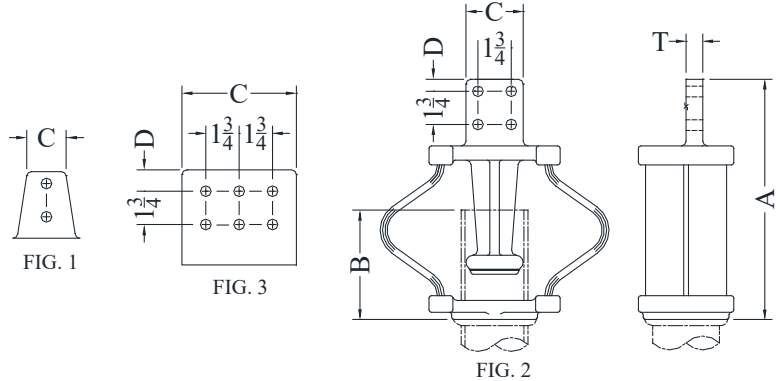

CATALOG NUMBER	FIG. NO.	PIPE SIZE (NPS)	DIMENSIONS - INCHES					WEIGHT (POUNDS)
			A	B	C	D	T	
WFXTC-39-2B	1	1	11-3/8	6	2	5/8	1/2	2.65
WFXTC-39-4A	2		11-1/2	6	3	5/8	1/2	3.20
WFXTC-39-4B	2		13	6	4	1-1/8	1/2	3.65
WFXTC-49-2B	1	1-1/4	11-3/4	5-1/2	2	5/8	3/4	4.35
WFXTC-49-4A	2		11-1/2	5-1/4	3	5/8	1/2	4.20
WFXTC-53-2B	1	1-1/2	11-5/8	5-1/2	2	5/8	9/16	3.80
WFXTC-53-4A	2		11-5/8	5-1/2	3	5/8	9/16	3.80
WFXTC-53-4B	2		12-3/4	5-1/2	4	1-1/8	5/8	4.10
WFXTC-58-2B	1	2	11-3/4	5-1/2	2	5/8	11/16	5.50
WFXTC-58-4A	2		11-3/4	5-1/2	3	5/8	11/16	5.50
WFXTC-58-4B	2		13	5-1/2	4	1-1/8	1/2	5.75
WFXTC-60-2B	1	2-1/2	12-1/2	5-1/2	2	5/8	5/8	8.45
WFXTC-60-4A	2		12-1/2	5-1/2	3	5/8	11/16	8.45
WFXTC-60-4B	2		13-1/2	5-1/2	4	1-1/8	5/8	8.45
WFXTC-62-2B	1	3	11-3/8	4-1/2	2	5/8	11/16	9.65
WFXTC-62-4A	2		12-7/8	6	3	5/8	7/8	10.15
WFXTC-62-4B	2		13-7/8	6	4	1-1/8	7/8	10.90
WFXTC-63-2B	1	3-1/2	12-7/8	6	2	5/8	3/4	12.40
WFXTC-63-4A	2		12-7/8	6	3	5/8	3/4	12.40
WFXTC-63-4B	2		13-7/8	6	4	1-1/8	7/8	12.40
WFXTC-64-2B	1	4	13-1/8	6	2	5/8	3/4	14.85
WFXTC-64-4A	2		12-3/4	6	3	5/8	3/4	14.85
WFXTC-64-4B	2		13-3/4	6	4	1-1/8	1	15.60
WFXTC-64-6B	3		14	6	6	1-1/8	1	18.40
WFXTC-67-4A	2	5	13-3/4	6-3/4	3	5/8	1-1/4	22.20
WFXTC-67-4B	2		15-7/8	7-3/8	4	1-1/8	1-1/4	22.20
WFXTC-67-6B	3		15-7/8	7-3/8	6	1-1/8	1	22.70
WFXTC-69-4B	2	6	15-3/4	7-3/8	4	1-1/8	1-1/4	24.55
WFXTC-69-6B	3		16-1/4	7-3/8	6	1-1/8	1	28.80

ALUMINUM TERMINALS

TYPE WFXTC-V

Weldment Expansion
Pipe to Flat Pad

Aluminum weldment expansion terminal for aluminum pipe to flat pad. Center-formed tongues. Guides are sized for use with standard SCH 40 pipe. Flat pads have NEMA drilling. Contact sealant is recommended. Add suffix (H) to catalog number for SCH 80 pipe. Example: WFXTC-V-60H-4A

Casting Alloy: 356-T6 Aluminum
Laminated Straps: 1100-0 Aluminum
Options: See Page 89

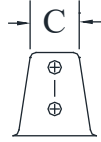

FIG. 1

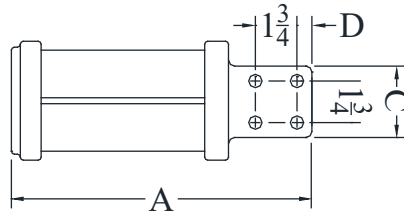
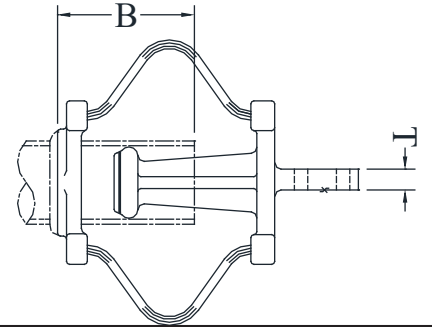

FIG. 2



CATALOG NUMBER	FIG. NO.	PIPE SIZE (NPS)	DIMENSIONS - INCHES					WEIGHT (POUNDS)
			A	B	C	D	T	
WFXTC-V-30-2B	1	3/4	11	5	2	5/8	1/2	2.75
WFXTC-V-30-4A	2		11	5	3	5/8	1/2	2.75
WFXTC-V-30-4B	2		12	5	4	1-1/8	1/2	3.00
WFXTC-V-39-2B	1	1	11-3/8	6	2	5/8	1/2	3.00
WFXTC-V-39-4A	2		11-3/8	5-3/4	3	5/8	1/2	3.00
WFXTC-V-39-4B	2		12-1/4	5-1/2	4	1-1/8	3/8	3.25
WFXTC-V-49-2B	1	1-1/4	11-1/8	5-1/4	2	5/8	5/8	3.70
WFXTC-V-49-4A	2		11-1/8	5-1/4	3	5/8	5/8	3.70
WFXTC-V-49-4B	2		12-1/4	5-1/2	4	1-1/8	5/8	4.00
WFXTC-V-53-2B	1	1-1/2	11-5/8	5-1/2	2	5/8	5/8	4.25
WFXTC-V-53-4A	2		11-5/8	5-1/2	3	5/8	5/8	4.25
WFXTC-V-53-4B	2		12-5/8	5-5/8	4	1-1/8	5/8	4.50
WFXTC-V-58-2B	1	2	12	5-1/2	2	5/8	9/16	5.25
WFXTC-V-58-4A	2		12	5-1/2	3	5/8	9/16	5.25
WFXTC-V-58-4B	2		13	5-1/2	4	1-1/8	1/2	5.50
WFXTC-V-60-2B	1	2-1/2	12-1/2	5-1/2	2	5/8	5/8	8.65
WFXTC-V-60-4A	2		12-1/2	5-1/2	3	5/8	5/8	8.65
WFXTC-V-60-4B	2		13-1/2	5-1/2	4	1-1/8	5/8	10.00
WFXTC-V-62-2B	1	3	12-3/4	6	2	5/8	5/8	10.60
WFXTC-V-62-4A	2		12-3/4	6	3	5/8	5/8	10.60
WFXTC-V-62-4B	2		13-5/8	6	4	1-1/8	7/8	11.00
WFXTC-V-63-2B	1	3-1/2	12-7/8	6	2	5/8	3/4	12.50
WFXTC-V-63-4A	2		12-7/8	6	3	5/8	3/4	12.50
WFXTC-V-63-4B	2		13-1/2	6	4	1-1/8	7/8	12.75
WFXTC-V-64-2B	1	4	12-7/8	6	2	5/8	7/8	15.50
WFXTC-V-64-4A	2		12-7/8	6	3	5/8	7/8	15.50
WFXTC-V-64-4B	2		13-3/4	6	4	1-1/8	7/8	16.00
WFXTC-V-67-4A	2	5	13-1/2	6-3/4	3	5/8	1-1/8	22.00
WFXTC-V-67-4B	2		15-7/8	7-3/8	4	1-1/8	1-1/8	23.00
WFXTC-V-69-4B	2	6	15-7/8	7-3/8	4	1-1/8	1-1/4	26.00

ALUMINUM TERMINALS

TYPE WSFFT

Weldment Expansion
Pipe to Flat Pad

Aluminum semi-flexible terminal for connecting aluminum pipe to flat. Aluminum pad surface is coated with contact sealant and factory-bolted to laminated strap. Flat pad on laminated strap has NEMA drilling. Contact sealant is recommended.
NOTE: This connector is not recommended as a support member.

Casting Alloy: 356-T6 Aluminum
Laminated Straps: Copper (Contact Pads Tin Plated)
Strap Mounting Hardware: Stainless Steel
Options: See Page 89

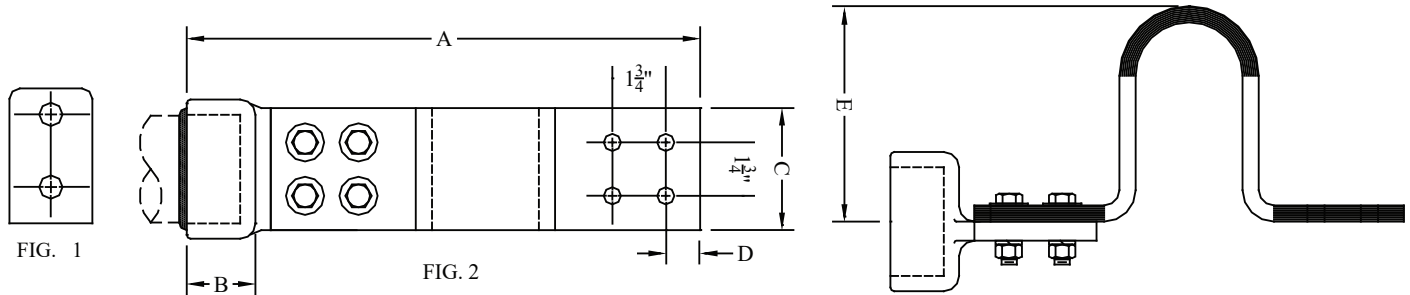

CATALOG NUMBER	FIG. NO.	PIPE SIZE (NPS)	DIMENSIONS - INCHES					WEIGHT (POUNDS)
			A	B	C	D	E	
WSFFT-30-2B	1	3/4	12-5/8	15/16	2	5/8	6	5.60
WSFFT-30-4A	2		12-5/8	15/16	3	5/8	6	5.80
WSFFT-39-2B	1	1	14-3/8	2-1/2	2	5/8	6-1/2	6.20
WSFFT-39-4A	2		12-3/4	15/16	3	5/8	6-1/2	6.75
WSFFT-49-2B	1	1-1/4	13-1/2	1	2	5/8	6-3/8	7.50
WSFFT-49-4A	2		13-7/8	1	3	5/8	6-1/4	8.25
WSFFT-53-2B	1	1-1/2	14-1/4	1-3/8	2	5/8	7-1/4	8.85
WSFFT-53-4A	2		14-1/4	1-3/8	3	5/8	7-1/4	8.85
WSFFT-53-4B	2		15-5/8	1-3/8	4	1-1/8	6-3/4	9.50
WSFFT-58-2B	1	2	14	1-1/2	2	5/8	6-5/8	11.50
WSFFT-58-4A	2		14	1-1/2	3	5/8	6-5/8	11.70
WSFFT-58-4B	2		16	1-1/2	4	1-1/8	5-5/8	12.50
WSFFT-60-2B	1	2-1/2	14-3/4	1-1/2	2	5/8	7-1/4	12.65
WSFFT-60-4A	2		14-3/4	1-1/2	3	5/8	7-1/4	12.75
WSFFT-60-4B	2		16-1/4	1-1/2	4	1-1/8	5-7/8	13.60
WSFFT-62-2B	1	3	14-1/2	1-3/4	2	5/8	7	14.00
WSFFT-62-4A	2		14-1/2	1-3/4	3	5/8	6-3/4	14.00
WSFFT-62-4B	2		16-3/4	1-3/4	4	1-1/8	7-1/16	14.50
WSFFT-63-4A	2	3-1/2	15-1/2	1-7/8	3	5/8	7-1/2	16.40
WSFFT-63-4B	2		12-3/8	1-7/8	4	1-1/8	8-1/2	17.60
WSFFT-64-4A	2	4	15-5/8	2	3	5/8	7-1/2	19.00
WSFFT-64-4B	2		17-3/4	2	4	1-1/8	8-1/2	19.75
WSFFT-67-4B	2	5	18-7/8	2-7/8	4	1-1/8	7-3/16	20.00

ALUMINUM TERMINALS

TYPE WSFFT90

Weldment Expansion
Pipe to Flat Pipe

Aluminum semi-flexible terminal for connecting aluminum pipe to flat. Aluminum pad surface is coated with contact sealant and factory-bolted to laminated strap. Flat pad on laminated strap has NEMA drilling. Contact sealant is recommended.
NOTE: This connector is not recommended as a support member.

Casting Alloy: 356-T6 Aluminum
Laminated Straps: Copper
(Contact Pads Tin Plated)
Strap Mounting Hardware: Stainless Steel
Options: See Page 89

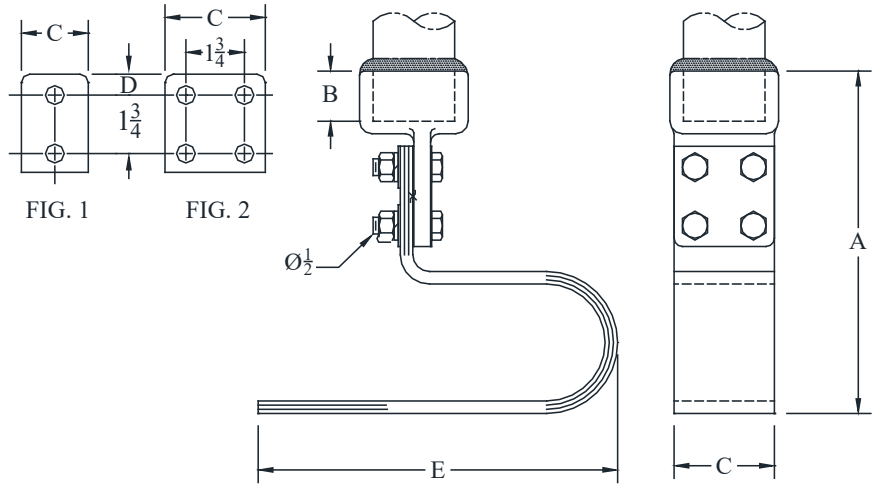

CATALOG NUMBER	FIG. NO.	PIPE SIZE (NPS)	DIMENSIONS - INCHES					WEIGHT (POUNDS)
			A	B	C	D	E	
WSFFT90-30-2B	1	3/4	9	15/16	2	5/8	10	3.85
WSFFT90-30-4A	2		9	15/16	3	5/8	10	4.15
WSFFT90-39-2B	1	1	10-3/4	2-1/2	2	5/8	10-5/8	4.45
WSFFT90-39-4A	2		9	15/16	3	5/8	10-1/4	4.75
WSFFT90-49-2B	1	1-1/4	9-3/4	1	2	5/8	10-1/4	5.75
WSFFT90-49-4A	2		9-3/4	1	3	5/8	10-1/4	6.25
WSFFT90-53-2B	1	1-1/2	10	1-3/8	2	5/8	10-3/8	6.50
WSFFT90-53-4A	2		10-1/8	1-3/8	3	5/8	10-3/4	10.10
WSFFT90-53-4B	2		10-7/8	1-3/8	4	1-1/8	12-7/8	14.85
WSFFT90-58-2B	1	2	10-3/16	1-1/2	2	5/8	11-3/16	8.25
WSFFT90-58-4A	2		10-1/4	1-1/2	3	5/8	10-3/4	10.40
WSFFT90-58-4B	2		11	1-1/2	4	1-1/8	12-7/8	15.10
WSFFT90-60-2B	1	2-1/2	10-1/2	1-1/2	2	5/8	11-7/16	9.15
WSFFT90-60-4A	2		10-1/2	1-1/2	3	5/8	10-7/8	13.95
WSFFT90-60-4B	2		11	1-1/2	4	1-1/8	12-7/8	15.60
WSFFT90-62-2B	1	3	9-5/8	1-3/4	2	5/8	12-7/8	9.75
WSFFT90-62-4A	2		11	1-3/4	3	5/8	10-7/8	15.00
WSFFT90-62-4B	2		12-1/4	1-3/4	4	1-1/8	12-3/4	24.10
WSFFT90-63-4A	2	3-1/2	11-1/2	1-7/8	3	5/8	12-1/2	20.65
WSFFT90-63-4B	2		12-3/8	1-7/8	4	1-1/8	12-3/4	25.00
WSFFT90-64-4A	2	4	11-5/8	2	3	5/8	12-1/2	21.65
WSFFT90-64-4B	2		12-1/4	2	4	1-1/8	12-3/4	24.80
WSFFT90-67-4B	2	5	14-1/8	2-7/8	4	1-1/8	13-1/16	15.75

BRONZE TERMINALS



FNCT

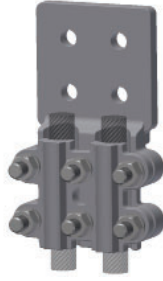

FNCT2

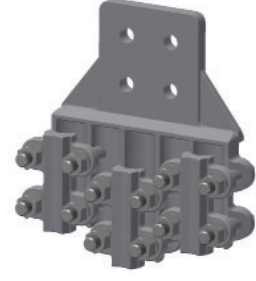

FNCT3



FNCT4



FNCT90



UMX

FNSS

GLT



FNXR



SXR



SXR2



UK



UKG



UKL



UN



UNN



FNTT

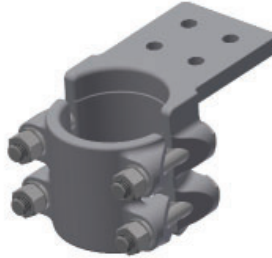

FNTT90

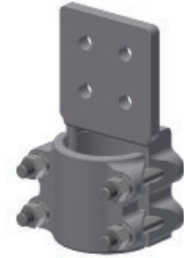

FN TTC



FNXT



SFFT



SFFT90

BRONZE TERMINALS

SEFCOR bronze terminals are cast from certified ingot. Only high quality electrical bronze per ASTM-B145 is utilized to insure current-carrying capability as well as mechanical strength.

This section is arranged in the following sequence for the convenience of the user:

Cable to Flat Pad
Pipe to Flat Pad
Expansion

OPTIONS

A suffix added to a catalog number denotes a variation or option made to the standard cataloged item. The suffixes listed below display the various options available with SEFCOR bronze terminals. Consult manufacturer for further details, unlisted and/or special applications.

- B - Flexible-braid elements in lieu of laminations
- BP - Blank contact pad
- CNS - Supplied with cap nuts
- FF - Finish both sides of contact pad when not customary to do so
- H - For internal fit terminals when SCH 80 pipe is required
- MB - With tongue mounting hardware
- SND - Tin plate entire assembly
- SP - Special requirement, refer to factory
- SS - Stainless steel hardware in lieu of standard hardware
- TP - Tin-planted contact pad
- TTP - Terminal supplied with Bimetallic transition plate
- AG - Silver Plate Entire Assembly

NOTES;

1. Actual dimensions (other than those established by NEMA) of connectors shown may vary slightly. If exact dimensions are required, refer to factory or see assembly drawing.
2. Consult manufacturer for further details or unlisted applications.

BRONZE TERMINALS

TYPE FNCT

Straight Bolted
Cable to Flat Pad

Bronze alloy terminal with hex head clamping bolts for connecting copper cable to flat.

Clamping bolts have hex-stops for one-wrench installation.

Flat pads have NEMA drilling. All sizes are furnished with reversible cable caps.

Casting Alloy: Electrical Bronze
Clamping Hardware: Silicon Bronze
Options: See Page 123

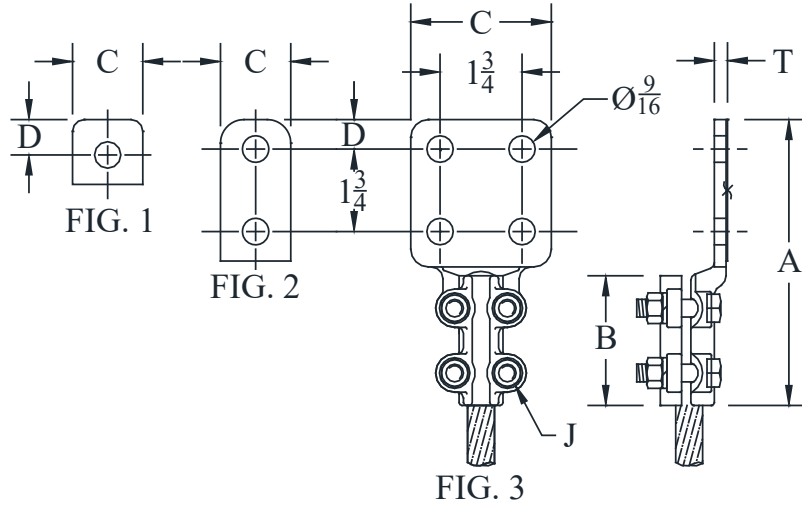

CATALOG NUMBER	FIG NO.	CONDUCTOR RANGE	DIMENSIONS - INCHES						WEIGHT (POUNDS)
			A	B	C	D	J	T	
FNCT-12-1A	1	#6 STR - 250 MCM	4-3/8	2-3/4	1-1/2	3/4	3/8	1/4	1.45
FNCT-12-2A	2		6	2-3/4	1-1/2	5/8	3/8	1/4	1.45
FNCT-12-2B	2		6-1/16	2-3/4	2	5/8	3/8	1/4	1.55
FNCT-12H-2B	2		6-3/8	2-3/4	2	5/8	1/2	1/4	2.45
FNCT-12-4A	3		6-1/16	2-3/4	3	5/8	3/8	1/4	1.95
FNCT-12H-4A	3		6-3/8	2-3/4	3	5/8	1/2	1/4	2.60
FNCT-20-1A	1	1/0 SOL - 500 MCM	5-1/2	3-7/16	1-1/2	3/4	3/8	3/8	2.90
FNCT-20-2B	2		7-1/8	3-7/16	2	5/8	3/8	3/8	2.90
FNCT-20H-2B	2		6-5/16	2-3/4	2	5/8	1/2	5/16	2.90
FNCT-20-4A	3		7-5/16	3-7/16	3	5/8	3/8	7/16	3.15
FNCT-20H-4A	3		6-1/2	2-3/4	3	5/8	1/2	5/16	3.15
FNCT-20-4B	3		8	3-1/2	4	1-1/8	3/8	5/16	3.40
FNCT-20H-4B	3		8-1/4	4-1/16	4	1-1/8	1/2	7/16	4.45
FNCT-34-2B	2	4/0 SOL - 1000 MCM	7-1/16	3-1/2	2	5/8	1/2	1/2	4.15
FNCT-34-4A	3		7-3/16	3-1/2	3	5/8	1/2	7/16	4.30
FNCT-34-4B	3		8-1/16	3-1/2	4	1-1/8	1/2	11/32	5.60
FNCT-42-4A	3	500 - 1500 MCM	7-15/16	4-1/2	3	5/8	1/2	5/8	8.05
FNCT-42-4B	3		8-7/8	4-5/8	4	1-1/8	1/2	9/16	8.55
FNCT-48-2B	2	500 - 2000 MCM	8-3/4	5	2	5/8	1/2	3/4	11.00
FNCT-48-4A	3		9-1/4	5	3	5/8	1/2	3/4	11.60
FNCT-48-4B	3		9-3/4	5	4	1-1/8	1/2	3/4	11.00

BRONZE TERMINALS

TYPE FNCT2

Straight Bolted

Two Cables to Flat Pad

Casting Alloy: Electrical Bronze
Clamping Hardware: Silicon Bronze
Options: See Page 123

Bronze alloy terminal with hex head clamping bolts for connecting two copper cables to flat.

Clamping bolts have hex-stops for one-wrench installation.

Flat pads have NEMA drilling. All sizes furnished with reversible cable caps.

Angle connectors may be obtained by specifying desired angle.

Example: FNCT290-20-2B

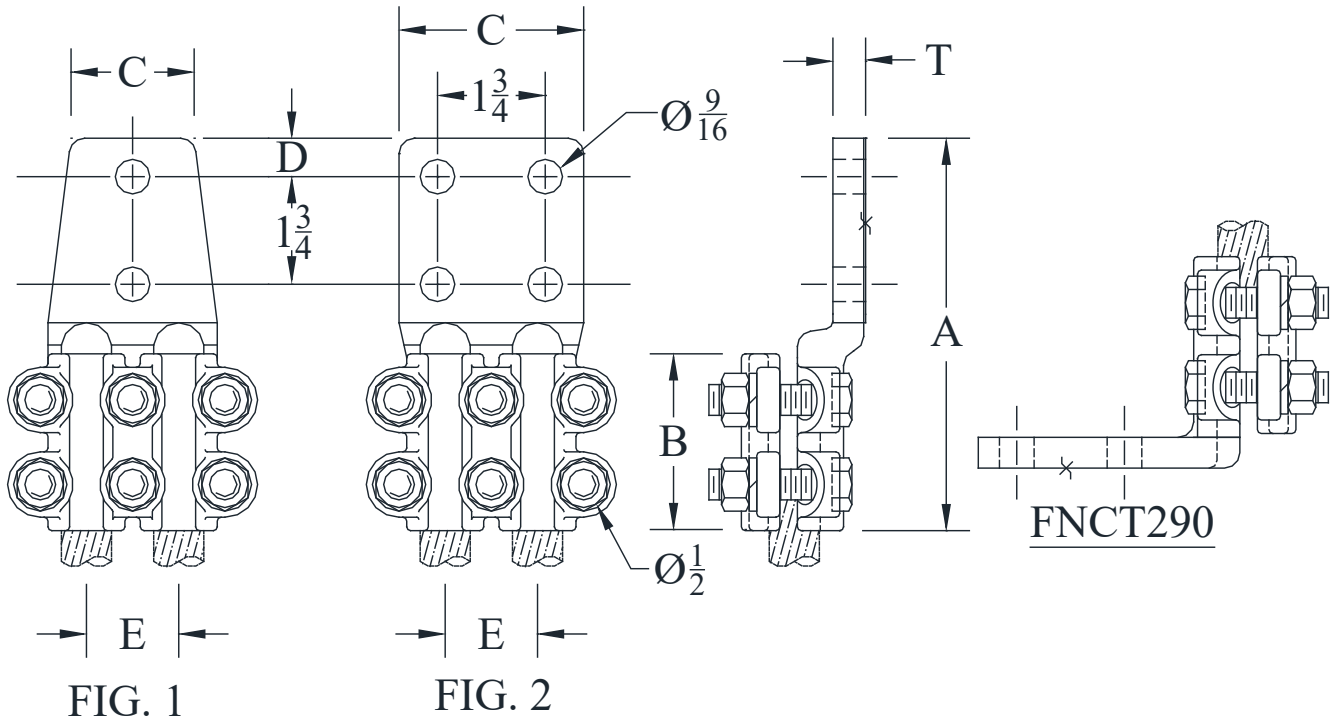

CATALOG NUMBER	FIG. NO.	CONDUCTOR RANGE	DIMENSIONS - INCHES						WEIGHT (POUNDS)
			A	B	C	D	E	T	
FNCT2-12-2B	1	#6 STR - 250 MCM	6-1/4	2-3/4	2	5/8	2-1/8	3/8	3.35
FNCT2-12-4A	2		6	2-3/4	3	5/8	2-1/8	3/8	3.50
FNCT2-20-2B	1	1/0 SOL - 500 MCM	6-3/8	2-7/8	2	5/8	1-1/2	1/2	4.75
FNCT2-20-4A	2		6-3/8	2-7/8	3	5/8	1-1/2	1/2	5.40
FNCT2-20-4B	2		7-1/2	2-7/8	4	1-1/8	1-1/2	1/2	6.15
FNCT2-34-4A	2	4/0 STR - 1000 MCM	7-1/8	3-1/2	3	5/8	1-13/16	1/2	7.25
FNCT2-34-4B	2		7-3/4	3-1/2	4	1-1/8	1-13/16	1/2	7.85
FNCT2-48-4B	2	750 - 2000 MCM	9	4-3/8	4	1-1/8	2-5/8	11/16	17.85

BRONZE TERMINALS

TYPE FNCT3

Straight Bolted

Three Cables to Flat Pad

Bronze alloy terminal with hex head clamping bolts for connecting three copper cables to flat. Clamping bolts have hex-stops for one-wrench installation. Flat pads have NEMA drilling. Angle connectors may be obtained by specifying desired angle. Example: FNCT390-20-4B

Casting Alloy: Electrical Bronze
Clamping Hardware: Silicon Bronze
Options: See Page 123

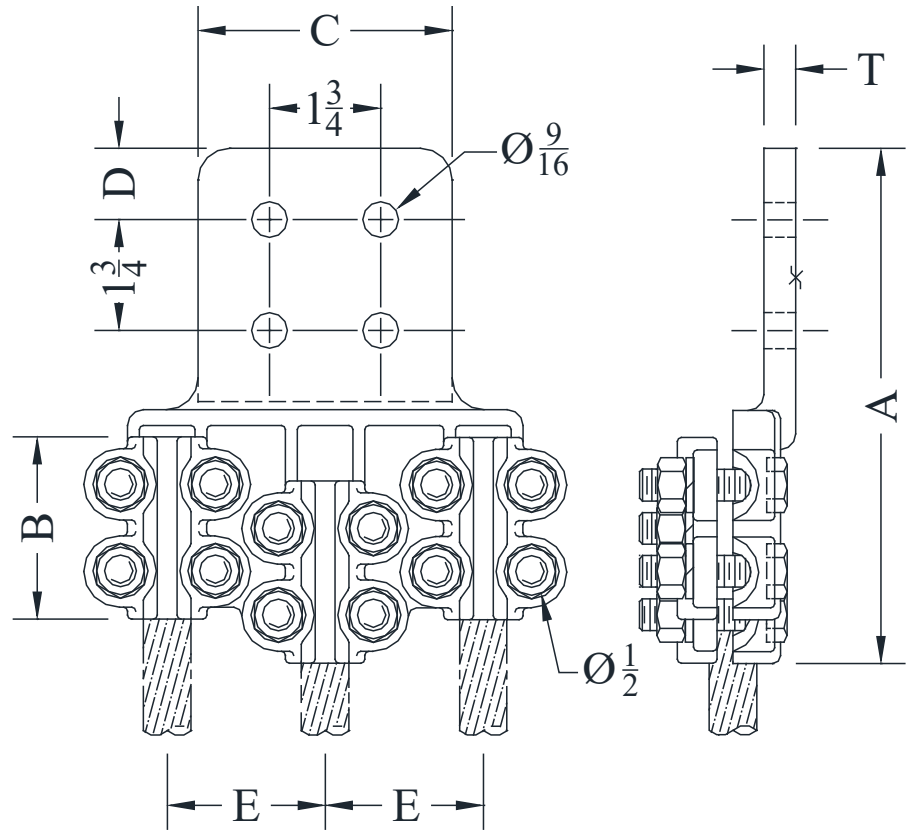

CATALOG NUMBER	CONDUCTOR RANGE	DIMENSIONS - INCHES						WEIGHT (POUNDS)	
		A	B	C	D	E	T		
FNCT3-12-4A	#6 STR - 250 MCM	7-7/8	2-1/2	3	5/8	2-3/8	1/2	7.40	
FNCT3-12-4B		7-7/8	2-1/2	4	1-1/8	2-3/8	1/2	7.40	
FNCT3-20-4A	1/0 SOL - 500 MCM	7-5/8	2-7/8	3	5/8	2-1/2	1/2	10.20	
FNCT3-20-4B		8-1/8	2-7/8	4	1-1/8	2-1/2	1/2	10.20	
FNCT3-34-4A	4/0 STR - 1000 MCM	8	3-1/2	3	5/8	2-3/4	1/2	14.10	
FNCT3-34-4B		9	3-1/2	4	1-1/8	2-3/4	1/2	14.10	
FNCT3-34-6B		8-3/4	3-1/2	6	1-1/8	2-3/4	1/2	14.10	
FNCT3-42-4A	500 - 1500 MCM	8-3/16	4-1/2	3	5/8	3-1/4	7/8	22.40	
FNCT3-42-4B		9-3/16	4-1/2	4	1-1/8	3-1/4	7/8	23.50	
FNCT3-42-6B		9-3/16	4-1/2	6	1-1/8	3-1/4	3/4	25.60	
FNCT3-48-4B	1000 - 2000 MCM	CONTACT FACTORY FOR DETAILS							
FNCT3-48-6B									

BRONZE TERMINALS

TYPE FNCT4

Straight Bolted

Four Cables to Flat Pad

Bronze alloy terminal with hex head clamping bolts for connecting four copper cables to flat. Clamping bolts have hex-stops for one-wrench installation. Flat pads have NEMA drilling. Angle connectors may be obtained by specifying desired angle. Example: FNCT490-20-4B

Casting Alloy: Electrical Bronze
Clamping Hardware: Silicon Bronze
Options: See Page 123

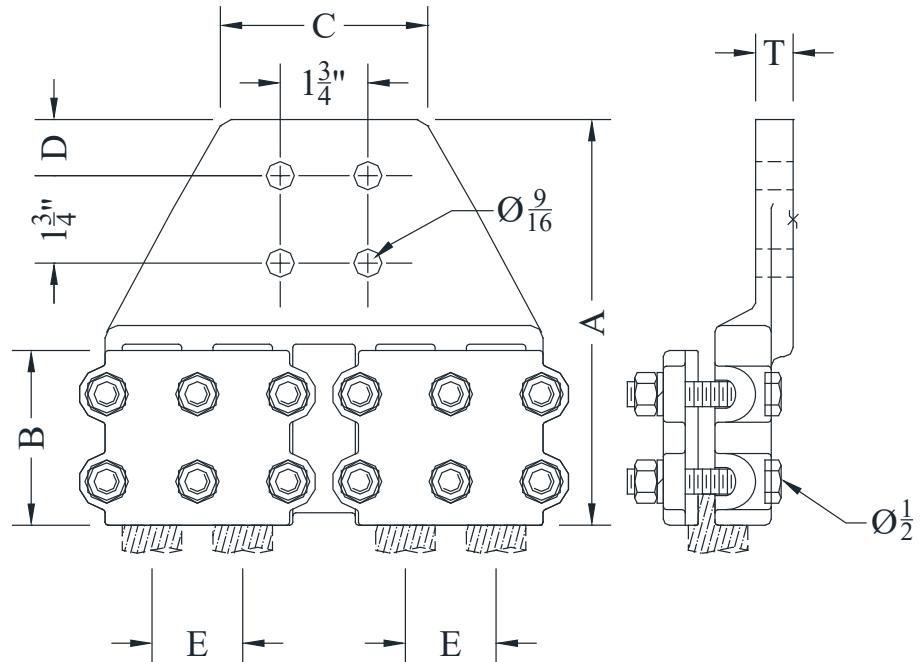

CATALOG NUMBER	CONDUCTOR RANGE	DIMENSIONS - INCHES						WEIGHT (POUNDS)
		A	B	C	D	E	T	
FNCT4-12-4A	#6 STR - 250 MCM	CONTACT FACTORY FOR DETAILS						
FNCT4-12-4B								
FNCT4-20-4A	1/0 SOL - 500 MCM	CONTACT FACTORY FOR DETAILS						
FNCT4-20-4B								
FNCT4-34-4A	500 - 1000 MCM	7-5/8	3-1/2	4	5/8	1-13/16	3/4	22.50
FNCT4-34-4B		8-1/8	3-1/4	4	1-1/8	1-13/16	3/4	22.50
FNCT4-42-4B	1000 - 1500 MCM	CONTACT FACTORY FOR DETAILS						
FNCT4-42-6B								
FNCT4-48-4B	1000 - 2000 MCM	CONTACT FACTORY FOR DETAILS						
FNCT4-48-6B								

BRONZE TERMINALS

TYPE FNCT90

Bolted 90°

Cable to Flat Pad

Bronze alloy terminal with hex-head clamping bolts for connecting copper cable to flat at a 90° angle. Clamping bolts have hex-stops for one-wrench installation. Flat pads have NEMA drilling.

All sizes are furnished with reversible cable caps.

Also available with 45° angle flat pad.

EXAMPLE: FNCT45-34-2B

Casting Alloy: Electrical Bronze
Clamping Hardware: Silicon Bronze
Options: See Page 123

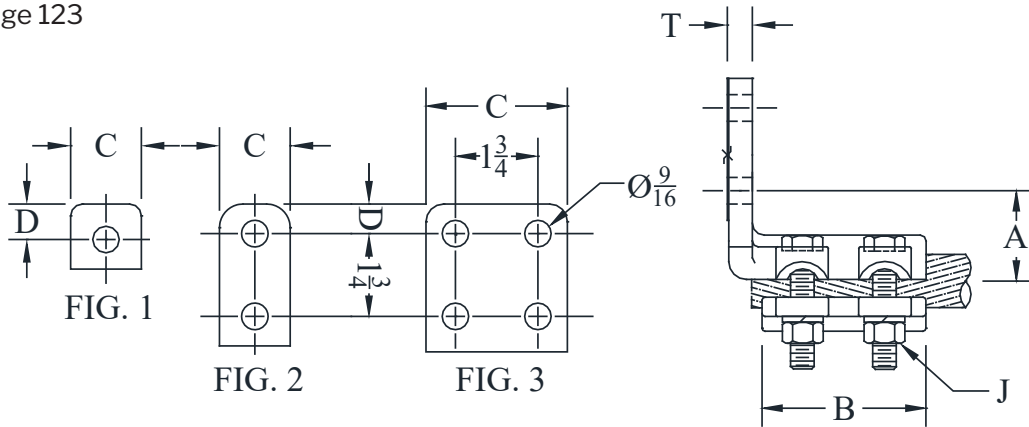

CATALOG NUMBER	FIG. NO.	CONDUCTOR RANGE	DIMENSIONS - INCHES						WEIGHT (POUNDS)
			A	B	C	D	J	T	
FNCT90-12-1A	1	#6 STR - 250 MCM	1-3/8	2-3/4	1-1/2	3/4	3/8	1/4	1.85
FNCT90-12-2A	2		1-3/8	2-3/4	1-1/2	5/8	3/8	1/4	1.85
FNCT90-12-2B	2		1-3/8	2-3/4	2	5/8	3/8	1/4	1.85
FNCT90-12H-2B	2		1-3/8	2-3/4	2	5/8	1/2	5/16	2.05
FNCT90-12-4A	3		1-3/8	2-3/4	3	5/8	3/8	1/4	2.10
FNCT90-12H-4A	3		1-3/8	2-3/4	3	5/8	1/2	5/16	3.10
FNCT90-20-1A	1	1/0 SOL - 500 MCM	1-1/2	3-3/8	1-1/2	1	3/8	3/8	3.20
FNCT90-20-2B	2		1-1/2	3-3/8	2	5/8	3/8	3/8	3.20
FNCT90-20H-2B	2		1-7/16	2-3/4	2	5/8	1/2	5/16	3.15
FNCT90-20-4A	3		1-3/8	3-3/8	3	5/8	3/8	3/8	3.45
FNCT90-20H-4A	3		1-7/16	2-3/4	3	5/8	1/2	5/16	3.15
FNCT90-20-4B	3		1-1/2	3-3/8	4	1-1/8	3/8	3/8	3.45
FNCT90-20H-4B	3		1-7/16	2-3/4	4	1-1/8	1/2	5/16	3.75
FNCT90-34-2B	2	4/0 SOL - 1000 MCM	1-7/8	3-1/2	2	5/8	1/2	1/2	5.35
FNCT90-34-4A	3		1-7/8	3-1/2	3	5/8	1/2	1/2	5.35
FNCT90-34-4B	3		2	4	4	1-1/8	1/2	7/16	5.35
FNCT90-48-2B	2	500 - 2000 MCM	2-7/8	5	2	5/8	1/2	5/8	7.95
FNCT90-48-4A	3		2-7/8	5	3	5/8	1/2	5/8	8.55
FNCT90-48-4B	3		2-7/8	5	4	1-1/8	1/2	3/4	9.50

BRONZE TERMINALS

TYPE FNTT

Straight Bolted
Pipe to Flat Pad

Bronze alloy terminal with hex head clamping bolts for connecting copper pipe to flat. Side formed pad. Clamping bolts have hex-stops for one-wrench installation. Suitable for normal and heavy duty applications. Flat pads have NEMA drilling.

Casting Alloy: Electrical Bronze
Clamping Hardware: Silicon Bronze
Options: See Page 123

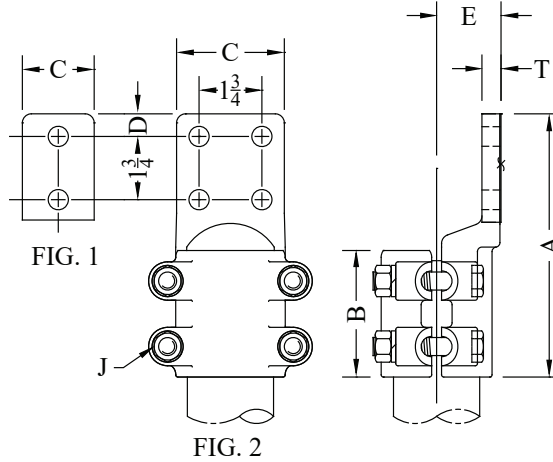

CATALOG NUMBER	FIG. NO.	PIPE SIZE (NPS)	DIMENSIONS - INCHES							WEIGHT (POUNDS)
			A	B	C	D	E	J	T	
FNTT-21-2B	1	1/2	5-1/4	2	2	5/8	1-1/16	3/8	5/16	1.85
FNTT-21-4A	2		5-1/4	2	3	5/8	3/4	3/8	1/4	2.00
FNTT-30-2B	1	3/4	5-3/8	2	2	5/8	7/8	3/8	5/16	2.10
FNTT-30-4A	2		5-3/8	2	3	5/8	7/8	3/8	5/16	2.60
FNTT-39-2B	1	1	5-1/4	2	2	5/8	1-1/4	3/8	3/8	2.70
FNTT-39-4A	2		5-1/4	2	3	5/8	1-1/16	3/8	5/16	2.95
FNTT-39-4B	2		6-7/8	2-1/2	4	1-1/8	1-1/16	3/8	5/16	3.40
FNTT-49-2B	1	1-1/4	6-3/8	2-3/4	2	5/8	1-1/4	1/2	7/16	4.25
FNTT-49-4A	2		6	2-3/4	3	5/8	1-1/4	1/2	3/8	4.50
FNTT-49-4B	2		7-5/8	3	4	1-1/8	1-1/2	1/2	3/8	5.80
FNTT-53-2B	1	1-1/2	6-1/16	2-3/4	2	5/8	1-1/2	1/2	1/2	5.15
FNTT-53-4A	2		6-3/4	3	3	5/8	1-1/2	1/2	3/8	6.95
FNTT-53-4B	2		7-1/4	3	4	1-1/8	1-5/8	1/2	3/8	5.85
FNTT-58-2B	1	2	7-3/8	3-1/2	2	5/8	1-3/4	1/2	1/2	8.35
FNTT-58-4A	2		7-1/4	3-1/2	3	5/8	1-3/4	1/2	1/2	7.05
FNTT-58-4B	2		8-1/4	3-1/2	4	1-1/8	1-7/8	1/2	1/2	8.70
FNTT-60-2B	1	2-1/2	7	3-1/2	2	5/8	2	1/2	9/16	7.85
FNTT-60-4A	2		7	3-1/2	3	5/8	2	1/2	9/16	7.85
FNTT-60-4B	2		7-1/8	3	4	1-1/8	2	1/2	5/8	9.55
FNTT-62-2B	1	3	7-9/16	3-11/16	2	5/8	2-1/2	5/8	5/8	10.00
FNTT-62-4A	2		7-9/16	3-11/16	3	5/8	2-1/2	5/8	5/8	10.00
FNTT-62-4B	2		8-1/16	3-1/4	4	1-1/8	2-1/2	5/8	5/8	14.00
FNTT-63-4A	2	3-1/2	8-8	4-1/2	3	5/8	2-3/4	5/8	3/4	17.50
FNTT-63-4B	2		9-1/8	4-1/2	4	1-1/8	2-3/4	5/8	3/4	17.50
FNTT-64-4A	2	4	6-3/4	3-1/4	3	5/8	3	5/8	1/2	17.90
FNTT-64-4B	2		7-7/16	3-1/4	4	1-1/8	3	5/8	9/16	13.65

BRONZE TERMINALS

TYPE FNNT90

90° Bolted
Pipe to Flat Pad

Bronze alloy terminal for connecting copper pipe to flat at a 90° angle.
Flat pads have NEMA drilling.
Also available 45° angle flat pad. Example: FNNT45-58-4A

Casting Alloy: Electrical Bronze
Clamping Hardware: Silicon Bronze
Options: See Page 123

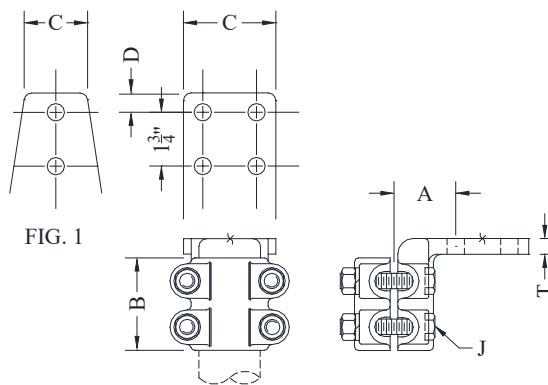

FIG. 2

CATALOG NUMBER	FIG. NO.	PIPE SIZE (NPS)	DIMENSIONS - INCHES						WEIGHT (POUNDS)
			A	B	C	D	J	T	
FNNT90-21-2B	1	1/2	1-3/8	3-1/2	2	5/8	1/2	1/2	2.25
FNNT90-21-4A	2		1-7/8	3-1/2	3	5/8	1/2	1/2	5.35
FNNT90-30-2B	1	3/4	1-1/2	2-7/16	2	5/8	3/8	5/16	2.60
FNNT90-30-4A	2		1-5/8	2-3/8	3	5/8	3/8	3/8	2.85
FNNT90-39-2B	1	1	1-3/4	2-1/2	2	5/8	3/8	7/16	2.80
FNNT90-39-4A	2		1-3/4	2-1/2	3	5/8	3/8	7/16	2.80
FNNT90-39-4B	2		2-1/4	2-1/2	4	1-1/8	3/8	1/4	6.15
FNNT90-49-2B	1	1-1/4	1-13/16	2-7/8	2	5/8	1/2	7/16	3.75
FNNT90-49-4A	2		1-3/4	2-3/4	3	5/8	1/2	3/8	4.80
FNNT90-49-4B	2		2-1/8	2-13/16	4	1-1/8	1/2	3/8	4.50
FNNT90-53-2B	1	1-1/2	2	3	2	5/8	1/2	1/2	6.90
FNNT90-53-4A	2		2	3	3	5/8	1/2	1/2	6.90
FNNT90-53-4B	2		2-1/4	2-13/16	4	1-1/8	1/2	3/8	6.60
FNNT90-58-2B	1	2	2-7/16	3	2	5/8	1/2	1/2	6.65
FNNT90-58-4A	2		2-7/16	3	3	5/8	1/2	1/2	6.65
FNNT90-58-4B	2		3	3	4	1-1/8	1/2	1/2	7.15
FNNT90-60-2B	1	2-1/2	2-3/8	3	2	5/8	1/2	1/2	7.85
FNNT90-60-4A	2		2-3/8	3	3	5/8	1/2	1/2	9.55
FNNT90-60-4B	2		2-7/8	3-1/2	4	1-1/8	1/2	11/16	12.45
FNNT90-62-2B	1	3	3-1/8	4	2	5/8	5/8	5/8	17.25
FNNT90-62-4A	2		3-1/8	4	3	5/8	5/8	5/8	17.25
FNNT90-62-4B	2		3-1/8	4	4	1-1/8	5/8	5/8	17.25
FNNT90-63-4A	2	3-1/2	3-3/4	4-3/8	3	5/8	5/8	3/4	13.00
FNNT90-63-4B	2		3-7/8	4-3/8	4	1-1/8	5/8	3/4	14.00
FNNT90-64-4A	2	4	3-5/8	3-1/4	3	5/8	5/8	9/16	16.20
FNNT90-64-4B	2		4-3/16	4-1/2	4	1-1/8	5/8	3/4	21.65
FNNT90-67-4B	2	5	4-5/8	5	4	1-1/8	5/8	1	20.60

BRONZE TERMINALS

TYPE FNTTC

Straight Bolted
Pipe to Flat Pad

Bronze alloy terminal with hex head clamping bolts for connecting copper pipe to flat. Clamping bolts have hex-stops for one wrench installation. Center-formed pad. Suitable for normal and heavy duty applications. Flat pads have NEMA drilling.

Casting Alloy: Electrical Bronze
Clamping Hardware: Silicon Bronze
Options: See Page 123

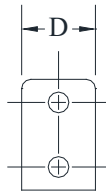

FIG. 1

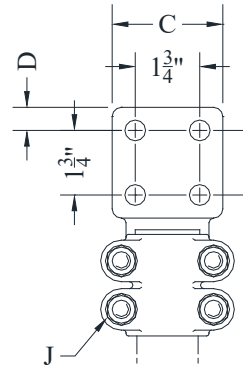
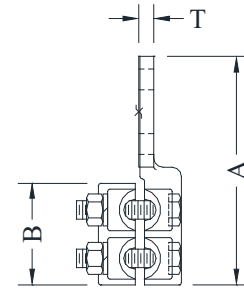

FIG. 2



CATALOG NUMBER	FIG. NO.	PIPE SIZE (NPS)	DIMENSIONS - INCHES						WEIGHT (POUNDS)
			A	B	C	D	J	T	
FNTTC-21-2B	1	1/2	5-1/2	2	2	5/8	3/8	1/4	2.60
FNTTC-21-4A	2		5-1/2	2	3	5/8	3/8	1/4	2.60
FNTTC-30-2B	1	3/4	5-5/8	2	2	5/8	3/8	5/16	1.80
FNTTC-30-4A	2		6-1/16	2-3/8	3	5/8	3/8	3/8	2.60
FNTTC-39-2B	1	1	6	2-1/2	2	5/8	3/8	3/8	2.90
FNTTC-39-4A	2		6-1/8	2-1/2	3	5/8	3/8	3/8	3.15
FNTTC-39-4B	2		7-1/8	2-1/2	4	1-1/8	3/8	3/8	3.30
FNTTC-49-2B	1	1-1/4	6-3/16	2-3/4	2	5/8	1/2	3/8	4.50
FNTTC-49-4A	2		6-3/16	2-3/4	3	5/8	1/2	3/8	4.50
FNTTC-49-4B	2		7-7/16	3	4	1-1/8	1/2	1/2	7.45
FNTTC-53-2B	1	1-1/2	6-7/16	2-13/16	2	5/8	1/2	7/16	5.10
FNTTC-53-4A	2		6-1/2	2-13/16	3	5/8	1/2	3/8	5.10
FNTTC-53-4B	2		7-5/8	2-13/16	4	1-1/8	1/2	3/8	5.35
FNTTC-58-2B	1	2	7-5/16	3-1/2	2	5/8	1/2	1/2	9.00
FNTTC-58-4A	2		6-11/16	3	3	5/8	1/2	7/16	6.70
FNTTC-58-4B	2		8-5/16	3-1/2	4	1-1/8	1/2	1/2	9.00
FNTTC-60-2B	1	2-1/2	6-5/8	3	2	5/8	1/2	9/16	6.80
FNTTC-60-4A	2		6-5/8	3	3	5/8	1/2	9/16	6.80
FNTTC-60-4B	2		8	3-1/2	4	1-1/8	1/2	1/2	9.40
FNTTC-62-2B	1	3	7-1/2	4	2	5/8	5/8	5/8	15.50
FNTTC-62-4A	2		8	4	3	5/8	5/8	5/8	15.50
FNTTC-62-4B	2		8-1/2	4	4	1-1/8	5/8	5/8	15.50
FNTTC-63-4A	2	3-1/2	7-3/16	3-1/2	3	5/8	5/8	3/4	15.40
FNTTC-63-4B	2		8-1/16	3-1/2	4	1-1/8	5/8	3/4	15.40
FNTTC-64-4A	2	4	8-5/8	4-1/2	3	5/8	5/8	3/4	20.65
FNTTC-64-4B	2		9-5/8	4-1/2	4	1-1/8	5/8	3/4	20.65
FNTTC-67-4B	2	5	10-1/2	5	4	1-1/8	5/8	1	20.60

BRONZE TERMINALS

TYPE FNXT

Expansion
Pipe to Flat Pad

Bronze alloy expansion terminal with hex head clamping bolts for connecting copper pipe to flat. Clamping bolts have hex stops for one-wrench installation. Flat pads have NEMA drilling. Connectors available with transverse 90° pad orientation. Add "V" to catalog number. Example: FNXT-V-58-4A

Casting Alloy: Electrical Bronze
Clamping Hardware: Silicon Bronze
Laminated Straps: Copper
Options: See Page 123

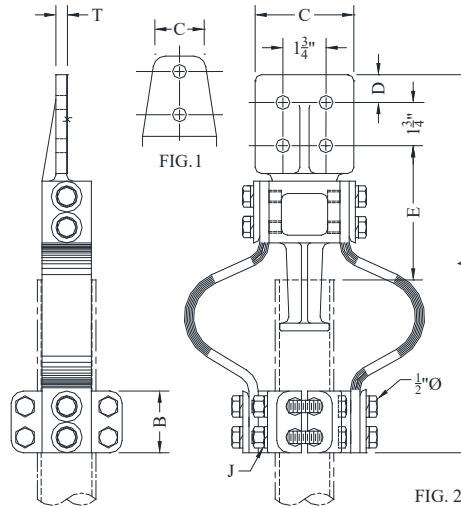

CATALOG NUMBER	FIG. NO.	PIPE SIZE (NPS)	DIMENSIONS - INCHES							WEIGHT (POUNDS)
			A	B	C	D	E	J	T	
FNXT-30-2B	1	3/4	11-3/4	3	2	5/8	3-7/8	3/8	3/8	8.75
FNXT-30-4A	2		11-3/4	3	3	5/8	3-7/8	3/8	3/8	8.75
FNXT-39-2B	1	1	13	3	2	5/8	4-3/8	3/8	3/8	10.25
FNXT-39-4A	2		13	3	3	5/8	4-3/8	3/8	3/8	10.25
FNXT-49-2B	1	1-1/4	13-5/16	2-1/2	2	5/8	4-3/4	1/2	3/8	12.80
FNXT-49-4A	2		13-5/16	2-1/2	3	5/8	4-3/4	1/2	3/8	12.80
FNXT-49-4B	2		14-5/16	2-1/2	4	1-1/8	4-3/4	1/2	3/8	13.00
FNXT-53-2B	1	1-1/2	15	3-1/2	2	5/8	5-1/8	1/2	7/16	16.15
FNXT-53-4A	2		15	3-1/2	3	5/8	5-1/8	1/2	7/16	16.15
FNXT-53-4B	2		16	3-1/2	4	1-1/8	5-5/8	1/2	7/16	16.15
FNXT-58-2B	1	2	14-5/16	2-1/2	2	5/8	5-7/16	1/2	7/16	24.70
FNXT-58-4A	2		14-5/16	2-1/2	3	5/8	5-7/16	1/2	7/16	24.75
FNXT-58-4B	2		15-5/16	2-1/2	4	1-1/8	5-7/16	1/2	7/16	24.70
FNXT-60-4A	2	2-1/2	18-1/8	3-3/4	3	5/8	5-5/8	1/2	5/8	34.60
FNXT-60-4B	2		19-1/8	3-3/4	4	1-1/8	5-5/8	1/2	1/2	32.20
FNXT-62-4A	2	3	15-3/8	3	3	5/8	5-3/8	5/8	11/16	39.15
FNXT-62-4B	2		16-3/8	3	4	1-1/8	5-3/8	5/8	11/16	39.15
FNXT-63-4A	2	3-1/2	15-3/8	3	3	5/8	5-7/8	5/8	3/4	47.05
FNXT-63-4B	2		16-3/8	3	4	1-1/8	5-7/8	5/8	3/4	47.05
FNXT-64-4A	2	4	18-3/8	4	3	5/8	5-1/2	5/8	3/4	45.05
FNXT-64-4B	2		19-3/8	4	4	1-1/8	6	5/8	3/4	53.15

BRONZE TERMINALS

TYPE SFFT

Expansion
Pipe to Flat Pad

Bronze alloy semi-flexible laminated terminal with hex head clamping bolts for connecting copper pipe to flat. Clamping bolts have hex-stops for one-wrench installation. Laminated straps are factory bolted to connector tongue. Tongue and strap holes have NEMA drilling.

NOTE: This connector is not recommended as a support member.

Casting Alloy: Electrical Bronze
Clamping Hardware: Silicon Bronze
Laminated Straps: Copper
Options: See Page 123

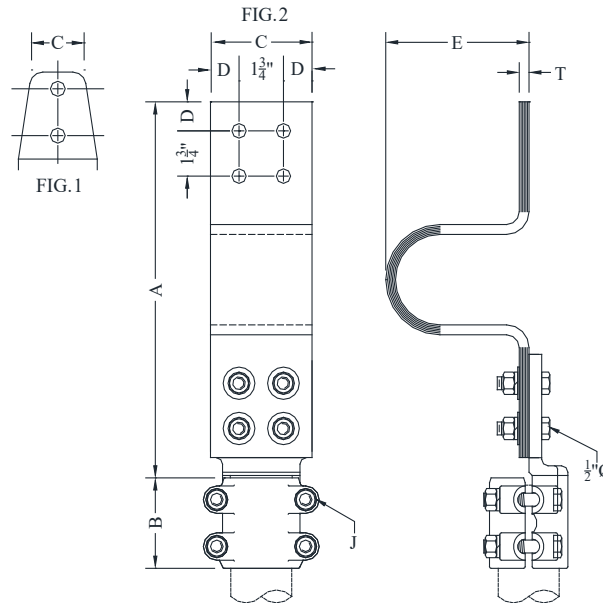

CATALOG NUMBER	FIG. NO.	PIPE SIZE (NPS)	DIMENSIONS - INCHES							WEIGHT (POUNDS)
			A	B	C	D	E	T	J	
SFFT-21-2B	1	1/2	12	2	2	5/8	5-1/8	1/4	3/8	5.50
SFFT-30-2B	1	3/4	12	2-1/2	2	5/8	5-1/8	1/4	3/8	5.75
SFFT-30-4A	2		13-7/8	2	3	5/8	5-1/4	1/4	3/8	8.25
SFFT-39-2B	1	1	14-1/4	2	2	5/8	6-1/4	1/4	3/8	9.55
SFFT-39-4A	2		14-1/4	2	3	5/8	6-1/4	1/4	3/8	9.55
SFFT-49-2B	1	1-1/4	12-7/8	2-3/4	2	5/8	7-1/4	5/16	1/2	12.55
SFFT-49-4A	2		12-7/8	2-3/4	3	5/8	7-1/4	5/16	1/2	12.55
SFFT-53-2B	1	1-1/2	15-19/32	2-3/4	2	5/8	7-1/4	5/16	1/2	13.20
SFFT-53-4A	2		15-23/32	2-3/4	3	5/8	7-3/8	3/8	1/2	15.05
SFFT-53-4B	2		17-1/32	2-3/4	4	1-1/8	6-3/4	1/4	1/2	14.10
SFFT-58-2B	1	2	13	3	2	5/8	7-3/8	3/8	1/2	16.50
SFFT-58-4A	2		13	3	3	5/8	7-3/8	3/8	1/2	16.65
SFFT-58-4B	2		14-1/2	3-1/2	4	1-1/8	5-5/8	3/8	1/2	20.55
SFFT-60-4A	2	2-1/2	12-3/4	3-1/2	3	5/8	7-1/4	1/2	1/2	20.25
SFFT-60-4B	2		18-1/8	3-1/2	4	1-1/8	7-1/8	9/16	1/2	26.55
SFFT-62-4A	2	3	17-1/16	3-3/4	3	5/8	7-1/4	1/2	5/8	22.40
SFFT-62-4B	2		14-7/8	4	4	1-1/8	8-1/2	5/8	5/8	39.05
SFFT-63-4A	2	3-1/2	16-15/16	3-1/2	3	5/8	7-1/2	5/8	5/8	31.55
SFFT-63-4B	2		15-1/16	3-1/2	4	1-1/8	7-3/4	3/4	5/8	42.05
SFFT-64-4A	2	4	14-5/8	4-1/2	3	5/8	7-3/4	3/4	5/8	40.20
SFFT-64-4B	2		15-5/8	4-1/2	4	1-1/8	7-3/4	3/4	5/8	47.30

BRONZE TERMINALS

TYPE SFFT90

Expansion
Pipe to Flat Pad

Casting Alloy: Electrical Bronze
Clamping Hardware: Silicon Bronze
Laminated Straps: Copper
Options: See Page 123

Bronze alloy semi-flexible laminated terminal with hex head clamping bolts for connecting copper pipe to flat. Clamping bolts have hex-stops for one-wrench installation. Laminated straps are factory bolted to connector tongue. Tongue and strap holes have NEMA drilling.
NOTE: This connector is not recommended as a support member.

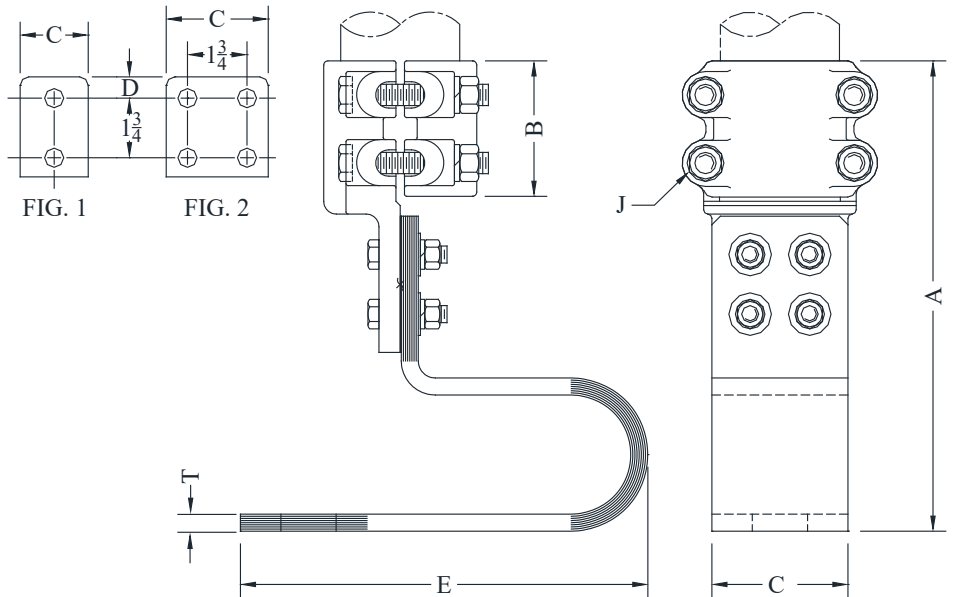

CATALOG NUMBER	FIG. NO.	PIPE SIZE (NPS)	DIMENSIONS - INCHES							WEIGHT (POUNDS)
			A	B	C	D	E	T	J	
SFFT90-30-2B	1	3/4	10-3/4	2-3/8	2	5/8	8	1/4	3/8	8.40
SFFT90-30-4A	2		10-3/4	2-3/8	3	5/8	8	1/4	3/8	8.40
SFFT90-39-2B	1	1	10-1/4	2	2	5/8	8-1/8	3/8	3/8	11.40
SFFT90-39-4A	2		10-1/4	2	3	5/8	8-1/8	3/8	3/8	11.40
SFFT90-49-2B	1	1-1/4	11-1/8	2-7/8	2	5/8	8-1/8	3/8	1/2	10.30
SFFT90-49-4A	2		11-5/8	2-3/4	3	5/8	8-1/8	3/8	1/2	13.50
SFFT90-53-2B	1	1-1/2	12-9/16	2-13/16	2	5/8	11	3/8	1/2	11.70
SFFT90-53-4A	2		11	2-3/4	3	5/8	8-1/8	3/8	1/2	13.50
SFFT90-53-4B	2		12-3/8	2-13/16	4	1-1/8	12-7/8	3/8	1/2	18.95
SFFT90-58-2B	1	2	11-3/4	3	2	5/8	8-1/8	3/8	1/2	15.15
SFFT90-58-4A	2		11-3/4	3	3	5/8	8-1/8	3/8	1/2	15.15
SFFT90-58-4B	2		13-1/2	3-1/2	4	1-1/8	12-7/8	3/8	1/2	22.65
SFFT90-60-4A	2	2-1/2	13-5/8	3-1/2	3	5/8	12-7/8	1/2	1/2	21.60
SFFT90-60-4B	2		13	3-1/2	4	1-1/8	12-7/8	1/2	1/2	27.35
SFFT90-62-4A	2	3	13-13/16	4	3	5/8	12	3/4	5/8	37.25
SFFT90-62-4B	2		14-3/16	4	4	1-1/8	12-7/8	3/4	5/8	41.65
SFFT90-63-4A	2	3-1/2	13-3/4	3-1/2	3	5/8	12-7/8	3/4	5/8	35.90
SFFT90-63-4B	2		13-3/4	3-1/2	4	1-1/8	12-7/8	3/4	5/8	42.10
SFFT90-64-4A	2	4	15-3/8	4-1/2	3	5/8	12-7/8	3/4	5/8	40.60
SFFT90-64-4B	2		15-3/8	4-1/2	4	1-1/8	12-7/8	3/4	5/8	46.80

BRONZE TERMINALS

TYPE SXR/SXR2

Straight or 90° Bolted
Terminal to Cable or Pipe

Bronze bolted terminal that can be used for straight or 90° connections to cable or pipe to flat bar or terminal pad.

NOTE: SXR-34 and SXR2-34 NEMA drilling.
SXR-48 and SXR2-48 Non-NEMA drilling

Casting Alloy: Electrical Bronze
Clamping Hardware: Silicon Bronze

CATALOG NUMBER	CONDUCTOR RANGE	
	CABLE	NPS
NEMA DRILLING		
SXR-34	#2 - 1000 MCM	3/8" - 3/4"
SXR2-34	(2) #2 - 1000 MCM	3/8" - 3/4"
NON-NEMA DRILLING		
SXR-48	#2 - 2000 MCM	3/8" - 1"
SXR2-48	(2) #2 - 2000 MCM	3/8" - 1"

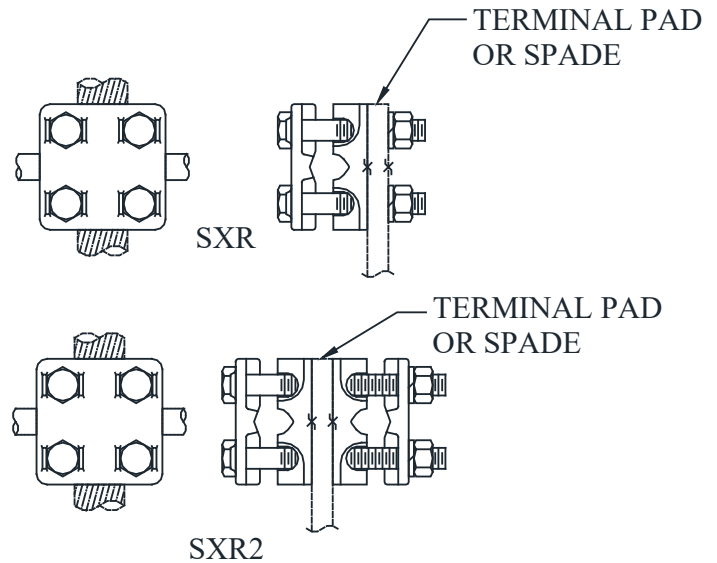

Consult manufacturer for further details or unlisted applications.

TYPE FNXR

Dual Function
Tee Connector/Terminal
Cable or Pipe

Bronze bolted, dual function tee/terminal for cable or pipe connections to flat pad tap. Reversible cap allows a wide range conductor, straight or 90° to a 2 or 4 hole NEMA flat.

Casting Alloy: Electrical Bronze
Clamping Hardware: Silicon Bronze

CATALOG NUMBER	FIG. NO.	WIDTH IN.	T	CONDUCTOR RANGE	
				CABLE	NPS
FNXR-0139-2B	2	2	1/2	#8 - 1300 MCM	1/4" - 1"
FNXR-0139-4A	1	3	3/8	#8 - 1300 MCM	1/4" - 1"
FNXR-0420-2B	2	2	3/8	#4 - 500 MCM	1/4" - 3/8"
FNXR-39-2B	2	2	1/2	350 - 1500 MCM	1/2" - 1"
FNXR-39-4A	1	3	1/2	350 - 1500 MCM	1/2" - 1"
FNXR-48-4A	1	3	3/4	#2 - 2000 MCM	1/2" - 1"
FNXR-48-4B	1	4	3/4	#2 - 2000 MCM	1/2" - 1"

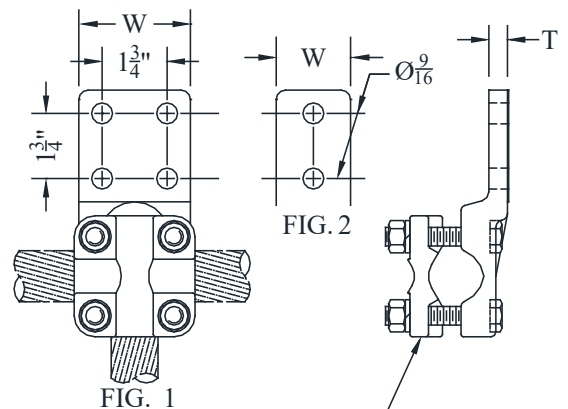

CAP MAY BE TURNED OR REVERSED TO CLAMP CONDUCTOR WITHIN RANGE SHOWN.

BRONZE TERMINALS

TYPE UK

Adjustable U-Bolt
Cable to Flat Pad

Castings: Electrical Bronze
Clamping Hardware: Silicon Bronze
Options: See Page 123

Bronze alloy U-bolt type terminal for connecting copper cable to copper flat. Flat pads have NEMA drilling.

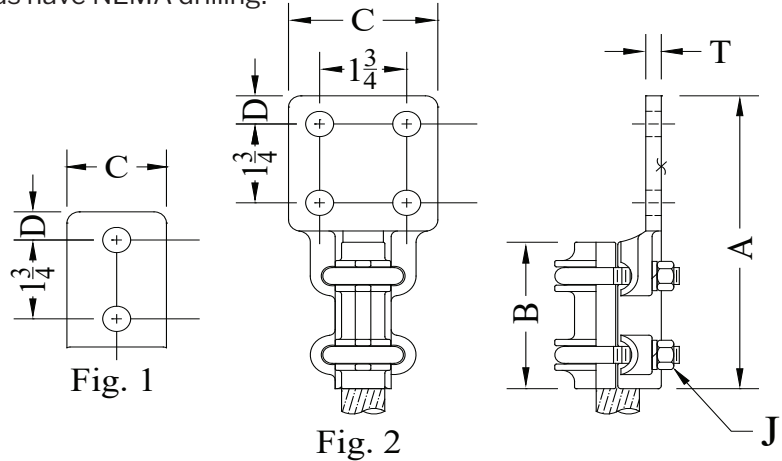

CATALOG NUMBER	FIG. NO.	CONDUCTOR RANGE	DIMENSIONS - INCHES						WEIGHT (POUNDS)
			A	B	C	D	J	T	
UK-4052-4	2	#8 STR - 300 MCM	6-1/4	3-1/4	3	5/8	3/8	1/4	1.90

TYPE UKG

Through type U-Bolt
Cable to Flat

Castings: Electrical Bronze
Clamping Hardware: Silicon Bronze
Options: See Page 123

Bronze alloy U-bolt type terminal for connecting copper cable to flat. Especially suitable for mounting on large flat surfaces. Often applied as a grounding connector.

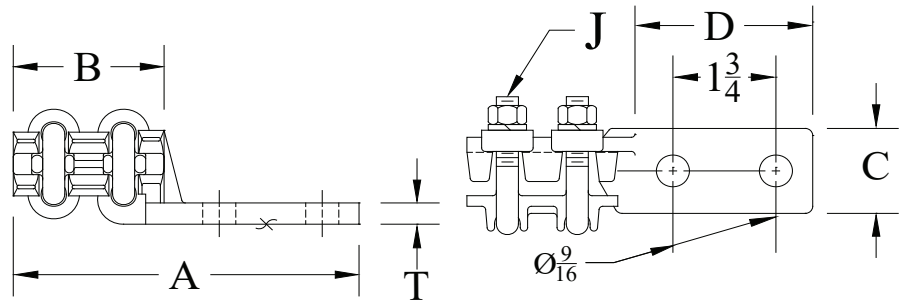

CATALOG NUMBER	CONDUCTOR RANGE	DIMENSIONS - INCHES						WEIGHT (POUNDS)
		A	B	C	D	J	T	
UKG-4052	#8 STR - 300 MCM	6-1/4	2-9/16	1-1/2	3	3/8	5/16	1.70

TYPE UKL

U-Bolt type
Cable to Flat

Castings: Electrical Bronze
Clamping Hardware: Silicon Bronze
Options: See Page 123

Bronze alloy U-bolt type terminal for connecting copper cable to flat.

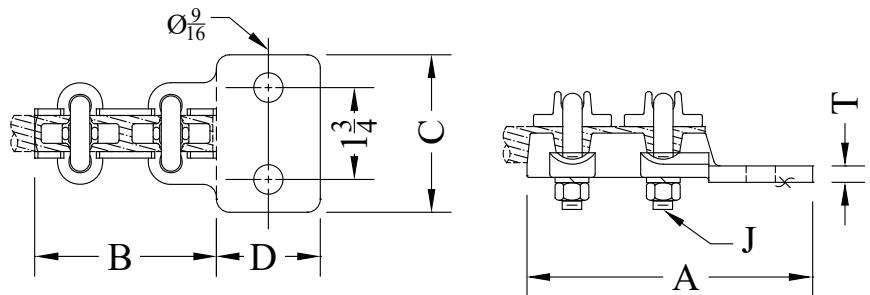

CATALOG NUMBER	CONDUCTOR RANGE	DIMENSIONS - INCHES						WEIGHT (POUNDS)
		A	B	C	D	J	T	
UKL-4052	#8 STR - 300 MCM	5-1/2	3-1/4	3	2	3/8	5/16	1.60

BRONZE TERMINALS

TYPE UMX

Bronze Eye-Bolt
Terminal

Casting Alloy: Electrical Bronze
Eye-Bolt: Aluminum Bronze / Tinned

Bronze single Eye-bolt terminal for connecting copper cable to copper flat.
Consult manufacturer for further details or unlisted applications.
Cable entrance straight on or 90° to flat.

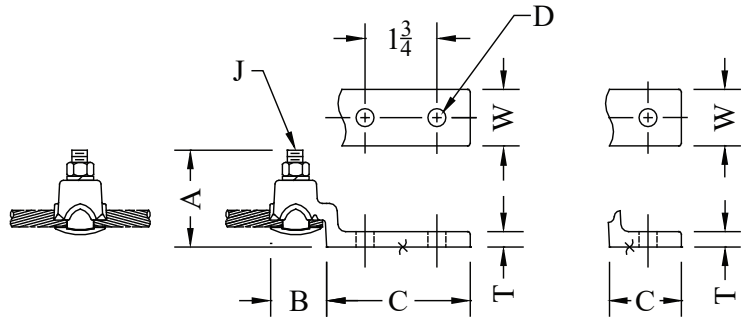

CATALOG NUMBER	CONDUCTOR RANGE	HOLES IN PAD	DIMENSIONS - INCHES						
			A	B	C	D	J	W	T
UMX-4048-1	#8 SOL - 2/0 STR	1	2-5/8	1-3/8	1-3/8	7/16	3/8	3/4	5/16
UMX-4151-1	#6 - 250 MCM	1	2-15/16	2-15/16	1-1/4	9/16	1/2	1-3/8	5/16
UMX-4151-2N	#6 - 250 MCM	2	3-1/4	2-15/16	3	9/16	1/2	1-3/8	5/16
UMX-4756-1	1/0 STR - 500 MCM	1	3-3/16	3-1/8	1-5/8	9/16	1/2	1-3/8	3/8
UMX-4756-2N	1/0 STR - 500 MCM	2	3-7/8	3-5/16	3	9/16	1/2	2	3/8

TYPE FNSS

Single Bolted Terminal
Cable to Flat

Material: Electrical Bronze
Hardware: Silicon Bronze

Bronze single bolted vise type terminal for use in copper cable to flat pad applications.
Contact factory for further information

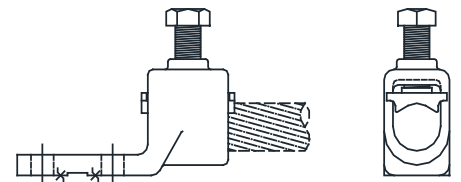
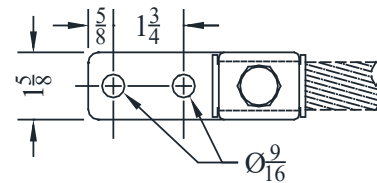

CATALOG NUMBER	CONDUCTOR RANGE
FNSS-20-2A	4/0 - 500 MCM
FNSS-34-2A	500 - 1000 MCM

TYPE GLT-12

Equipment Grounding
Terminal

Castings: Electrical Bronze
Hardware: Silicon bronze

A through-type grounding terminal for apparatus grounding pads having tapped holes on a NEMA 2-hole pattern. Connector allows continuity of the ground conductor where required.
Conductor sizes: #6 STR through 250 MCM.

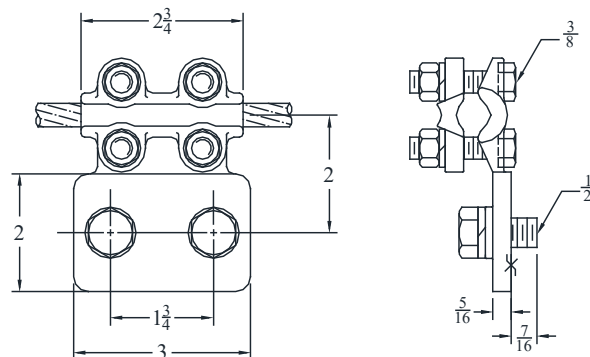

BRONZE TERMINALS

TYPE UN

Eye-Bolt Connector
Cable to Flat Pad

Casting Alloy: Electrical Bronze
Clamping Hardware: Silicon Bronze
Eye-Bolt: Aluminum Bronze/Tinned

All-bronze ground connector for single cable to flat bar. For tin plating, add suffix (-SND) to catalog number. Not recommended for use with aluminum conductor.

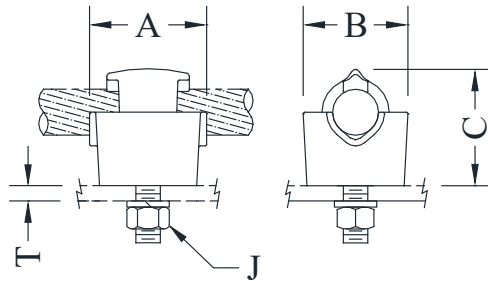

CATALOG NUMBER	CONDUCTOR RANGE	DIMENSIONS - INCHES					WEIGHT (POUNDS)
		A	B	C	J	T	
UN-4048	#8 SOL - 2/0 STR	1-3/4	1-1/4	1-9/16	1/2	5/16	0.55
UN-4048T		1-3/4	1-1/4	1-9/16	1/2	3/4	0.55
UN-4151	#6 STR - 250 MCM	1-5/8	1-1/2	1-13/16	1/2	1/2	0.75
UN-4151T		1-5/8	1-1/2	1-13/16	1/2	1-1/8	0.75
UN-4553	#2 SOL - 350 MCM	1-7/8	1-3/4	2-3/16	1/2	5/16	0.75
UN-4553T		1-7/8	1-3/4	2-3/16	1/2	3/4	0.75
UN-4656	1/0 SOL - 500 MCM	2-1/8	2	2-1/2	5/8	5/16	1.00
UN-4656T		2-1/8	2	2-1/2	5/8	3/4	1.00

TYPE UNN

Eye-Bolt Connector
Cable to Flat Pad

Casting Alloy: Electrical Bronze
Clamping Hardware: Silicon Bronze
Eye-Bolt: Aluminum Bronze/Tinned

All-bronze ground connector for use as single-cable double-grip or two-cable single-grip to flat to bar. For tin plating, add suffix (-SND) to catalog number. Not recommended for use with aluminum conductor.

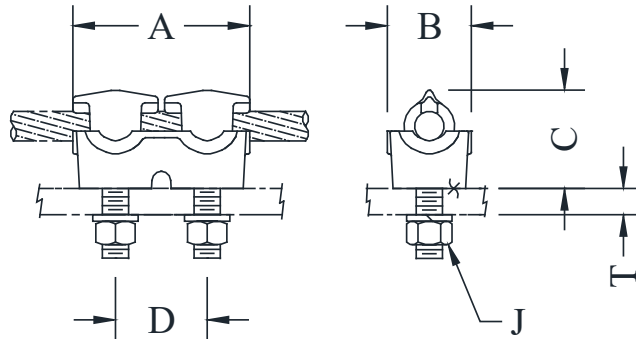

CATALOG NUMBER	CONDUCTOR RANGE	DIMENSIONS - INCHES						WEIGHT (POUNDS)
		A	B	C	D	J	T	
UNN-4048	#8 SOL - 2/0 STR	3-1/2	1-3/4	1-5/8	1-3/4	1/2	5/16	0.80
UNN-4048T							3/4	0.80
UNN-4151	#6 STR - 250 MCM	3-1/2	1-3/4	1-7/8	1-3/4	1/2	5/16	1.50
UNN-4151T							3/4	1.50
UNN-4553	#2 SOL - 350 MCM	3-5/8	1-7/8	2-3/16	1-3/4	1/2	5/16	1.65
UNN-4553T							3/4	1.65
UNN-4656	1/0 SOL - 500 MCM	4-1/8	2-3/8	2-3/8	1-3/4	1/2	5/16	2.15
UNN-4656T							3/4	2.15
*UNN-5361	350 MCM - 750 MCM	3-5/8	2-1/8	2-1/2	1-3/4	1/2	5/16	2.30
*UNN-5361T							3/4	2.30

* Single-cable, double-grip only.

SEFCOR

EHV TERMINALS



AFNCHV



WFCHV



WFC2HV



AFNTCHV



WFTCHV



WFTICHV



WHV-FXT



ADPHV-4B



AFN3HV



AFBV



AFBH

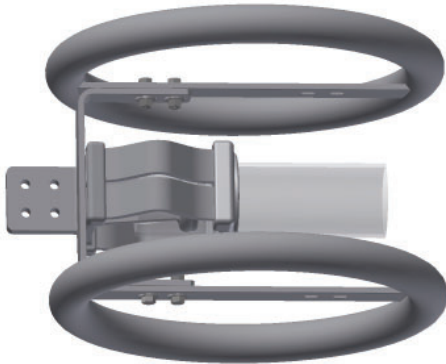

WFXTC-V-CS



WFCCH

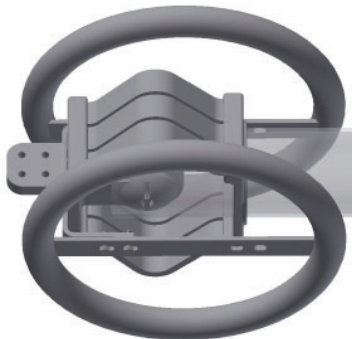

WFRTC-V



WFCCV

EHV TERMINALS

SEFCOR EHV terminals are corona-free for 345kV and 500kV applications. Both with high-voltage laboratory testing and with years of time-proven trouble-free operating service, our EHV terminals attest to the superiority of the SEFCOR designs.

All aluminum castings are poured from 356 aluminum alloy and heat-treated to T6 temper.

This section is arranged in the following sequence for the convenience of the user:

Cable to Flat Pad
Pipe to Flat Pad
Expansion

OPTIONS

A suffix added to a catalog number denotes a variation or option made to the standard cataloged item. The suffixes listed below display the various options available with SEFCOR EHV terminals. Consult manufacturer for further details, unlisted and/or special applications.

- E - Extension pad
- HS - With pad hardware shields
- MB - With tongue mounting hardware
- NS - No hardware shield when normally furnished

NOTES;

1. Actual dimensions (other than those established by NEMA) of connectors shown may vary slightly. If exact dimensions are required, refer to factory or see assembly drawing.
2. Consult manufacturer for further details or unlisted applications.

EHV TERMINALS

TYPE AFN3HV

Trifurcating
Flat Pad to Flat Pad

Designed for corona-free service at 500kV when used with three EHV cable terminals to form a trifurcating terminal connection. No additional hardware shields are required when assembling bolts are installed with the nuts inside the bell. Hardware must be ordered separately.

Casting Alloy: 356-T6 Aluminum
Options: See Page 140

ALUMINUM • 500kV

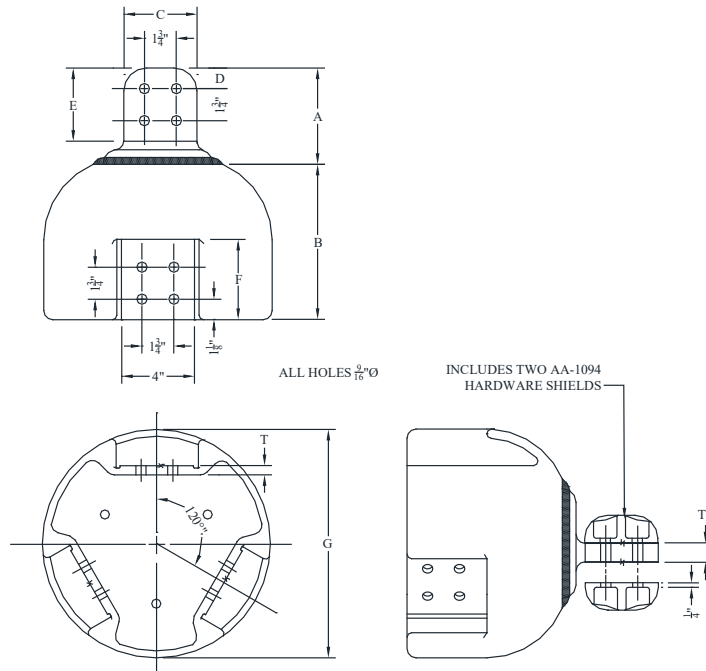

CATALOG NUMBER	DIMENSIONS - INCHES									WEIGHT (POUNDS)
	A	B	C	D	E	F	G	T	T1	
AFN3HV	5-1/4	8-1/2	4	1-1/8	4	4-3/8	12-1/2	1/2	1	33.75

TYPE ADPHV-4B

Extension Pad
3000 A

Designed for use at 500kV where additional clearance is required at termination on shielded apparatus pads. For in line connections only.

Casting Alloy: 356-T6 Aluminum
Options: See Page 140

ALUMINUM • 500kV

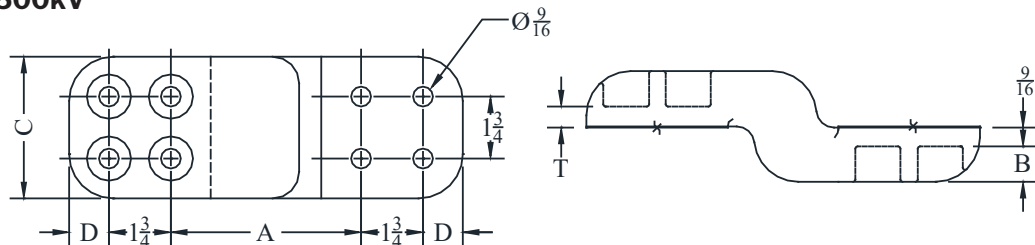

CATALOG NUMBER	DIMENSIONS - INCHES					WEIGHT (POUNDS)
	A	B	C	D	T	
ADPHV-4B	5-3/8	1	4	1-1/8	9/16	6.95

EHV TERMINALS

TYPE AFNCHV

Straight Bolted
Cable to Flat Pad

Casting Alloy: 356-T6 Aluminum
Clamping Hardware: Aluminum Alloy
Options: See Page 140

ALUMINUM • 345 - 500kV

Designed for corona-free service within the voltage limitations of the cable conductor. Contact surfaces are finished and coated with a sealant prior to packaging in plastic bags for shipment. Hardware shield is not included. To obtain hardware shield as part of the terminal assembly add suffix (HS) to catalog number. Example: AFNCHV-56-4B-HS

Note: See hardware shield AA-1094.

Multi-conductor options are also available by specifying the number of cables. Example: AFNCHV2-36-4B

Angled connectors may be obtained by specifying the desired angle.

Example: AFNCHV-90-34-4B

These options may be combined to obtain an angled, multi-conductor connector.

Example: AFNC3HV-90-34-4B

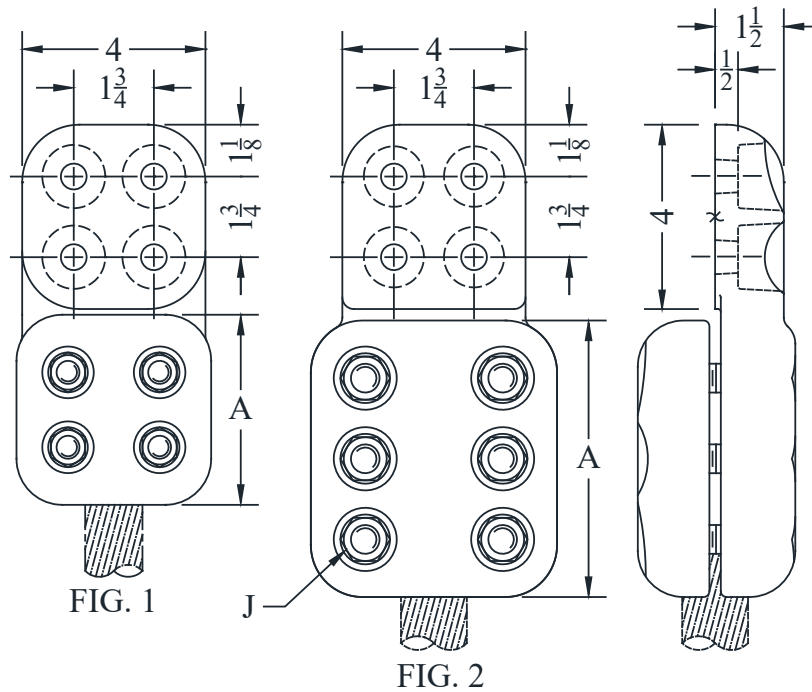

CATALOG NUMBER	FIG. NO.	CONDUCTOR SIZE (MCM)		DIMENSIONS - INCHES		WEIGHT (POUNDS)
		AAC	ACSR	A	J	
AFNCHV-34-4B	1	954 - 1000	795	3-3/4	1/2	3.50
AFNCHV-35-4B	1	1033.5	874.5	3-3/4	1/2	3.50
AFNCHV-36-4B	1	1113	954	4-1/8	1/2	5.00
AFNCHV-39-4B	1	1192 - 1272	1033 - 1113	4-1/8	1/2	4.25
AFNCHV-41-4B	1	1431	1272	4-1/4	1/2	5.00
AFNCHV-43-4B	1	1590	1351 - 1431	4-1/4	5/8	5.05
AFNCHV-46-4B	2	1800	1590	6	5/8	9.60
AFNCHV-49-4B	2	2000 - 2303.5	2034 - 2167	6	5/8	8.10
AFNCHV-52-4B	2	2500	2156	6	5/8	7.75
AFNCHV-56-4B	2	3500	----	6-1/4	5/8	9.00

EHV TERMINALS

TYPE AFNTC-HV

Straight Bolted
Pipe to Flat Pad

Casting Alloy: 356-T6 Aluminum
Clamping Hardware: Aluminum Alloy
Options: See Page 140

Designed for corona-free service at 345kV and 500kV as indicated.
Contact surfaces are finished and coated with a sealant prior to packing in plastic bags for shipment.
Hardware shield is not included.
To obtain hardware shield as part of the terminal assembly, add suffix (HS) to catalog number.
Example: AFNTC-HV-69-4B-HS
Note: See hardware shield AA-1094.

ALUMINUM • 345 - 500kV

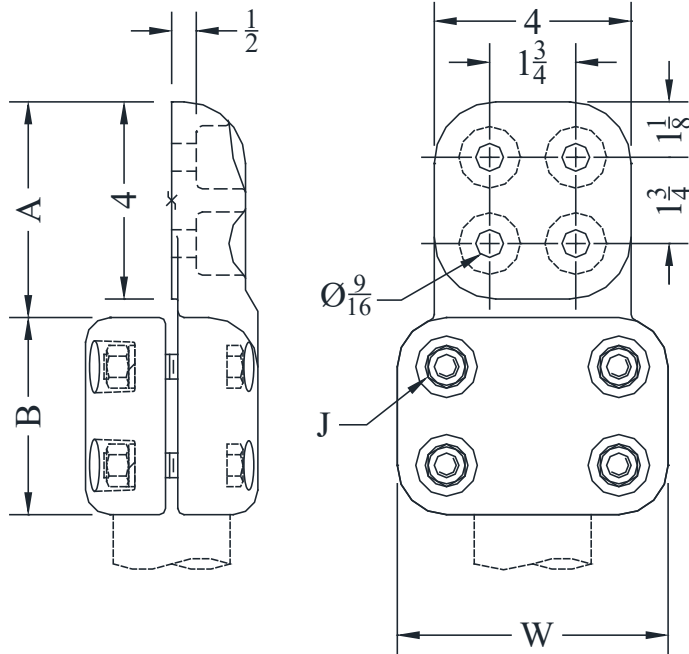

FIG. 1

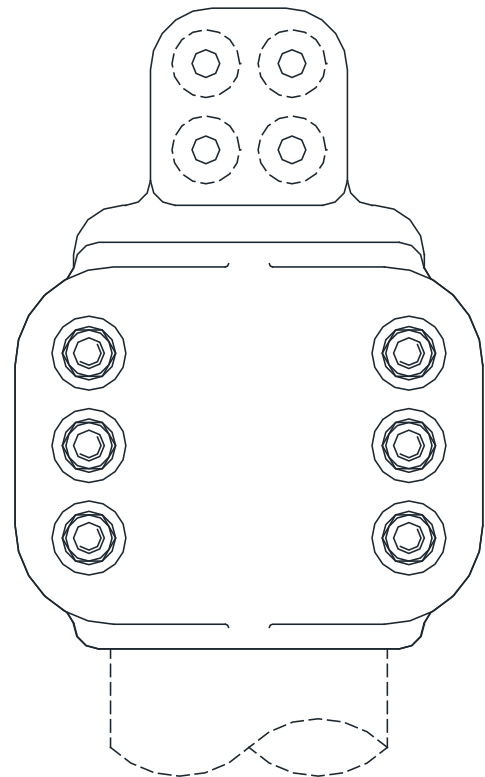

FIG. 2

CATALOG NUMBER	FIG. NO.	PIPE SIZE (NPS)	MAX KV	DIMENSIONS - INCHES				WEIGHT (POUNDS)
				A	B	W	J	
AFNTC-HV-58-4B	1	2	345	4-3/8	4	5-1/2	1/2	5.25
AFNTC-HV-60-4B	1	2-1/2	345	4-5/8	4-1/2	7-1/4	5/8	12.00
AFNTC-HV-62-4B	1	3	345	4-7/5	4-1/2	7-1/4	5/8	10.80
AFNTC-HV-63-4B	1	3-1/2	500	4-1/2	5	7-1/8	5/8	11.15
AFNTC-HV-64-4B	1	4	500	4-3/4	4-1/2	8-1/2	5/8	11.15
AFNTC-HV-67-4B	2	5	500	4-3/4	8-1/4	9-1/2	5/8	22.35
AFNTC-HV-69-4B	2	6	500	5-1/8	7	9-7/8	5/8	24.70

SEFCOR

EHV TERMINALS

TYPE WFCHV

Weldment

Cable to Flat Pad

Casting Alloy: 356-T6 Aluminum
Options: See Page 140

ALUMINUM • 345kV

Designed for corona-free service at 345kV, either singly or paired back-to-back as noted.

Pads are finished both sides.

One hardware shield is furnished as part of the catalog number.

Where an additional shield is required, add suffix (HS) to catalog number.

For 90° pad angle, add suffix (90) to the catalog number.

Example: WFCHV-90-52-4B.

Note: See hardware shield AA-1094.

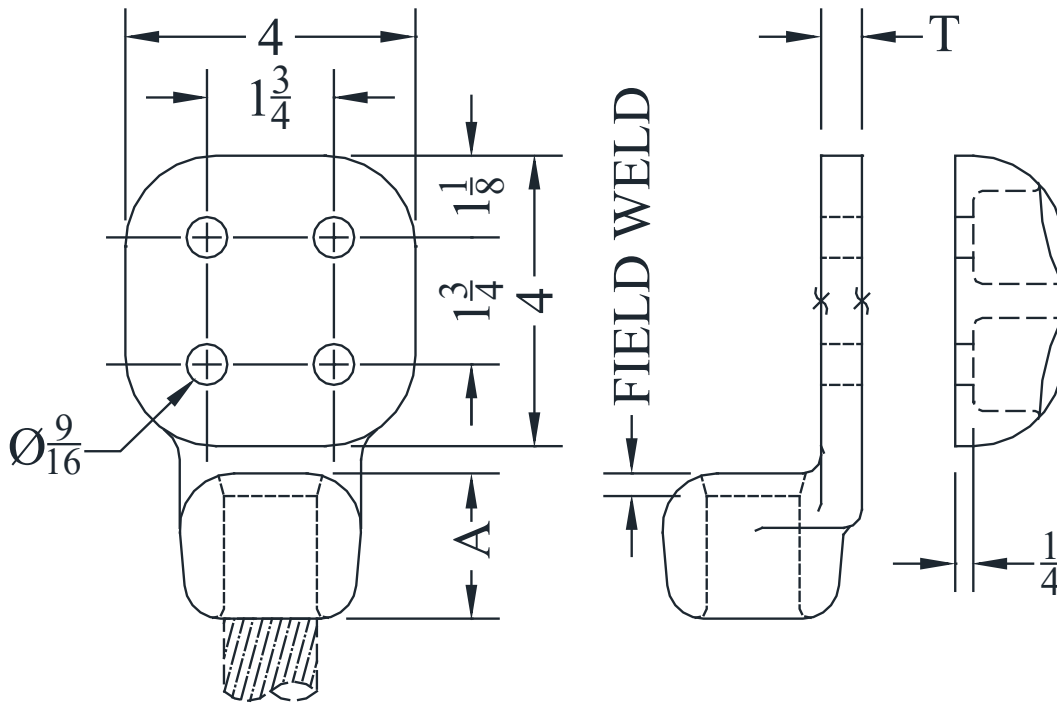

CATALOG NUMBER	CONDUCTOR SIZE (MCM)		DIMENSIONS - INCHES		WEIGHT (POUNDS)
	AAC	ACSR	A	T	
WFCHV-29-4B	795	636 - 666	1-7/8	1/2	2.65
WFCHV-34-4B	954 - 1033	795	2	1/2	2.80
WFCHV-36-4B	1113	954	2	9/16	2.90
WFCHV-37-4B	1113 - 1272	1027 - 1192	2	9/16	2.90
WFCHV-39-4B	1250 - 1300	1113 - 1192	2-1/4	5/8	2.90
WFCHV-41-4B	1250 - 1510	1192 - 1272	2-3/8	3/4	2.90
WFCHV-43-4B	1590	1351 - 1431	2-5/8	3/4	3.60
WFCHV-46-4B	1750	1590	2-5/8	3/4	3.90
WFCHV-49-4B	2000	1780 - 2034	2-3/4	3/4	3.60
WFCHV-52-4B	2500	2312	2-3/4	7/8	5.10
WFCHV-56-4B	3500	----	3	1-1/8	6.00

SEFCOR

EHV TERMINALS

TYPE WFC2HV

Weldment

Two Cable to Flat Pad

Casting Alloy: 356-T6 Aluminum
Options: See Page 140

ALUMINUM • 345 - 500kV

Designed for corona-free service at 345 and 500kV, either singly or paired back-to-back as noted. Pads are finished both sides. One hardware shield is furnished as part of the catalog number. Where an additional shield is required, add suffix (HS) to catalog number.

For 90° pad angle, add (90) to the catalog number.

Example: WFC2HV90-52-4B-HS.

Note: See hardware shield AA-1094 or HS-6B.

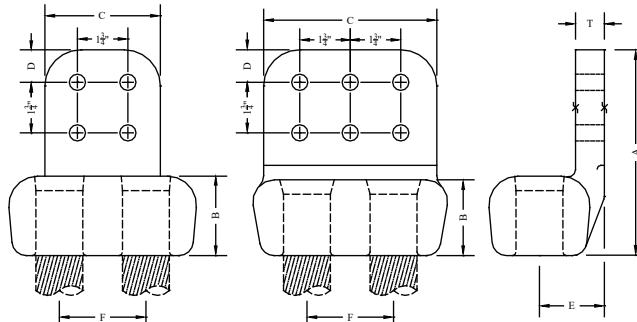

FIG. 1

FIG. 2

CATALOG NUMBER	FIG NO.	CONDUCTOR RANGE (MCM)		DIMENSIONS - INCHES							WEIGHT (POUNDS)
		AAC	ACSR	A	B	C	D	E	F	T	
WFC2HV-29-4B	1	795	636 - 666	6-3/16	1-13/16	4	1-1/8	1-11/16	2	3/4	4.125
WFC2HV-34-4B	1	954 - 1000	795	7-1/8	2-3/4	4	1-1/8	1-3/4	2	7/8	4.125
WFC2HV-36-4B	1	1033 - 1113	954	6-1/2	2	4	1-1/8	1-7/8	2-1/2	3/4	4.625
WFC2HV-37-4B	1	1113 - 1192	1033.5	6-1/2	2	4	1-1/8	1-7/8	2-1/2	3/4	4.625
WFC2HV-39-4B	1	1250 - 1300	1113 - 1192	6-1/2	2	4	1-1/8	1-7/8	2-1/2	3/4	4.625
WFC2HV-39-6B	2			6-1/2	2	6	1-1/8	1-7/8	2-1/2	3/4	6.500
WFC2HV-41-4B	1	1351 - 1431	1192 - 1272	6-7/8	2-1/2	4	1-1/8	1-3/4	2-1/2	3/4	3.625
WFC2HV-41-6B	2			6-7/8	2-1/2	6	1-1/8	1-3/4	2-1/2	3/4	6.400
WFC2HV-43-4B	1	1590	----	7	2-3/4	4	1-1/8	1-7/8	2-1/4	3/4	4.875
WFC2HV-43-6B	2			7-1/4	2-3/4	6	1-1/8	1-7/8	2-1/4	3/4	7.400
WFC2HV-46-4B	1	1700 - 1750	1510 - 1590	7-1/8	2-3/4	4	1-1/8	2-1/4	3	1	7.125
WFC2HV-46-6B	2			7-1/8	2-5/8	6	1-1/8	2-1/16	3	13/16	5.500
WFC2HV-49-4B	1	2000	1780 - 2034	7-1/4	2-3/4	4	1-1/8	2-1/4	3	1-1/8	6.825
WFC2HV-49-6B	2			7-1/8	2-5/8	6	1-1/8	2-1/16	3	13/16	7.500
WFC2HV-50-4B	1	2303	2156 - 2167	7-1/8	2-3/4	4	1-1/8	2-1/4	3	1	6.125
WFC2HV-50-6B	2			7-1/8	2-3/4	6	1-1/8	2-1/4	3	1	8.800
WFC2HV-52-4B	1	2500	2312	7-1/4	2-3/4	4	1-1/8	2-3/16	3	1-1/16	8.625
WFC2HV-52-6B	2			7-1/4	2-3/4	6	1-1/8	2-1/4	3	1	9.000
WFC2HV-53-4B	1	2750	2515	7-1/4	2-3/4	4	1-1/8	2-3/16	3	1-1/16	8.625
WFC2HV-53-6B	2			7-1/4	2-3/4	6	1-1/8	2-1/4	3	1	9.000

EHV TERMINALS

TYPE WFC3HV

Weldment

Three Cables to Flat

Casting Alloy: 356-T6 Aluminum
Options: See Page 140

ALUMINUM • 345 - 500kV

Designed for corona-free service at 345 and 500kV, either singly or paired back-to-back as noted. Pads are finished both sides. One hardware shield is furnished as part of the catalog number. Where an additional shield is required, add suffix (HS) to catalog number. For 90° pad angle, add (90) to the catalog number.

Example: WFC3HV90-52-4B-HS.

Note: See hardware shield AA-1094 or HS-6B.

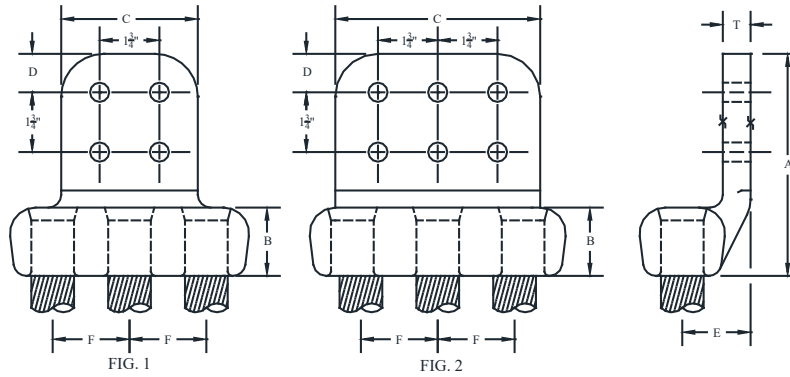

CATALOG NUMBER	FIG NO	CONDUCTOR RANGE		DIMENSIONS - INCHES							WEIGHT (POUNDS)
		AAC	ACSR	A	B	C	D	E	F	T	
WFC3HV-36-4B	1	1000 - 1113 MCM	900 - 1033 MCM	6-1/2	2	4	1-1/8	2	2-1/2	7/8	5.425
WFC3HV-36-6B	2			6-1/2	2	6	1-1/8	2	2-1/2	7/8	6.750
WFC3HV-37-4B	1	1113 - 1272 MCM	1033 - 1192 (45/7) MCM	6-1/2	2	4	1-1/8	2	2-1/2	7/8	5.425
WFC3HV-37-6B	2			6-1/2	2	6	1-1/8	2	2-1/2	7/8	6.750
WFC3HV-39-4B	1	1250 - 1351 MCM	1113 - 1192 MCM	6-7/8	2-3/8	4	1-1/8	2-1/8	2-1/8	1	6.125
WFC3HV-39-6B	2			6-7/8	2-3/8	6	1-1/8	2-1/8	2-1/8	7/8	5.750
WFC3HV-41-4B	1	1250 - 1510 MCM	1192 - 1272 MCM	6-7/8	2-3/8	4	1-1/8	2-1/8	2-1/8	1	6.125
WFC3HV-41-6B	2			6-7/8	2-3/8	6	1-1/8	2-1/8	2-1/8	7/8	7.000
WFC3HV-43-4B	1	1590 MCM	1272 MCM	7-1/8	2-1/2	4	1-1/8	2	2	1	5.725
WFC3HV-43-6B	2			7	2-5/8	6	1-1/8	2	2	3/4	7.500
WFC3HV-46-4B	1	1750 MCM	1590 MCM	7-1/8	2-3/4	4	1-1/8	2-7/16	2-1/4	1-1/4	8.125
WFC3HV-46-6B	2			7-1/8	2-3/4	6	1-1/8	2-1/16	2-1/4	1	9.000
WFC3HV-49-4B	1	2000 MCM	1780 - 2034 MCM	7-1/8	2-3/4	4	1-1/8	2-7/16	2-1/4	1-1/4	8.125
WFC3HV-49-6B	2			7-1/8	2-3/4	6	1-1/8	2-1/16	2-1/4	1	9.000
WFC3HV-51-4B	1	2250 - 2303 MCM	2156 MCM	7-1/8	2-3/4	4	1-1/8	3-1/8	3	1-1/4	9.300
WFC3HV-51-6B	2			7-1/8	2-3/4	6	1-1/8	2-1/16	2-1/4	1	11.300
WFC3HV-52-4B	1	2500 MCM	2312 MCM	7-1/8	2-3/4	4	1-1/8	3-1/8	3	1-1/4	9.300
WFC3HV-52-6B	2			7-1/8	2-3/4	6	1-1/8	3-1/8	3	1-1/4	11.300
WFC3HV-56-4B	1	3500 MCM	----	7-1/2	3	4	1-1/8	3	3	1-1/4	9.300
WFC3HV-56-6B	2			7-1/2	3	6	1-1/8	3	3	1-1/4	11.300

EHV TERMINALS

TYPE WFCCV

Weldment Expansion
Pipe To Flat Pad

Self-shielding at voltages through 345kV by the flexible elements which serve as corona rings. Normally furnished without hardware shields. The 4-inch allowable movement accommodates 130 feet of aluminum bus over a 200°F temperature range.

Note: See hardware shield AA-1094.

Casting Alloy: 356-T6 Aluminum

Flexible Elements: Class A Stranded Cable

Options: See Page 140

ALUMINUM • 345 - 500kV

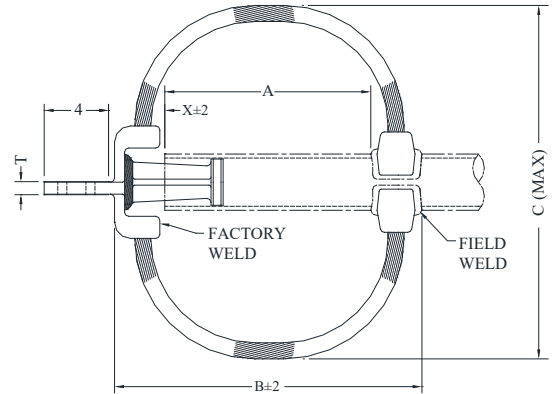
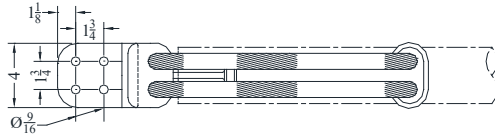

CATALOG NUMBER	PIPE SIZE		NO. CABLES	CURRENT CAPACITY	DIMENSION - INCHES					WEIGHT (POUNDS)
	(NPS)	(SCH 80)			A	B	C	T	X	
WFCCV-58-4B	2	-----	4	2000 A	12	17-1/2	24	3/4	3-1/2	13.10
WFCCV-58H-4B	-----	2	4	2000 A	12	17-1/2	24	3/4	3-1/2	13.10
WFCCV-60-4B	2-1/2	-----	4	2000 A	12	17-1/2	25	3/4	3-1/2	15.10
WFCCV-60H-4B	-----	2-1/2	4	2000 A	12	17-1/2	25	3/4	3-1/2	15.10
WFCCV-62-4B	3	-----	4	2400 A	12	17-1/2	25	3/4	3-1/2	14.80
WFCCV-62H-4B	-----	3	4	2400 A	12	17-1/2	25	3/4	3-1/2	14.80
WFCCV-63-4B	3-1/2	-----	4	2700 A	12-1/2	18-1/2	24	1	4	18.50
WFCCV-63H-4B	-----	3-1/2	4	2700 A	12-1/2	18-1/2	24	1	4	18.50
WFCCV-64-4B	4	-----	4	2700 A	12-1/2	19-1/8	24	1	3-7/8	18.75
WFCCV-64H-4B	-----	4	4	2700 A	12-1/2	19-1/8	24	1	3-7/8	18.75
WFCCV-67-4B	5	-----	6	3000 A	18-1/2	24-1/2	32	1-1/8	4	31.40
WFCCV-67H-4B	-----	5	6	3000 A	18-1/2	24-1/2	32	1-1/8	4	31.40
WFCCV-69-4B	6	-----	6	3000 A	21-1/8	27	33	1-1/8	4	33.70
WFCCV-69H-4B	-----	6	6	3000 A	21-1/8	27	33	1-1/8	4	33.70

TYPE WFCCH

Weldment Expansion
Pipe To Flat

Type WFCCH is identical to the type WFCCV above, except that the center-formed pad is rotated 90 degrees to place the flexible elements in the same plane as the pad surface. To specify, substitute WFCCH in the table above.

Casting Alloy: 356-T6 Aluminum

Flexible Elements: Class A Stranded Cable

Options: See Page 140

ALUMINUM • 345 - 500kV

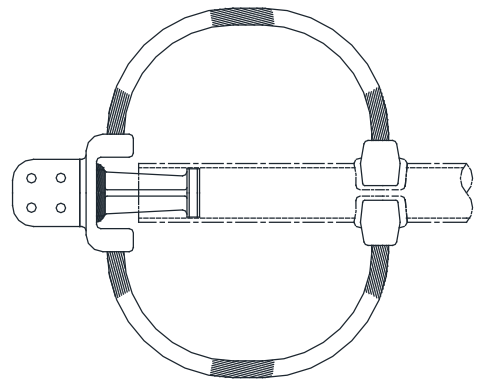

EHV TERMINALS

TYPE WFXTC-V-CS

Weldment Expansion
Pipe to Flat Pad

Casting Alloy: 356-T6 Aluminum
Laminated Straps: 1100-0 Aluminum
Shield Rings: 6063-T6 Aluminum
Options: See Page 140

ALUMINUM • 345 - 500kV

Aluminum weldment expansion terminal for Aluminum pipe to flat pads. Designed for corona-free service at 345 & 500kV. The 4-inch allowable movement accommodates 130 feet of aluminum bus over a 200° F temperature range. For pad extension, add suffix (E) to catalog number. SPECIFY: CS1 for 345kV or CS2 for 500kV.

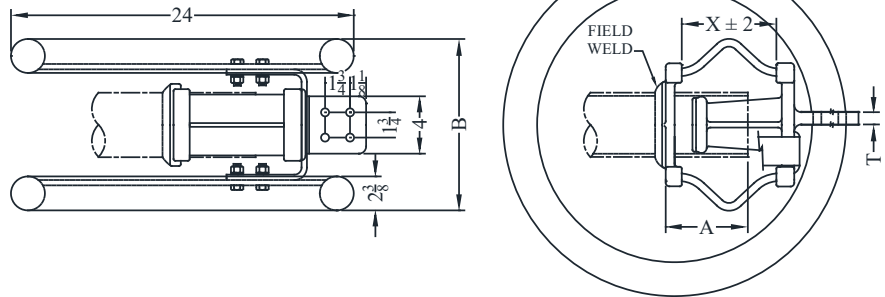

CATALOG NUMBER	PIPE SIZE		CURRENT CAPACITY	DIMENSION - INCHES				WEIGHT (POUNDS)
	(NPS)	(SCH 80)		A	B	T	X	
WFXTC-V-63-4B	3-1/2	----	2535A	6	12	7/8	6-1/2	12.40
WFXTC-V-63H-4B	----	3-1/2	2535A	6	12	7/8	6-1/2	12.40
WFXTC-V-64-4B	4	----	3000A	6	12	7/8	6-1/2	15.10
WFXTC-V-64H-4B	----	4	3000A	6	12	7/8	6-1/2	15.10
WFXTC-V-67-4B	5	----	3700A	7-3/8	14-1/2	1-1/8	8	22.00
WFXTC-V-67H-4B	----	5	3700A	7-3/8	14-1/2	1-1/8	8	22.00
WFXTC-V-69-4B	6	----	4500A	7-3/8	14-1/2	1-1/8	8	28.50
WFXTC-V-69H-4B	----	6	4500A	7-3/8	14-1/2	1-1/8	8	28.50

* CONTACT FACTORY FOR OTHER CONDUCTOR COMBINATIONS

TYPE WFRTC-V

Weldment Pipe to Flat
Expansion - Roller Guide

Casting Alloy: 356-T6 Aluminum
Laminated Straps: 1100-0 Aluminum
Shield Rings: 6063-T6 Aluminum
Options: See Page 140

ALUMINUM • 345 - 500kV

Designed for corona-free service at 500kV. The roller guide allows friction-free movement of the pipe, eliminating the possibility of misalignment of switch-gear contacts due to insulator deflection. The 4-inch allowable movement accommodates 130 feet of aluminum bus over a 200° F temperature range. For pad extension, add suffix (E) to catalog number.

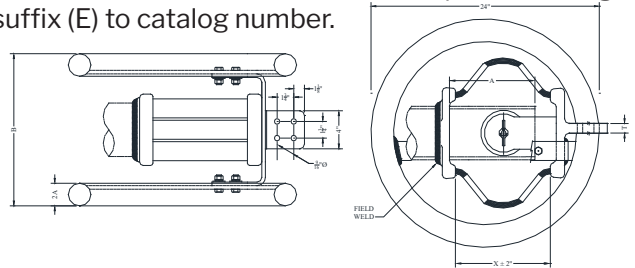

CATALOG NUMBER	PIPE SIZE		CURRENT CAPACITY	DIMENSION - INCHES				WEIGHT (POUNDS)
	(NPS)	(SCH 80)		A	B	T	X	
WFRTC-V-63-4B	3-1/2	----	2535A	9-1/8	12	3/4	10	26.00
WFRTC-V-63H-4B	----	3-1/2	2535A	9-1/8	12	3/4	10	26.00
WFRTC-V-64-4B	4	----	3000A	9-1/8	12	1	10	37.10
WFRTC-V-64H-4B	----	4	3000A	9-1/8	12	1	10	37.10
WFRTC-V-67-4B	5	----	3700A	10	14-1/2	1-1/8	12	43.40
WFRTC-V-67H-4B	----	5	3700A	10	14-1/2	1-1/8	12	43.40
WFRTC-V-69-4B	6	----	4500A	10	14-1/2	1-1/8	12	40.00
WFRTC-V-69H-4B	----	6	4500A	10	14-1/2	1-1/8	12	40.00

EHV TERMINALS

TYPE WFTCHV

Weldment
Pipe To Flat Pad

Casting Alloy: 356-T6 Aluminum
Options: See Page 140

ALUMINUM • 345 - 500kV

Designed for corona-free service at 345kV and 500kV as indicated. Normally furnished without hardware shield. When hardware shield is required, add suffix (HS) to catalog number. Example: WFTCHV-63-4B-HS. Note: See hardware shield AA-1094.

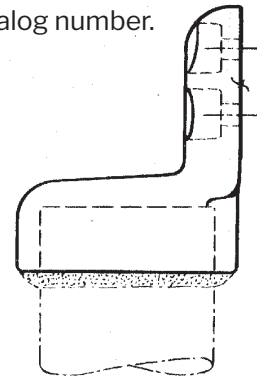
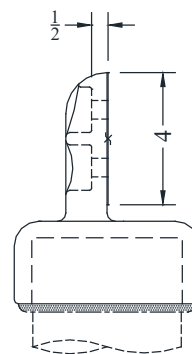
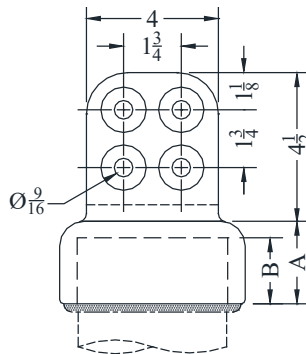

WFTHV
Offset pad type

CATALOG NUMBER	PIPE SIZE (NPS)	MAX KV	DIMENSIONS - INCHES		WEIGHT (POUNDS)
			A	B	
WFTCHV-58-4B	2	345	1-7/8	1-1/2	3.00
WFTCHV-60-4B	2-1/2	345	2	1-1/2	2.75
WFTCHV-62-4B	3	500	2-1/4	1-3/4	3.25
WFTCHV-63-4B	3-1/2	500	2-5/16	1-7/8	3.50
WFTCHV-64-4B	4	500	2-1/2	2	4.50
WFTCHV-67-4B	5	500	3-1/2	2-3/4	7.25
WFTCHV-69-4B	6	500	3-1/2	2-3/4	8.50

TYPE WFTD

Weldment Bifurcating
Pipe To Flat

Casting Alloy: 356-T6 Aluminum
Pad Mounting Hardware: Aluminum Alloy
Options: See Page 140

ALUMINUM • 345 - 500kV

Type WFTD is designed for corona-free service at voltage levels shown, when used with two EHV compression terminals to form a Bifurcating pipe to cable joint.

Note: (2) AA-1094 hardware shields are furnished with this catalog number.

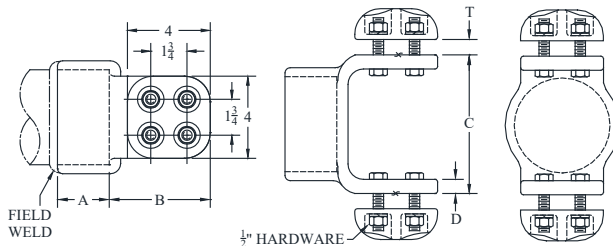

CATALOG NUMBER	PIPE SIZE (NPS)	MAX KV	DIMENSIONS - INCHES					WEIGHT (POUNDS)
			A	B	C	D	T	
WFTD-58-4B	2	345	1-1/2	4-3/4	5	5/8	3/4	7.30
WFTD-60-4B	2-1/2	345	1-1/2	4-3/4	5	5/8	3/4	7.30
WFTD-62-4B	3	500	1-3/4	4-7/8	5-3/8	3/4	7/8	7.80
WFTD-63-4B	3-1/2	500	1-7/8	4-7/8	6	3/4	7/8	7.75
WFTD-64-4B	4	500	2-1/2	4-7/8	6-3/4	11/16	7/8	7.50
WFTD-67-4B	5	500	2-5/8	5	7-1/2	7/8	1	11.30
WFTD-69-4B	6	500	2-3/4	5	8-1/8	7/8	1	14.10

EHV TERMINALS

TYPE WFTICHV

Internal Weldment
Pipe to Flat Pad

Designed for corona-free service at 345kV and 500kV as indicated.
Catalog numbers listed below do not include hardware shields.
When hardware shields are required, add suffix (HS) to catalog number.
Example: WFTICHV-60-4B-HS
Note: See hardware shield AA-1094.

Casting Alloy: 356-T6 Aluminum
Options: See Page 140

ALUMINUM • 345 - 500kV

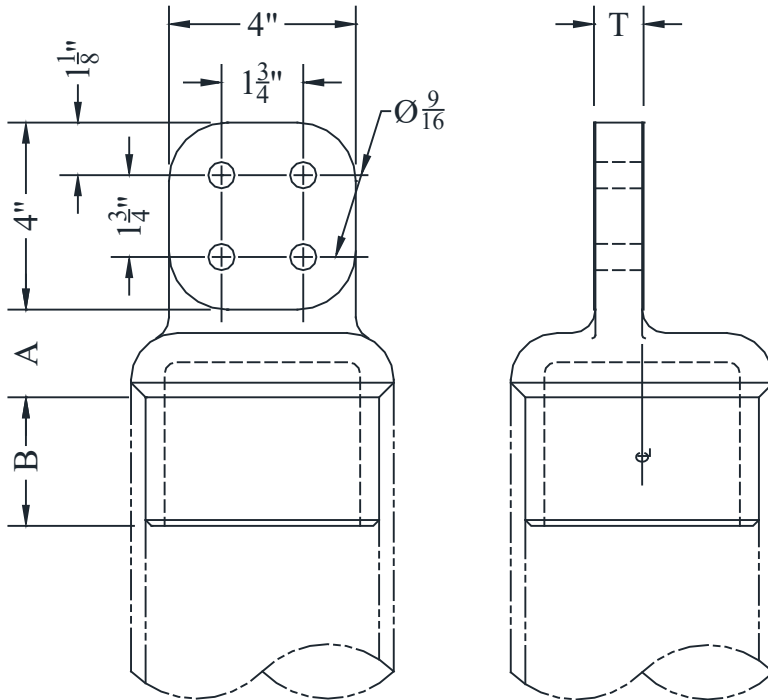

CATALOG NUMBER	PIPE SIZE		MAX KV	DIMENSION - INCHES			WEIGHT (POUNDS)
	(NPS)	(SCH 80)		A	B	T	
WFTICHV-58-4B	2	-----	345	1-1/2	1-1/2	1/2	2.00
WFTICHV-58H-4B	-----	2	345	1-1/2	1-1/2	1/2	2.00
WFTICHV-60-4B	2-1/2	-----	345	1-1/2	2	5/8	1.75
WFTICHV-60H-4B	-----	2-1/2	345	1-1/2	2	5/8	1.75
WFTICHV-62-4B	3	-----	500	1-3/4	2	5/8	2.25
WFTICHV-62H-4B	-----	3	500	1-3/4	2	5/8	2.25
WFTICHV-63-4B	3-1/2	-----	500	1-3/4	2	3/4	3.00
WFTICHV-63H-4B	-----	3-1/2	500	1-3/4	2	3/4	3.00
WFTICHV-64-4B	4	-----	500	1-3/4	2	7/8	3.25
WFTICHV-64H-4B	-----	4	500	1-3/4	2	7/8	3.25
WFTICHV-67-4B	5	-----	500	1-7/8	2-3/4	1	5.25
WFTICHV-67H-4B	-----	5	500	1-7/8	3-3/4	1	5.25
WFTICHV-69-4B	6	-----	500	2	3	1-1/8	6.50
WFTICHV-69H-4B	-----	6	500	2	3	1-1/8	6.50

EHV TERMINALS

TYPE WHV-FXT

Weldment Expansion
Pipe To Flat Pad

Casting Alloy: 356-T6 Aluminum
Laminated Straps: 1100-0 Aluminum
Options: See Page 140

Designed for corona-free service at 500kV . The compact design reduces interference problems with shield rings on EHV switch gear, while allowing 2-inch linear movement of the pipe conductor. Two hardware shields are provided, except when extension pad is specified by addition of suffix (E) to the catalog number.

EXAMPLE: WHV-FXT-64-4F-E.

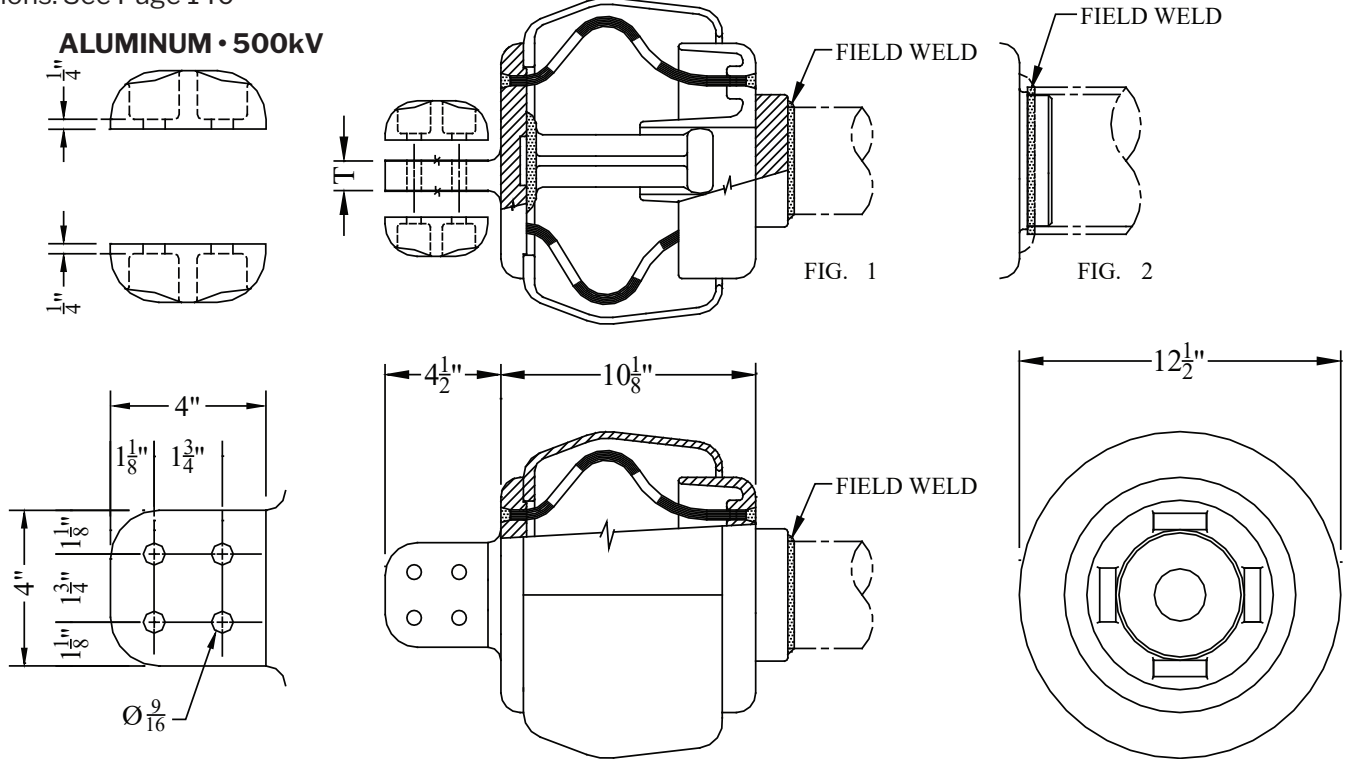

CATALOG NUMBER	PIPE SIZE (NPS)		FIG. NO.	CURRENT CAPACITY	T	WEIGHT (POUNDS)
	SCH 40	SCH 80				
WHV-FXT-58-4F	2	----	1	2000	7/8	30.40
WHV-FXT-58H-4F	----	2	1	2000	7/8	30.40
WHV-FXT-60-4F	2-1/2	----	1	2000	7/8	26.65
WHV-FXT-60H-4F	----	2-1/2	1	2000	7/8	26.65
WHV-FXT-62-4F	3	----	1	2400	7/8	27.00
WHV-FXT-62H-4F	----	3	1	2400	7/8	27.00
WHV-FXT-63-4F	3-1/2	----	1	2400	1-1/8	28.95
WHV-FXT-63H-4F	----	3-1/2	1	2400	1-1/8	28.95
WHV-FXT-64-4F	4	----	2	3000	1-1/8	31.75
WHV-FXT-64H-4F	----	4	2	3000	1-1/8	31.75
WHV-FXT-67-4F	5	----	2	3000	1-1/8	31.75
WHV-FXT-67H-4F	----	5	2	3000	1-1/8	31.75
WHV-FXT-69-4F	6	----	2	3000	1-1/8	32.50
WHV-FXT-69H-4F	----	6	2	3000	1-1/8	32.50

ALUMINUM, BRONZE & EHV COUPLERS



ASCT



ALB45



ALB90

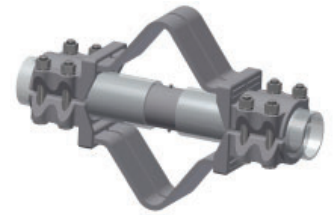

AXCF



ACTC



ACCC



WSC/WSCL



WSCR

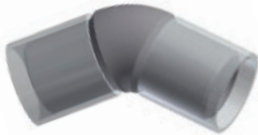

WLBI45



WLBI90



WLBUA



WXCF



CCT



LB45



LB90



CXT



ETRCT



ACCC-BR



TXR



ASCTHV



WSC

WSR



WBCHV



WLBI-HV



WFTD



WSTC3



WETC2



WXCCF



WXCF-CS

ALUMINUM COUPLERS

TYPE ACCC

Straight Bolted
Cable Main to Cable Tap

Aluminum alloy straight coupler for aluminum cable to cable connections. Clamping bolts have hex-stops for one wrench installation. Contact sealant is recommended.
* ACCC-1139-1139 has reversible caps for a wide range of cable.

Casting Alloy: 356-T6 Aluminum
Clamping Hardware: Aluminum Alloy

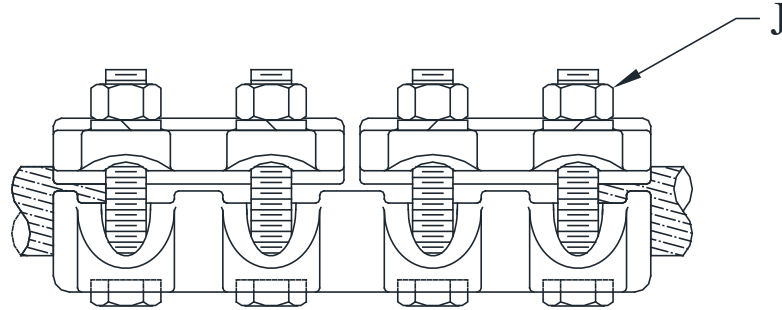
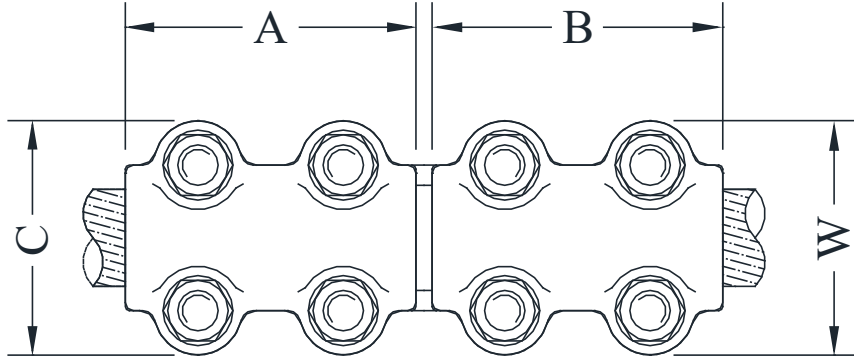

CATALOG NUMBER	CONDUCTOR RANGE		DIMENSIONS - INCHES					WEIGHT (POUNDS)
	AAC	ACSR	A	B	W	C	J	
ACCC-1313	#4 - 266 MCM	#4 - 4/0 MCM	3	3	2-3/8	2-3/8	1/2	1.55
ACCC-2020	246.9 - 500 MCM	4/0 - 397 MCM	3-1/2	3-1/2	2-1/2	2-1/2	1/2	1.10
ACCC-2424	350 - 650 MCM	336-556 MCM	4	4	2-7/8	2-7/8	1/2	3.60
ACCC-3434	550 - 1000 MCM	477 - 795 MCM	4	4	3	3	1/2	1.40
ACCC-3939	874.5 - 1272 MCM	715 - 1113 MCM	4-1/4	4-1/4	3-1/4	3-1/4	1/2	3.45
ACCC-4343	1250 - 1590 MCM	1113 - 1431 MCM	4-1/2	4-1/2	3-5/8	3-5/8	5/8	6.00
ACCC-4949	1500 - 2000 MCM	1272 - 1780 MCM	4-3/4	4-3/4	3-7/8	3-7/8	5/8	5.70
*ACCC-1139-1139	4/0 - 1272 MCM	4/0 - 1192 MCM	4-1/4	4-1/4	3-1/4	3-1/4	1/2	4.00

ALUMINUM COUPLERS

TYPE ACTC

Straight Bolted
Pipe Main to Cable Tap

Aluminum alloy straight coupler for aluminum pipe to cable connections. Clamping bolts have hex-stops for one wrench installation. Contact sealant is recommended.

Casting Alloy: 356-T6 Aluminum
Clamping Hardware: Aluminum Alloy

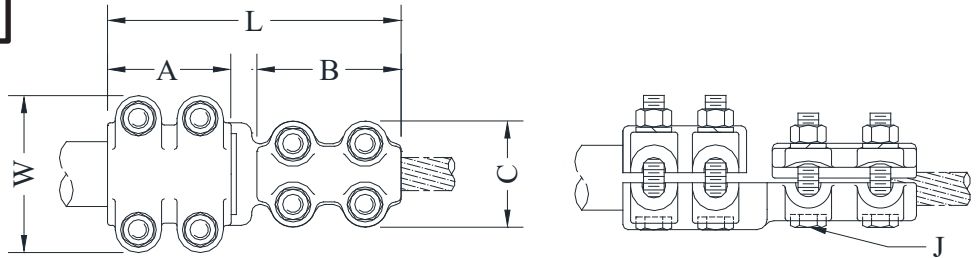

CATALOG NUMBER	CONDUCTOR RANGE			DIMENSIONS - INCHES						WEIGHT (POUNDS)
	PIPE MAIN (NPS)	CABLE TAP		L	A	B	W	C	J	
		AAC	ACSR							
ACTC-3013	3/4	#4 - 266 MCM	#4 - 4/0 MCM	5-7/8	2-3/8	3	2-7/8	2-3/8	1/2	1.80
ACTC-3913	1	#4 - 266 MCM	#4 - 4/0 MCM	6-1/2	3	3	3-1/8	2-3/8	1/2	1.85
ACTC-3920		4/0 - 500 MCM	4/0 - 397.5 MCM	7-1/8	3	3-1/2	3-1/8	2-5/8	1/2	3.15
ACTC-4913	1-1/4	#4 - 266 MCM	#4 - 4/0 MCM	6-1/2	3	3	3-5/8	2-3/8	1/2	3.35
ACTC-4920		4/0 - 500 MCM	4/0 - 397.5 MCM	6-13/16	2-3/4	3-1/2	3-5/8	2-5/8	1/2	2.30
ACTC-4924		350 - 650 MCM	336 - 556 MCM	7-3/16	2-7/16	4	3-7/8	2-7/8	1/2	3.90
ACTC-5320	1-1/2	4/0 - 500 MCM	4/0 - 397.5 MCM	7-1/8	3	3-1/2	3-7/8	2-5/8	1/2	2.90
ACTC-5324		350 - 650 MCM	336 - 556 MCM	7-9/16	3-1/8	4	3-7/8	2-7/8	1/2	3.15
ACTC-5820	2	4/0 - 500 MCM	4/0 - 397.5 MCM	7-5/8	3-1/2	3-1/2	4-3/8	2-5/8	1/2	3.35
ACTC-5824		350 - 650 MCM	336 - 556 MCM	8	3-1/2	4	4-3/8	2-7/8	1/2	3.10
ACTC-5834		550 - 1000 MCM	447-795 MCM	8-1/8	3-1/2	4	4-3/8	3	1/2	3.35
ACTC-6020	2-1/2	4/0 - 500 MCM	4/0 - 397.5 MCM	7-5/8	3-1/2	3-1/2	4-3/4	2-5/8	1/2	3.65
ACTC-6024		350 - 650 MCM	336 - 556 MCM	7-7/8	3-1/2	4	4-3/4	2-7/8	1/2	3.65
ACTC-6034		550 - 1000 MCM	477 - 795 MCM	8-1/8	3-1/2	4	4-3/4	3	1/2	3.90
ACTC-621139	3	#4/0 - 1272 MCM	#4/0 - 1192 (45/7) MCM	8-1/2	3-1/2	4-1/4	5-3/8	3-1/4	1/2	6.05
ACTC-6234		550 - 1000 MCM	477 - 795 MCM	7-15/16	3-1/2	4	5-3/8	3	1/2	5.00
ACTC-6239		874 - 1250 MCM	715 - 1113 MCM	8-1/2	3-1/2	4-1/4	5-3/8	3-1/4	1/2	5.80
ACTC-6243		1250 - 1590 MCM	1113 - 1431 MCM	9-1/4	4	4-1/2	5-3/4	3-5/8	5/8	7.10
ACTC-6334	3-1/2	550 - 1000 MCM	477 - 795 MCM	7-3/4	3-1/4	4	5-7/8	3	1/2	5.25
ACTC-6339		874-1300 MCM	715 - 1113 MCM	8-1/4	3-1/4	4-1/4	5-7/8	3-1/4	1/2	6.80
ACTC-6343		1250 - 1590 MCM	1113 - 1431 MCM	9-5/8	4-3/8	4-1/2	6-1/4	3-5/8	5/8	7.90
ACTC-641139	4	#4/0 - 1272 MCM	#4/0 - 1192 MCM	8-1/4	3-1/4	4-1/4	6-3/8	3-1/4	1/2	6.05
ACTC-6434		550 - 1000 MCM	477 - 795 MCM	7-7/8	3-1/4	4	6-3/8	3	1/2	5.50
ACTC-6439		874 - 1300 MCM	715 - 1113 MCM	8-1/4	3-1/4	4-1/4	6-3/8	3-1/4	1/2	5.80
ACTC-6443		1272 - 1590 MCM	1192 - 1431 MCM	9-5/8	4-1/2	4-1/2	6-3/4	3-5/8	5/8	9.10

ALUMINUM COUPLERS

TYPE ALB45

45° Angle Bolted
Pipe Main to Pipe Tap

Aluminum alloy angle coupler for aluminum pipe connections at 45°. Clamping bolts have hex-stops for one wrench installation. Contact sealant is recommended.

Casting Alloy: 356-T6 Aluminum
Clamping Hardware: Aluminum Alloy

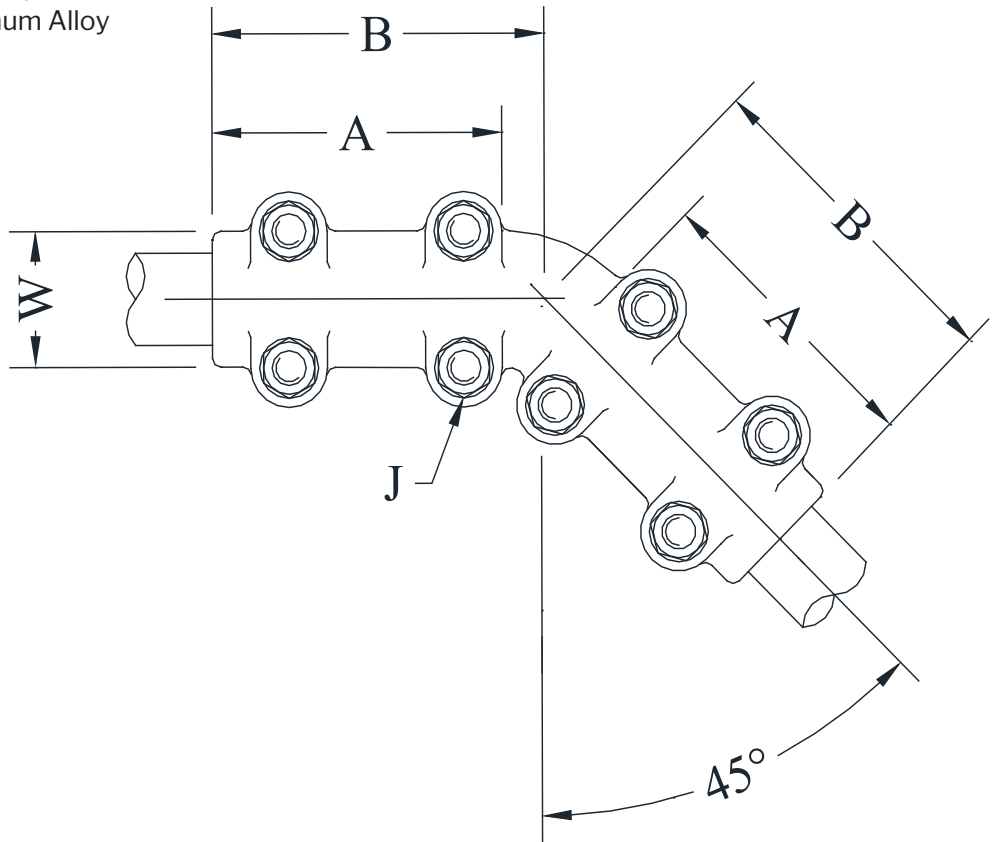

CATALOG NUMBER	CONDUCTOR SIZE (NPS)		DIMENSIONS - INCHES				WEIGHT (POUNDS)
	PIPE MAIN	PIPE TAP	A	B	W	J	
ALB45-3030	3/4	3/4	2-1/2	3-1/16	2-7/8	1/2	2.10
ALB45-3939	1	1	4-1/4	4-7/8	1-15/16	1/2	2.60
ALB45-4949	1-1/4	1-1/4	3	3-9/16	3-5/8	1/2	3.60
ALB45-5353	1-1/2	1-1/2	3-7/8	4-7/16	2-11/16	1/2	3.70
ALB45-5858	2	2	3-1/2	4-9/16	3-1/8	1/2	5.20
ALB45-6060	2-1/2	2-1/2	4-11/16	6-15/32	3-11/16	1/2	7.30
ALB45-6262	3	3	4	5-3/16	4-1/2	5/8	8.30
ALB45-6363	3-1/2	3-1/2	4-3/8	5-7/8	5-7/32	5/8	12.00
ALB45-6464	4	4	4-15/16	6-27/32	5-13/16	5/8	9.50
ALB45-6767	5	5	6-3/16	8-3/4	7	5/8	36.15

* Consult manufacturer for further details or unlisted applications.

ALUMINUM COUPLERS

TYPE ALB90

90° Angle Bolted

Pipe Main to Pipe Tap

Aluminum alloy angle coupler for aluminum pipe connections at 90°.
Clamping bolts have hex-stops for one wrench installation.
Contact sealant is recommended.

Casting Alloy: 356-T6 Aluminum
Clamping Hardware: Aluminum Alloy

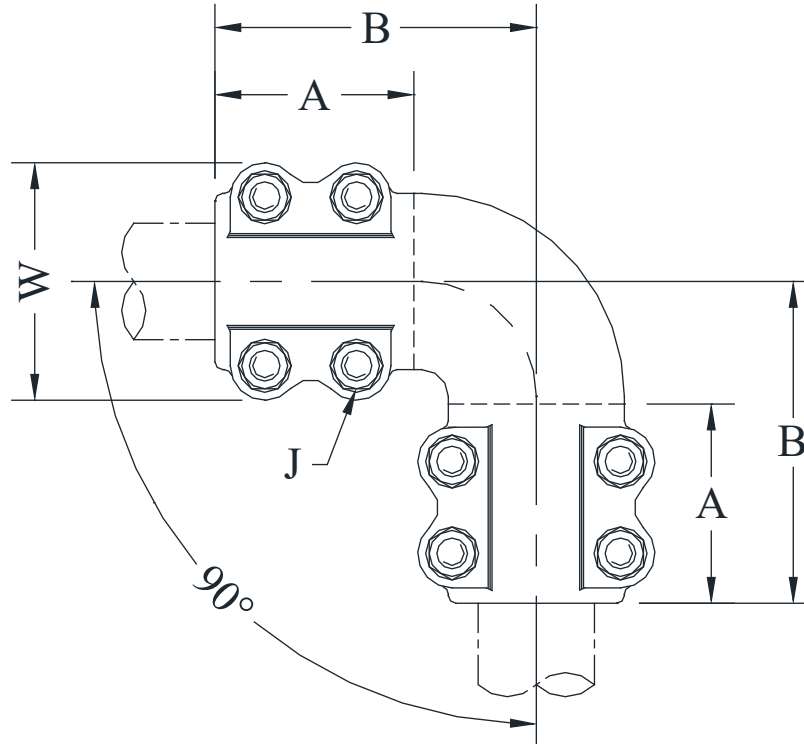

CATALOG NUMBER	CONDUCTOR SIZE (NPS)		DIMENSIONS - INCHES				WEIGHT (POUNDS)
	PIPE MAIN	PIPE TAP	A	B	W	J	
ALB90-3030	3/4	3/4	2-1/2	3-15/16	3	1/2	1.80
ALB90-3939	1	1	2-3/4	4-7/8	3-1/4	1/2	2.20
ALB90-4949	1-1/4	1-1/4	3	4-3/4	3-5/8	1/2	3.60
ALB90-5353	1-1/2	1-1/2	3-5/16	5	3-7/8	1/2	4.50
ALB90-5858	2	2	3-9/16	5-1/2	4-3/8	1/2	5.60
ALB90-6060	2-1/2	2-1/2	3-5/8	6-1/4	4-3/4	1/2	8.40
ALB90-6262	3	3	4-1/8	6-3/8	5-7/8	5/8	10.70
ALB90-6363	3-1/2	3-1/2	4-3/8	6-7/8	6-3/8	5/8	12.00
ALB90-6464	4	4	4-1/4	7-15/16	7	5/8	16.00
ALB90-6767	5	5	7	11-1/4	7-7/8	5/8	37.15

ALUMINUM COUPLERS

TYPE ALB-V

Bolted Variable Angle Coupler
Pipe To Pipe

Aluminum alloy bolted variable angle coupler for connecting two aluminum pipes at field set angles.
Contact surfaces are finished and coated with a sealant prior to packaging for shipment.

Casting Alloy: 356-T6 Aluminum
Clamping Hardware: Aluminum Alloy

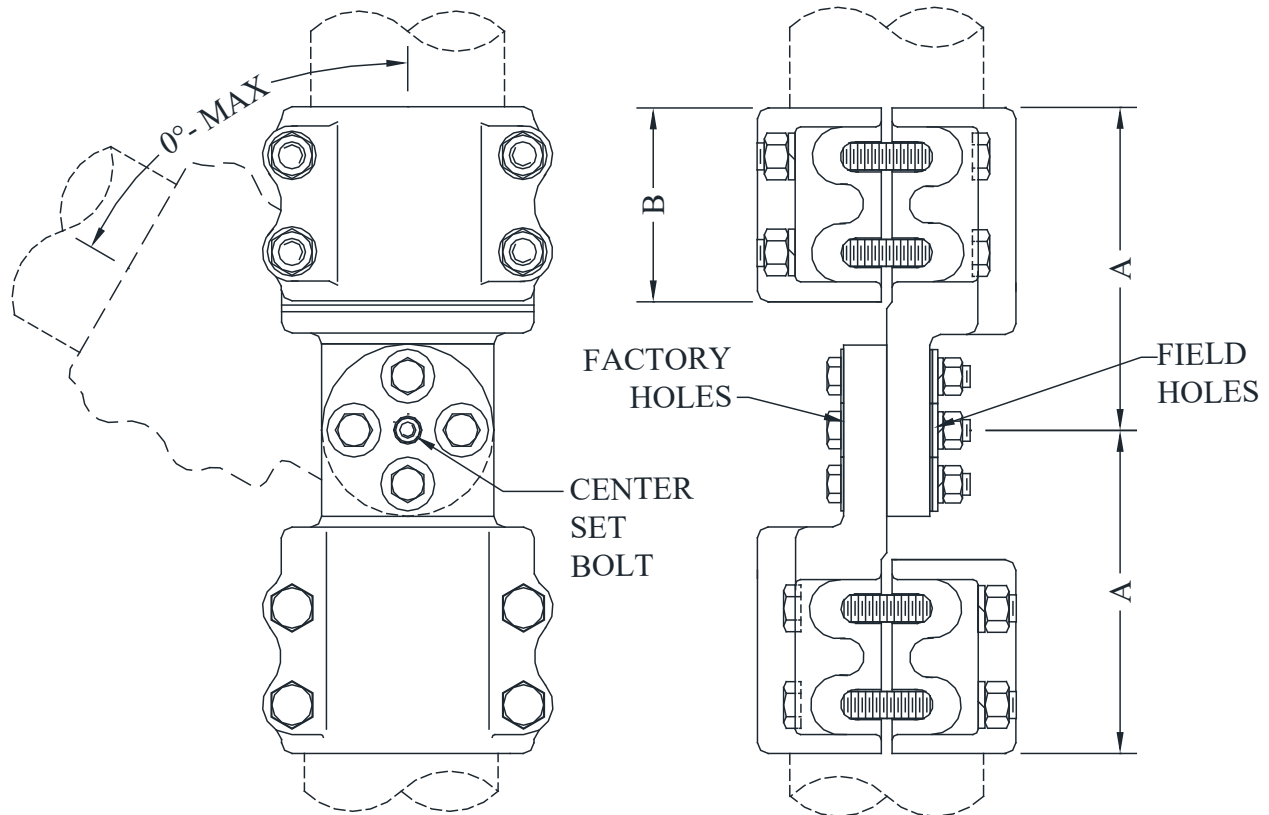

CATALOG NUMBER	PIPE SIZE (NPS)	MAX ANGLE	DIMENSION-INCHES		WEIGHT (POUNDS)
			A	B	
ALB-V-3030	3/4	90	5	2-3/8	4.20
ALB-V-3939	1	90	5	3	4.90
ALB-V-4949	1-1/4	90	5-7/16	3	5.30
ALB-V-5353	1-1/2	90	5-1/4	3-1/8	6.60
ALB-V-5858	2	90	6-1/8	3-1/2	6.80
ALB-V-6060	2-1/2	90	6-5/16	3-1/2	7.30
ALB-V-6262	3	90	6-7/8	4	13.10
ALB-V-6363	3-1/2	90	6-7/8	4-3/8	15.60
ALB-V-6464	4	90	7-1/2	4-1/2	17.60
ALB-V-6767*	5	85	10-1/8	6-3/4	31.20
ALB-V-6969*	6	75	10-3/8	7	33.00

*SIX CLAMPING BOLTS PER CAP



ALUMINUM COUPLERS

TYPE ASCT

Straight Bolted
Pipe Main to Pipe Tap

Aluminum alloy straight coupler for aluminum to aluminum pipe connections. Clamping bolts have hex-stops for one-wrench installation. Contact sealant is recommended.

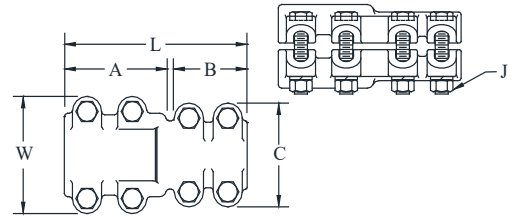

Casting Alloy: 356-T6 Aluminum
Clamping Hardware: Aluminum Alloy

CATALOG NUMBER	CONDUCTOR SIZE (NPS)		DIMENSIONS - INCHES						WEIGHT (POUNDS)
	PIPE MAIN	PIPE TAP	L	A	B	W	C	J	
ASCT-3030	3/4	3/4	8	4	4	2-3/4	2-3/4	1/2	3.05
ASCT-3939	1	1	8-1/2	4-1/4	4-1/4	3-1/16	3-1/16	1/2	2.70
ASCT-4949	1-1/4	1-1/4	8-1/2	4-1/4	4-1/4	3-7/16	3-7/16	1/2	3.10
ASCT-5339	1-1/2	1	6-11/16	3-1/4	3-1/16	3-7/8	3-1/8	1/2	3.15
ASCT-5349		1-1/4	10-1/2	3-1/8	3	3-7/8	3-5/8	1/2	4.40
ASCT-5353		1-1/2	9	4-1/2	4-1/2	3-5/8	3-5/8	1/2	3.35
ASCT-5830	2	3/4	8-3/4	4-3/8	4-1/8	4-1/8	2-13/16	1/2	3.15
ASCT-5839		1	8-1/2	3-1/2	4-1/4	4-3/8	3-1/4	1/2	3.45
ASCT-5849		1-1/4	9	4-5/8	4-3/8	4-1/8	3-7/16	1/2	3.15
ASCT-5853		1-1/2	7-1/16	3-5/8	3-1/8	4-3/8	3-7/8	1/2	3.30
ASCT-5858		2	9-1/4	4-5/8	4-5/8	4-1/8	4-1/8	1/2	3.70
ASCT-6039	2-1/2	1	7-1/4	3-1/2	3	4-3/4	3-1/8	1/2	3.45
ASCT-6049		1-1/4	11	3-1/2	3	4-3/4	3-5/8	1/2	3.50
ASCT-6053		1-1/2	11	3-1/2	3-1/8	4-3/4	3-7/8	1/2	5.95
ASCT-6058		2	8	3-5/8	3-3/8	4-3/4	4-1/4	1/2	6.70
ASCT-6060		2-1/2	9	4-1/2	4-1/2	5-1/8	5-1/8	5/8	7.55
ASCT-6253	3	1-1/2	9-9/32	4-5/8	4-21/32	5-1/4	3-5/8	1/2	4.80
ASCT-6258		2	7-5/8	3-5/8	3-3/8	5-3/8	4-3/8	1/2	4.80
ASCT-6260		2-1/2	8-5/8	4	4	5-3/4	5-1/8	5/8	7.75
ASCT-6262		3	10-1/8	5-1/16	5-1/16	5-3/4	5-3/4	5/8	9.95
ASCT-6362	3-1/2	3	11	5-1/2	5-1/2	6-1/2	6-1/2	5/8	10.75
ASCT-6363		3-1/2	11	5-1/2	5-1/2	6-1/2	6-1/2	5/8	9.46
ASCT-6458	4	2	7-3/8	3-1/4	3-1/2	6-3/8	4-3/8	1/2	7.90
ASCT-6460		2-1/2	7-3/8	3-1/4	3-1/2	6-3/8	4-3/4	1/2	6.30
ASCT-6462		3	9-1/8	4-1/2	4-1/8	6-3/4	5-3/4	5/8	8.90
ASCT-6463		3-1/2	12	6	6	6-7/8	6-7/8	5/8	18.30
ASCT-6464		4	12	6	6	6-7/8	6-7/8	5/8	19.85
ASCT-6564	4-1/2	4	10-1/2	5-1/2	5	7-1/4	6-3/4	5/8	19.20
ASCT-6565		4-1/2	11-1/2	5-1/2	5-1/2	7-1/4	7-1/4	5/8	17.50
ASCT-6763	5	3-1/2	9-7/8	5	4-7/8	7-7/8	6-1/4	5/8	19.30
ASCT-6764		4	10-3/4	5	5-3/4	7-7/8	6-3/4	5/8	20.00
ASCT-6767		5	13-1/2	5-13/16	5-13/16	7-7/8	7-7/8	5/8	15.75
ASCT-6967	6	5	12-7/8	6-7/16	6-7/16	8-7/8	8-7/8	5/8	29.65
ASCT-6969		6	12-3/4	6-3/8	6-3/8	8-7/8	8-7/8	5/8	24.65

*Consult manufacturer for further details or unlisted applications.

ALUMINUM COUPLERS

TYPE AXCF

Bolted Expansion
Pipe Main to Pipe Tap

Casting Alloy: 356-T6 Aluminum
Clamping Hardware: Aluminum
Laminated Straps: 1100-0 Aluminum
Alignment Guide: 6061-T6 Aluminum

Aluminum alloy expansion coupler with alignment guide for aluminum pipe connections. Clamping bolts have hex-stops for one-wrench installation. Contact sealant is recommended. Add suffix (H) to catalog number for SCH 80 pipe. Example: AXCF-6060H
Add suffix (-NG) for no guide. Example: AXCF-6060-NG

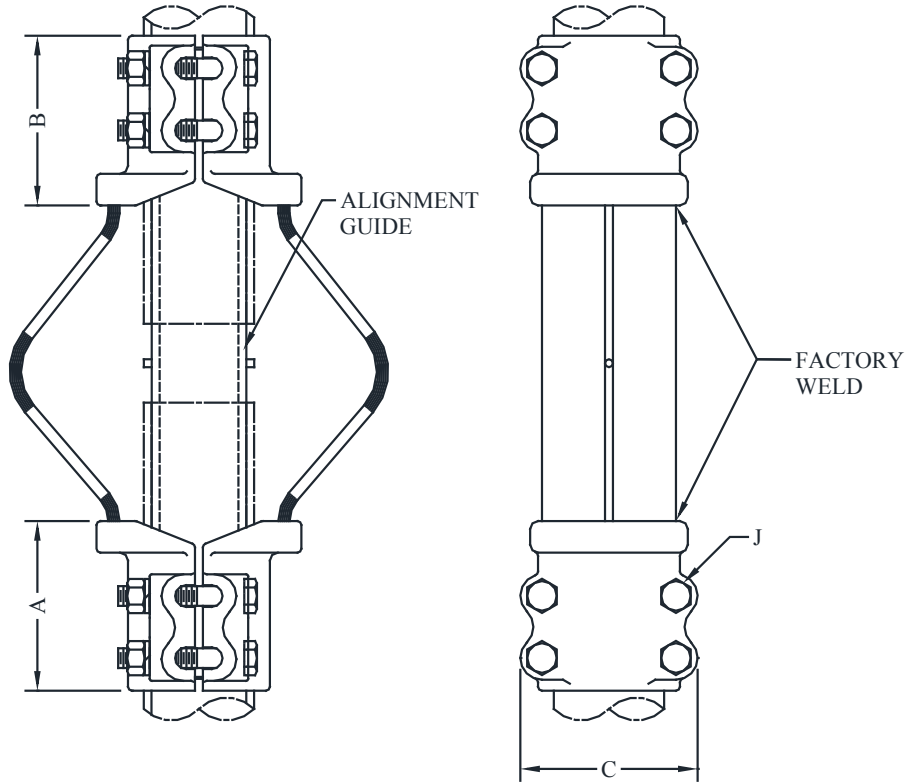

CATALOG NUMBER	CONDUCTOR SIZE (NPS)		DIMENSIONS - INCHES				WEIGHT (POUNDS)
	PIPE MAIN	PIPE TAP	A	B	C	J	
AXCF-3939	1	1	4	4	3-1/8	1/2	3.10
AXCF-4949	1-1/4	1-1/4	4-3/16	4-3/16	3-5/8	1/2	4.00
AXCF-5353	1-1/2	1-1/2	4-3/8	4-3/8	3-7/8	1/2	9.00
AXCF-5858	2	2	4-3/4	4-3/4	4-1/4	1/2	11.00
AXCF-6060	2-1/2	2-1/2	4-3/4	4-3/4	4-3/4	1/2	12.00
AXCF-6262	3	3	5-3/8	5-3/8	5-3/4	5/8	16.00
AXCF-6363	3-1/2	3-1/2	5-3/4	5-3/4	6-1/4	5/8	21.00
AXCF-6464	4	4	5-3/4	5-3/4	6-3/4	5/8	24.00
AXCF-6767	5	5	8-1/2	8-1/2	7-7/8	5/8	29.00

ALUMINUM COUPLERS

TYPE WLBI45 & 90

Angle Welded
Pipe Main to Pipe Tap

Aluminum alloy, weldment coupler for aluminum pipe connections at 45° or 90°.
Note: To specify coupler for SCH 80 pipe, add (H) to catalog number.
Example: WLBI45-4949H
Also available with other angles. Please contact factory for specifications.

Casting Alloy: 356-T6 Aluminum

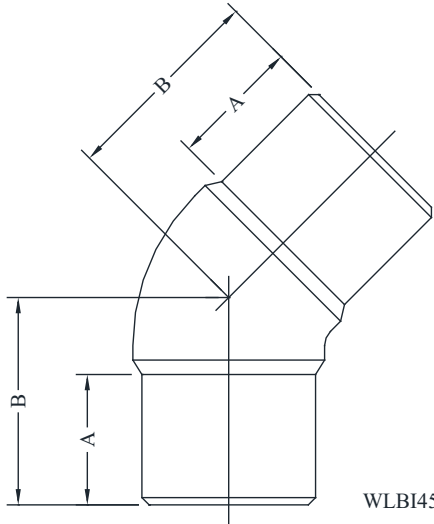

WLBI45

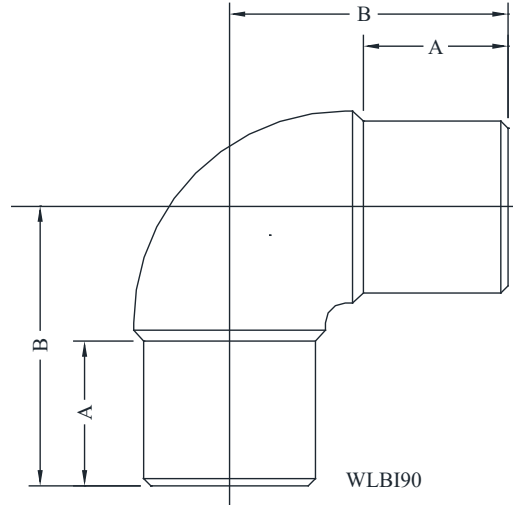

WLBI90

CATALOG NUMBER	PIPE SIZE	DIMENSIONS - INCHES		WEIGHT (POUNDS)
	MAIN & TAP (NPS)	A	B	
WLBI45-3939	1	1-1/2	2-1/4	0.50
WLBI45-4949	1-1/4	1-1/4	2-1/4	0.50
WLBI45-5353	1-1/2	1-5/8	2-9/16	0.50
WLBI45-5858	2	2	2-13/16	1.00
WLBI45-6060	2-1/2	2-3/8	3-7/16	1.00
WLBI45-6262	3	2-7/8	4-3/8	2.25
WLBI45-6363	3-1/2	2-7/8	4-5/16	2.50
WLBI45-6464	4	2-3/4	4-1/2	3.35
WLBI45-6767	5	4-1/2	6-7/16	8.50
WLBI45-6969	6	4-1/2	7-3/16	10.25
WLBI90-3939	1	1-1/2	2-3/4	0.50
WLBI90-4949	1-1/4	1-5/16	2-3/4	0.50
WLBI90-5353	1-1/2	1-5/8	3-3/8	0.75
WLBI90-5858	2	2	3-5/8	1.00
WLBI90-6060	2-1/2	2-1/2	4-7/16	2.00
WLBI90-6262	3	2-13/16	5-5/8	3.50
WLBI90-6363	3-1/2	2-3/4	6-1/8	4.25
WLBI90-6464	4	2-5/8	6-1/4	4.15
WLBI90-6767	5	4-11/16	8-5/8	10.00
WLBI90-6969	6	5	9-5/8	14.00

SEFCOR

ALUMINUM COUPLERS

TYPE WLBUA

Weldment Spherical Coupler
Pipe to Pipe

Aluminum alloy weldment variable angle spherical coupler for aluminum pipe connections.

Casting Alloy: 356-T6 Aluminum

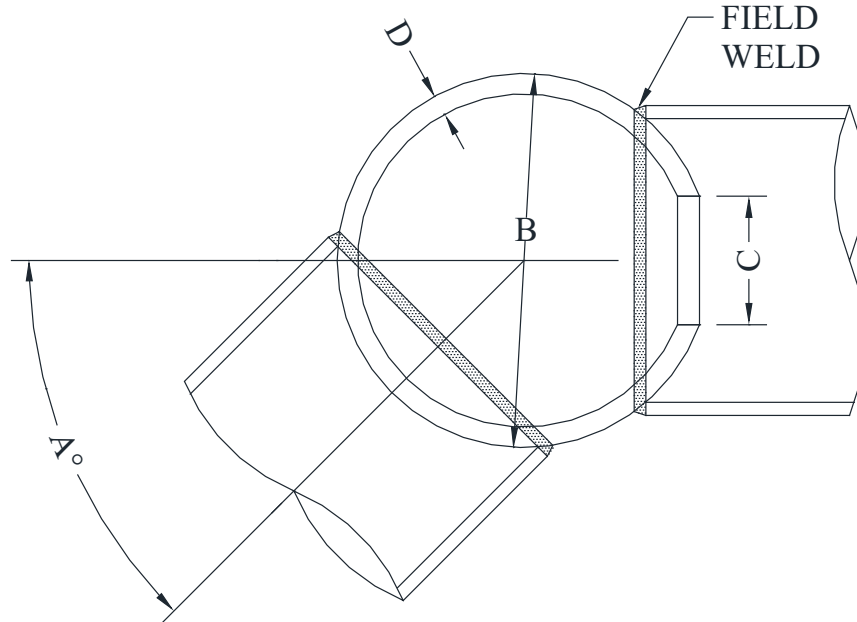

CATALOG NUMBER	CONDUCTOR RANGE	MAX KV	DIMENSIONS - INCHES				WEIGHT (POUNDS)
			A° (MAX)	B	C	D	
WLBUA-5	1-1/2" NPS	230	130°	5	1-1/4	5/16	1.90
	2" NPS		115°				
	2-1/2" NPS		105°				
	3" NPS		90°				
	3-1/2" NPS		80°				
	4" NPS		60°				
WLBUA-8	3" NPS	345	125°	8	2-3/4	7/16	7.00
	3-1/2" NPS		120°				
	4" NPS		110°				
	5" NPS		95°				
	6" NPS		75°				
	8" O.D. TUBE		35°				
WLBUA-12	3" NPS	500	140°	12	2-3/4	3/8	14.30
	3-1/2" NPS		135°				
	4" NPS		130°				
	5" NPS		120°				
	6" NPS		100°				
	8" O.D. TUBE		90°				

SEFCOR

ALUMINUM COUPLERS

TYPE WSC & WSCL

Straight Welded
Pipe Main to Pipe Tap

Aluminum alloy, weldment coupler for aluminum pipe connections.
Note: To specify coupler for SCH 80 pipe, add (H) to catalog number.
Example: WSC-5858H

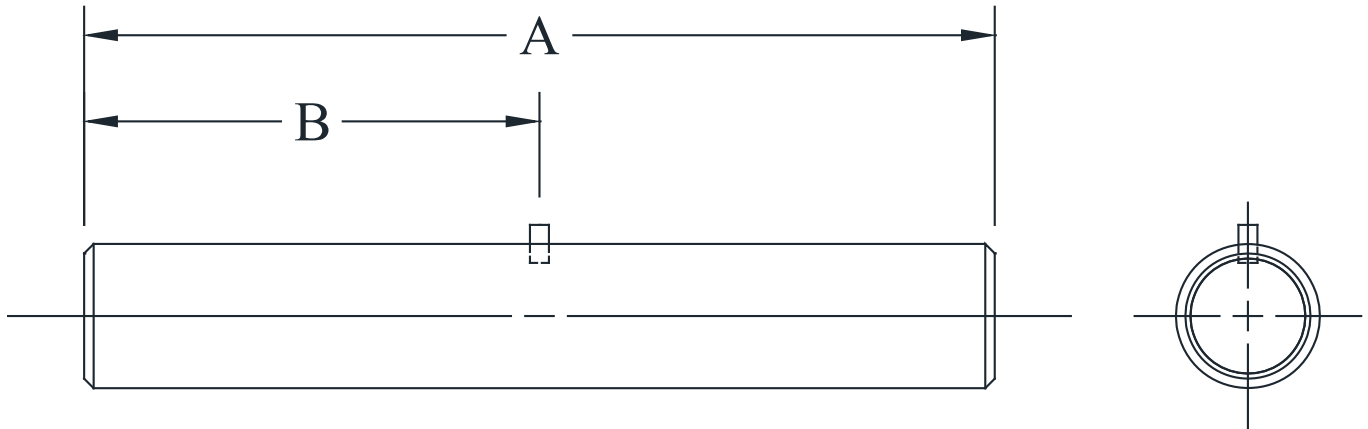

CATALOG NUMBER	CONDUCTOR SIZE (NPS)		DIMENSIONS - INCHES		WEIGHT (POUNDS)
	PIPE MAIN	PIPE TAP	A	B	
WSC-3939	1	1	6	3	0.20
WSC-4949	1-1/4	1-1/4	10	5	1.45
WSC-5353	1-1/2	1-1/2	12	6	1.05
WSC-5858	2	2	12	6	1.65
WSC-6060	2-1/2	2-1/2	15	7-1/2	2.50
WSC-6262	3	3	18	9	3.80
WSC-6363	3-1/2	3-1/2	21	10-1/2	4.60
WSC-6464	4	4	24	12	8.05
WSC-6767	5	5	24	12	8.80
WSC-6969	6	6	24	12	15.45
WSCL-5858	2	2	8-1/4	4-1/8	1.15
WSCL-6060	2-1/2	2-1/2	10	5	1.70
WSCL-6262	3	3	9	4-1/2	1.90

*Consult manufacturer for further details or unlisted applications.

ALUMINUM COUPLERS

TYPE WSCR

Straight Welded

Pipe Main to Pipe Tap

Aluminum alloy weldment reducing straight coupler for aluminum pipe connections. To specify coupler for SCH 80 pipe, add (H) to the catalog number.

Examples: WSCR-6258 MAIN & TAP are both SCH 40
 WSCR-62H58 MAIN & TAP 80 TAP is SCH 40
 WSCR-6258H MAIN is SCH 40 TAP IS SCH 80
 WSCR-62H58H MAIN & TAP are both SCH 80

Casting Alloy:

Clamping Hardware: If Needed

Mounting Hardware: If Needed

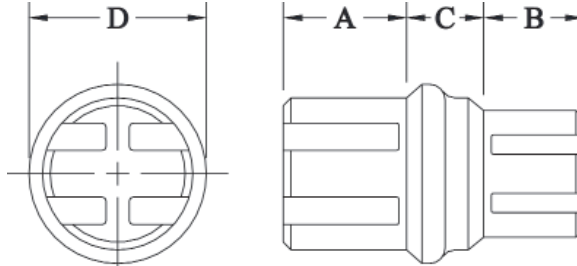

CATALOG NUMBER	CONDUCTOR SIZE (NPS)		DIMENSIONS - INCHES				WEIGHT (POUNDS)
	PIPE MAIN	PIPE TAP	A	B	C	D	
WSCR-5839	2	1	1-3/4	1-1/4	1-1/8	2-3/8	1.85
WSCR-5849	2	1-1/4	2-1/2	2-1/2	1-1/8	2	1.85
WSCR-5853	2	1-1/2	3	3	0	2	1.85
WSCR-6049	2-1/2	1-1/4	2	1-5/8	1-1/8	2-7/8	1.35
WSCR-6053	2-1/2	1-1/2	2	1-5/8	1-1/8	2-7/8	1.35
WSCR-6058	2-1/2	2	2	1-5/8	1-1/4	2-7/8	1.35
WSCR-6253	3	1-1/2	2-1/4	2	1-1/4	3-1/2	1.35
WSCR-6258	3	2	2-1/4	2	1-1/4	3-1/2	1.35
WSCR-6260	3	2-1/2	2-1/4	2	1-1/4	3-1/2	1.35
WSCR-6358	3-1/2	2	2	2	1-1/4	4	5.75
WSCR-6360	3-1/2	2-1/2	2	2	1-1/4	4	5.75
WSCR-6362	3-1/2	3	2	2	1-1/4	4	5.75
WSCR-6458	4	2	2-1/2	1-1/4	1-1/8	4-1/2	5.00
WSCR-6460	4	2-1/2	2-1/2	2-1/8	1-1/2	4-1/2	5.50
WSCR-6462	4	3	2	2-1/8	7/8	4-1/2	1.75
WSCR-6463	4	3-1/2	2-1/2	1/2	0	5-1/2	3.00
WSCR-6760	5	2-1/2	3	2-1/8	2	5-9/16	6.75
WSCR-6762	5	3	3	2-1/8	2	5-9/16	6.75
WSCR-6763	5	3-1/2	3	2-1/8	2	5-9/16	6.75
WSCR-6764	5	4	3	2	1-7/8	5-9/16	6.75
WSCR-6962	6	3	2-3/8	1-1/4	1	6-5/8	4.00
WSCR-6964	6	4	1-1/2	1-1/4	0	6-5/8	3.50
WSCR-6967	6	5	2-1/2	2-1/2	1-1/4	6-5/8	11.75

* Consult manufacturer for further details or unlisted applications.

ALUMINUM COUPLERS

TYPE WXCF

Welded Expansion
Pipe Main to Pipe Tap

Casting Alloy: 356-T6 Aluminum
Laminated Straps: 1100-0 Aluminum
Alignment Guide: 6061-T6 Aluminum

Aluminum alloy weldment expansion coupler for aluminum pipe connections. Features tubular aluminum alignment guide that is field welded to one end of pipe run.

To specify coupler for SCH 80 pipe, add (H) to catalog number.

Examples: WXCF-3939H

To specify no alignment guide, add (-NG) to catalog number.

Examples: WXCF-3939-NG

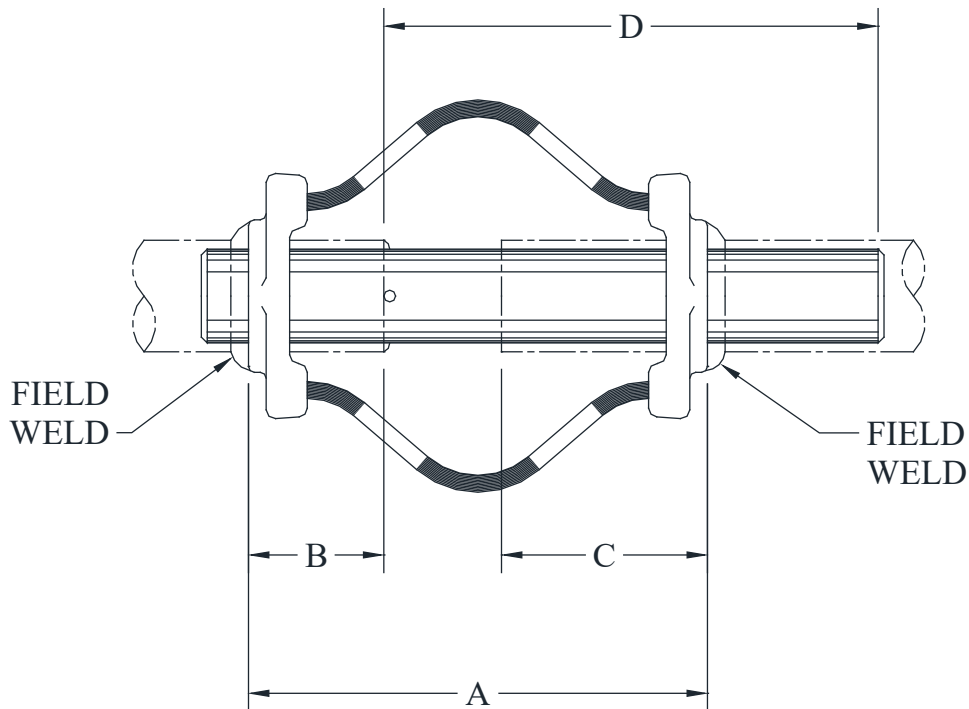

CATALOG NUMBER	CONDUCTOR SIZE (NPS)		DIMENSIONS - INCHES				WEIGHT (POUNDS)
	PIPE MAIN	PIPE TAP	A	B	C	D	
WXCF-3939	1	1	9-1/2	2-1/2	4-1/8	9	3.15
WXCF-4949	1-1/8	1-1/8	9-1/2	2-1/2	4-1/8	9	3.65
WXCF-5353	1-1/2	1-1/2	9-1/2	2-1/2	4-1/8	9	3.95
WXCF-5858	2	2	9-3/4	2-7/8	4-3/8	10-5/8	5.75
WXCF-6060	2-1/2	2-1/2	9-3/4	2-7/8	4-3/8	10-1/2	8.60
WXCF-6262	3	3	12	3	5-1/2	12	10.90
WXCF-6363	3-1/2	3-1/2	11	3	5-1/2	12	13.60
WXCF-6464	4	4	12-1/4	3-1/8	5-5/8	12	18.15
WXCF-6767	5	5	16	3-3/4	8-1/4	17	31.70
WXCF-6969	6	6	16-1/2	4	8-1/2	14-1/4	46.40

BRONZE COUPLERS

TYPE ACCC-BR

Straight Bolted

Cable Main to Cable Tap

Bronze alloy coupler for copper cable main to copper cable tap connections. Clamping bolts hex-stops for one-wrench installation.

Casting Alloy: Electrical Bronze

Clamping Hardware: Silicon Bronze

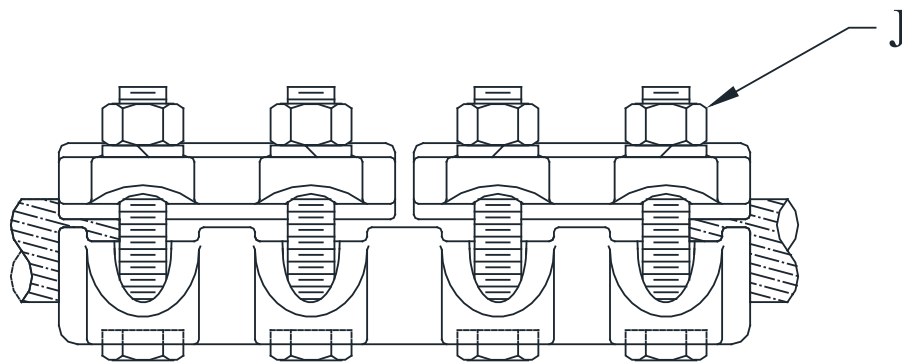
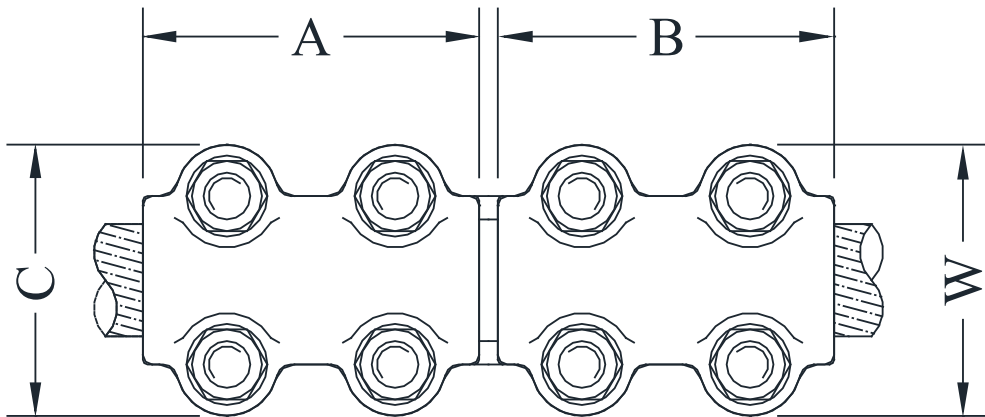

CATALOG NUMBER	CONDUCTOR RANGE		DIMENSIONS - INCHES					WEIGHT (POUNDS)
	MAIN (CU)	TAP (CU)	A	B	W	C	J	
ACCC-1313-BR	#4 - 250 MCM	#4 - 250 MCM	3	3	2-3/8	2-3/8	1/2	4.90
ACCC-2424-BR	350 - 650 MCM	350 - 650 MCM	4	4	2-7/8	2-7/8	1/2	11.50
ACCC-3939-BR	850 - 1250 MCM	850 - 1250 MCM	4-1/4	4-1/4	3-1/4	3-1/4	1/2	10.85
ACCC-4949-BR	1500 - 2000 MCM	1500 - 2000 MCM	4-3/4	4-3/4	3-7/8	3-7/8	5/8	17.60
ACCC-1139-1139-BR	4/0 - 1250 MCM	4/0 - 1250 MCM	4-1/4	4-1/4	3-1/4	3-1/4	1/2	14.15

BRONZE COUPLERS

TYPE CCT

Straight Bolted
Pipe Main to Pipe Tap

Casting Alloy: Electrical Bronze
Clamping Hardware: Silicon Bronze

Bronze alloy coupler for connecting pipe.
Clamping bolts have hex-stops for one wrench installation.

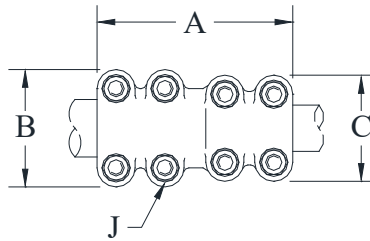

CATALOG NUMBER	CONDUCTOR SIZE (NPS)		DIMENSIONS - INCHES				WEIGHT (POUNDS)
	PIPE MAIN	PIPE TAP	A	B	C	J	
CCT-3030	3/4	3/4	4-1/4	2-3/8	2-3/8	3/8	3.20
CCT-3930	1	3/4	4-7/16	2-11/16	2-3/8	3/8	2.75
CCT-3939		1	4-1/4	2-7/8	2-7/8	3/8	4.85
CCT-4930	1-1/4	3/4	4-1/2	3	2-3/8	3/8	3.55
CCT-4939		1	4-1/2	3	2-11/16	3/8	5.30
CCT-4949		1-1/4	5-3/4	3-3/8	3-3/8	1/2	6.75
CCT-5339	1-1/2	1	4-1/2	3-1/4	2-11/16	3/8	5.85
CCT-5349		1-1/4	6	3-5/8	3-3/8	1/2	6.80
CCT-5353		1-1/2	5-3/4	3-5/8	3-5/8	1/2	7.95
CCT-5839	2	1	4-1/2	3-3/4	2-11/16	3/8	3.85
CCT-5849		1-1/4	6	4-1/8	3-3/8	1/2	5.90
CCT-5853		1-1/2	5-7/8	4-1/8	3-5/8	1/2	9.00
CCT-5858		2	5-5/8	4-1/8	4-1/8	1/2	9.00
CCT-6049	2-1/2	1-1/4	6-1/8	4-5/8	3-3/8	1/2	9.40
CCT-6053		1-1/2	7-1/8	4-3/4	3-7/8	1/2	11.75
CCT-6058		2	6	4-5/8	4-1/8	1/2	12.00
CCT-6060		2-1/2	5-5/8	4-5/8	4-5/8	1/2	13.15
CCT-6253	3	1-1/2	6	5-1/4	3-5/8	1/2	11.75
CCT-6258		2	6-1/8	5-1/4	4-1/8	1/2	12.40
CCT-6260		2-1/2	6	5-1/4	4-5/8	1/2	15.10
CCT-6262		3	7-3/8	5-5/8	5-5/8	5/8	18.50
CCT-6360	3-1/2	2-1/2	6-1/8	5-3/4	4-3/4	1/2	12.20
CCT-6362		3	12-5/8	6-1/8	5-3/4	1/2	31.75
CCT-6363		3-1/2	7-3/4	6-1/4	6-1/4	5/8	21.30
CCT-6460	4	2-1/2	6-1/2	6-7/8	4-5/8	5/8	19.25
CCT-6462		3	6-15/16	6-5/8	5-5/8	5/8	21.15
CCT-6463		3-1/2	7-1/2	6-7/8	6-1/4	5/8	22.75
CCT-6464		4	8	6-3/4	6-3/4	5/8	24.00

*Consult manufacturer for further details or unlisted applications.

BRONZE COUPLERS

TYPE CXT

Bolted Expansion
Pipe Main to Pipe Tap

Casting Alloy: Electrical Bronze
Laminations: Copper
Clamping Hardware: Silicon Bronze

Bronze alloy expansion coupler for copper pipe connections. Clamping bolts have hex-stops for one-wrench installation. If guide is to be omitted, add suffix "-NG" to the catalog number. Example: CXT-3030-NG
Add suffix (H) to catalog number for SCH 80 pipe. Example: CXT-3030-H
For tinned braid shunts add suffix "B" to catalog number. Example: CXT-3030-B

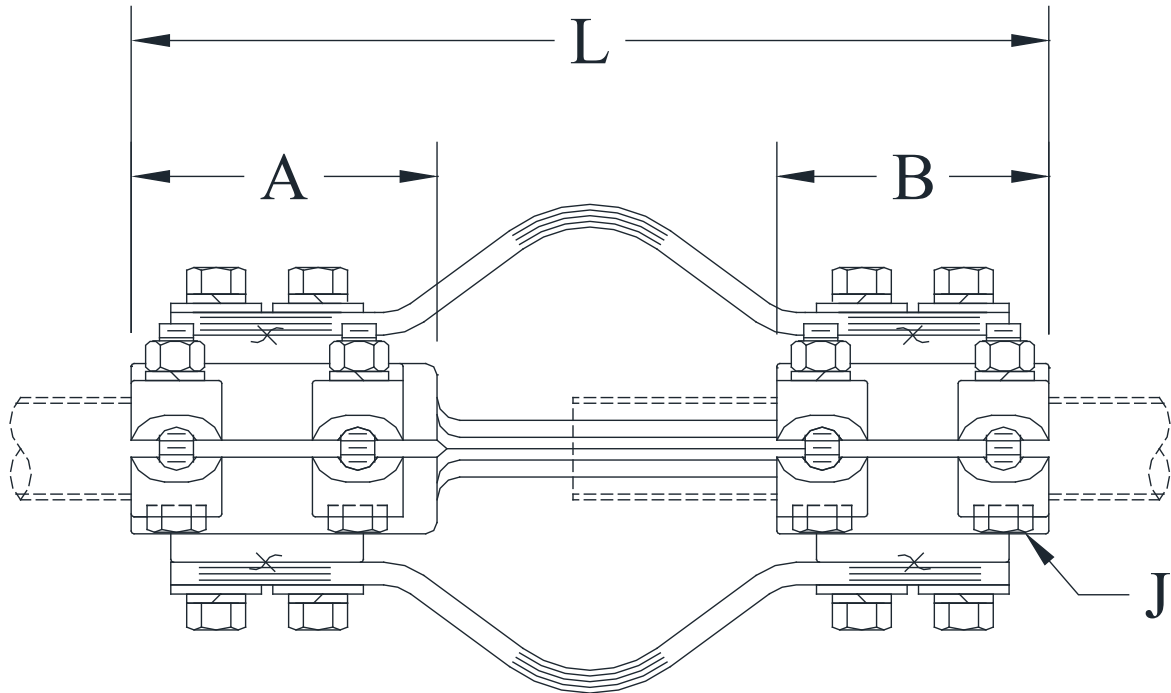

CATALOG NUMBER	CONDUCTOR SIZE (NPS)		DIMENSIONS - INCHES				WEIGHT (POUNDS)
	PIPE MAIN	PIPE TAP	L	A	B	J	
CXT-3030	3/4	3/4	9-3/4	3	3	3/8	10.00
CXT-3939	1	1	10-1/8	3-3/8	3	3/8	9.75
CXT-4949	1-1/4	1-1/4	12	4	3-1/2	1/2	16.45
CXT-5353	1-1/2	1-1/2	13	3-1/2	3-1/2	1/2	17.90
CXT-5858	2	2	12	2-1/2	2-1/2	1/2	26.75
CXT-6060	2-1/2	2-1/2	17-5/8	4	3-5/8	1/2	35.45
CXT-6262	3	3	14-7/8	4-3/8	4	5/8	45.15
CXT-6363	3-1/2	3-1/2	12	3	3	5/8	57.10
CXT-6464	4	4	15	4-1/2	4	5/8	77.10

BRONZE COUPLERS

TYPE ETRCT

Straight Bolted

Pipe Main to Cable Tap

Bronze alloy coupler for copper pipe to copper cable.
Clamping bolts have hex-stops for one wrench installation.
All sizes furnished with reversible cable caps.
1/2" clamping available upon request.

Casting Alloy: Electrical Bronze
Clamping Hardware: Silicon Bronze

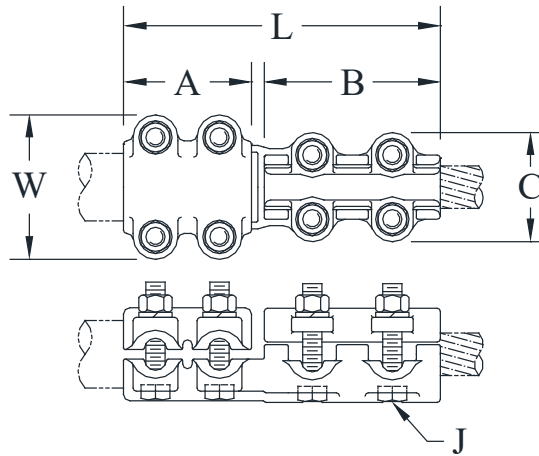

CATALOG NUMBER	CONDUCTOR RANGE		DIMENSIONS - INCHES						WEIGHT (POUNDS)
	PIPE MAIN (NPS)	CABLE TAP	L	A	B	W	C	J	
ETRCT-3011	3/4	#6 - 4/0 STR	5-9/16	2	3-1/4	2-3/8	1-7/8	3/8	2.65
ETRCT-3014		#4 - 300 MCM	6-1/16	2-3/8	3-1/4	2-1/2	2-1/8	3/8	3.20
ETRCT-3914	1	#4 - 300 MCM	5-1/2	2	3-3/8	3	2	3/8	3.50
ETRCT-3920		1/0 - 500 MCM	6-3/16	2-1/2	3-7/16	2-13/16	2-1/8	3/8	3.70
ETRCT-4914	1-1/4	#4 - 300 MCM	6-1/8	2-1/2	3-1/4	3-5/16	2	3/8	4.00
ETRCT-4920		1/0 - 500 MCM	5-7/8	2-1/4	3-1/2	3	2-3/16	3/8	4.05
ETRCT-4934		4/0 - 1000 MCM	7-1/2	2-3/4	4	3-5/8	2-15/16	1/2	7.10
ETRCT-5314	1-1/2	#4 - 300 MCM	5-15/16	2-1/4	3-3/8	3-1/4	2	3/8	5.45
ETRCT-5320		1/0 - 500 MCM	6-1/2	2-9/16	3-1/2	3-5/8	2-1/8	3/8	4.45
ETRCT-5334		4/0 - 1000 MCM	7-3/4	3	4	3-7/8	2-15/16	1/2	7.30
ETRCT-5814	2	#4 - 300 MCM	6-1/4	2-1/2	3-1/8	3-3/4	2	3/8	4.75
ETRCT-5820		1/0 - 500 MCM	6-1/8	2-1/2	3-5/8	3-3/4	2-3/16	3/8	5.60
ETRCT-5834		4/0 - 1000 MCM	8-5/16	3-1/2	4	4-3/8	2-15/16	1/2	7.80
ETRCT-6020	2-1/2	1/0 - 500 MCM	7-1/4	3-1/8	3-1/2	4-3/4	2-1/8	1/2	6.55
ETRCT-6034		4/0 - 1000 MCM	7-5/8	3	4	4-5/8	2-7/8	1/2	8.45
ETRCT-6220	3	1/0 - 500 MCM	7-1/4	3	3-1/2	5-1/4	2-1/8	1/2	6.85
ETRCT-6234		4/0 - 1000 MCM	7-1/4	3	3-1/2	5-3/8	2-15/16	1/2	8.65
ETRCT-6420	4	1/0 - 500 MCM	7-5/8	3-1/8	4	5-5/8	2-1/8	1/2	7.20
ETRCT-6434		4/0 - 1000 MCM	7-5/8	3-1/8	4	5-5/8	2-15/16	1/2	9.35

BRONZE COUPLERS

TYPE LB45 & LB90

Angle Bolted
Pipe Main to Pipe Tap

Bronze alloy coupler for copper pipe connections at 45° & 90°.
Clamping bolts have hex-stops for one-wrench installation.

Casting Alloy: Electrical Bronze
Clamping Hardware: Silicon Bronze

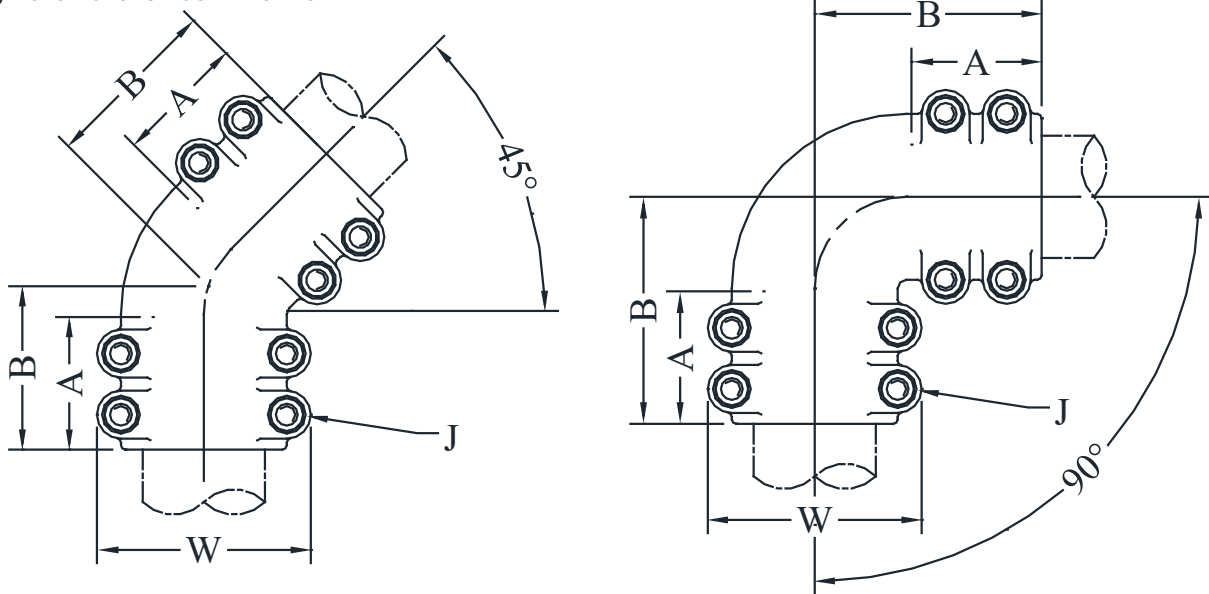

CATALOG NUMBER	CONDUCTOR SIZE (NPS)		DIMENSIONS - INCHES				WEIGHT (POUNDS)
	PIPE MAIN	PIPE TAP	A	B	W	J	
LB45-3030	3/4	3/4	2-1/2	3	3	1/2	3.60
LB45-3939	1	1	2-7/8	3-3/8	3-1/4	1/2	5.00
LB45-4949	1-1/4	1-1/4	2-3/4	3-1/2	3-1/4	1/2	7.25
LB45-5353	1-1/2	1-1/2	2-3/4	3-1/2	3-5/8	1/2	7.35
LB45-5858	2	2	2-7/8	3-5/8	4-1/2	1/2	10.00
LB45-6060	2-1/2	2-1/2	3	4-1/16	4-3/4	1/2	12.05
LB45-6262	3	3	3-3/4	4-13/16	5-3/4	5/8	21.50
LB45-6363	3-1/2	3-1/2	4-3/8	5-5/8	6-1/4	5/8	36.30
LB45-6464	4	4	5-1/2	6-15/16	6-11/16	5/8	30.80
LB90-3030	3/4	3/4	2	3-1/4	2-3/8	3/8	4.70
LB90-3939	1	1	2	3-7/16	2-11/16	3/8	4.85
LB90-4949	1-1/4	1-1/4	2-3/4	4-3/4	3-3/8	1/2	7.75
LB90-5353	1-1/2	1-1/2	2-3/4	4-3/4	3-5/8	1/2	9.35
LB90-5858	2	2	3-1/2	5-3/4	4-1/2	1/2	14.70
LB90-6060	2-1/2	2-1/2	3-3/4	6	4-3/4	1/2	23.15
LB90-6262	3	3	3-1/2	6-7/16	5-3/4	5/8	26.00
LB90-6363	3-1/2	3-1/2	3-7/8	7-7/16	6-1/8	5/8	28.00
LB90-6464	4	4	4-1/2	7-1/2	6-3/4	5/8	30.30

SEFCOR

EHV COUPLERS

TYPE ACTCHV

Straight Bolted

Pipe Main to Cable Tap

Casting Alloy: 356-T6 Aluminum
Clamping Hardware: Aluminum Alloy

ALUMINUM • 345kV

Type ACTCHV is designed for corona-free service at 345kV.
Not recommended as a tension connection.

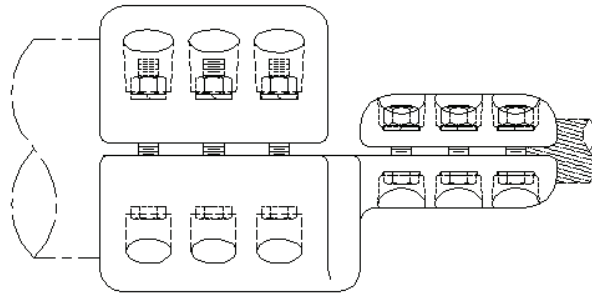
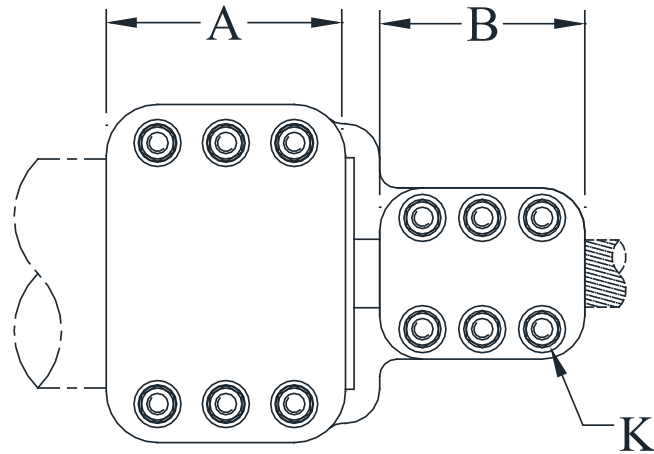

CATALOG NUMBER	PIPE SIZE (NPS)	TAP CONDUCTOR		DIMENSION - INCHES		
		AAC	ACSR	A	B	K
ACTCHV-6052	2-1/2	2250 - 2500 MCM	2156 MCM	4-1/2	6	5/8
ACTCHV-6054		3000 MCM	--	4	6	
ACTCHV-6252	3	2250 - 2500 MCM	2156 MCM	4-1/2	5-7/8	5/8
ACTCHV-6254		3000 MCM	--	4-1/2	6	
ACTCHV-6256		3500 MCM	--	4-1/2	6-1/4	
ACTCHV-6352	3-1/2	2250 - 2500 MCM	2156 MCM	4-1/2	6	5/8
ACTCHV-6354		3000 MCM	--	4-1/2	6	
ACTCHV-6356		3500 MCM	--	5	6-1/4	
ACTCHV-6452	4	2250 - 2500 MCM	2156 MCM	4-1/2	6	5/8
ACTCHV-6454		3000 MCM	--	4-1/2	6	
ACTCHV-6456		3500 MCM	--	4-1/2	6-1/4	
ACTCHV-6752	5	2250 - 2500 MCM	2156 MCM	8-1/4	6	5/8
ACTCHV-6754		3000 MCM	--	8-1/4	6	
ACTCHV-6756		3500 MCM	--	7	6-1/4	

EHV COUPLERS

TYPE ALBHV-V

Bolted Variable Angle Coupler
Pipe To Pipe

Aluminum alloy bolted variable angle coupler for connecting two aluminum pipes at angles between 0° and 60°.

Designed for corona-free service at 345kV and 500kV as indicated.

Contact surfaces are finished and coated with a sealant prior to packaging for shipment.

Casting Alloy: 356-T6 Aluminum
Clamping Hardware: Aluminum Alloy

ALUMINUM • 345 - 500kV

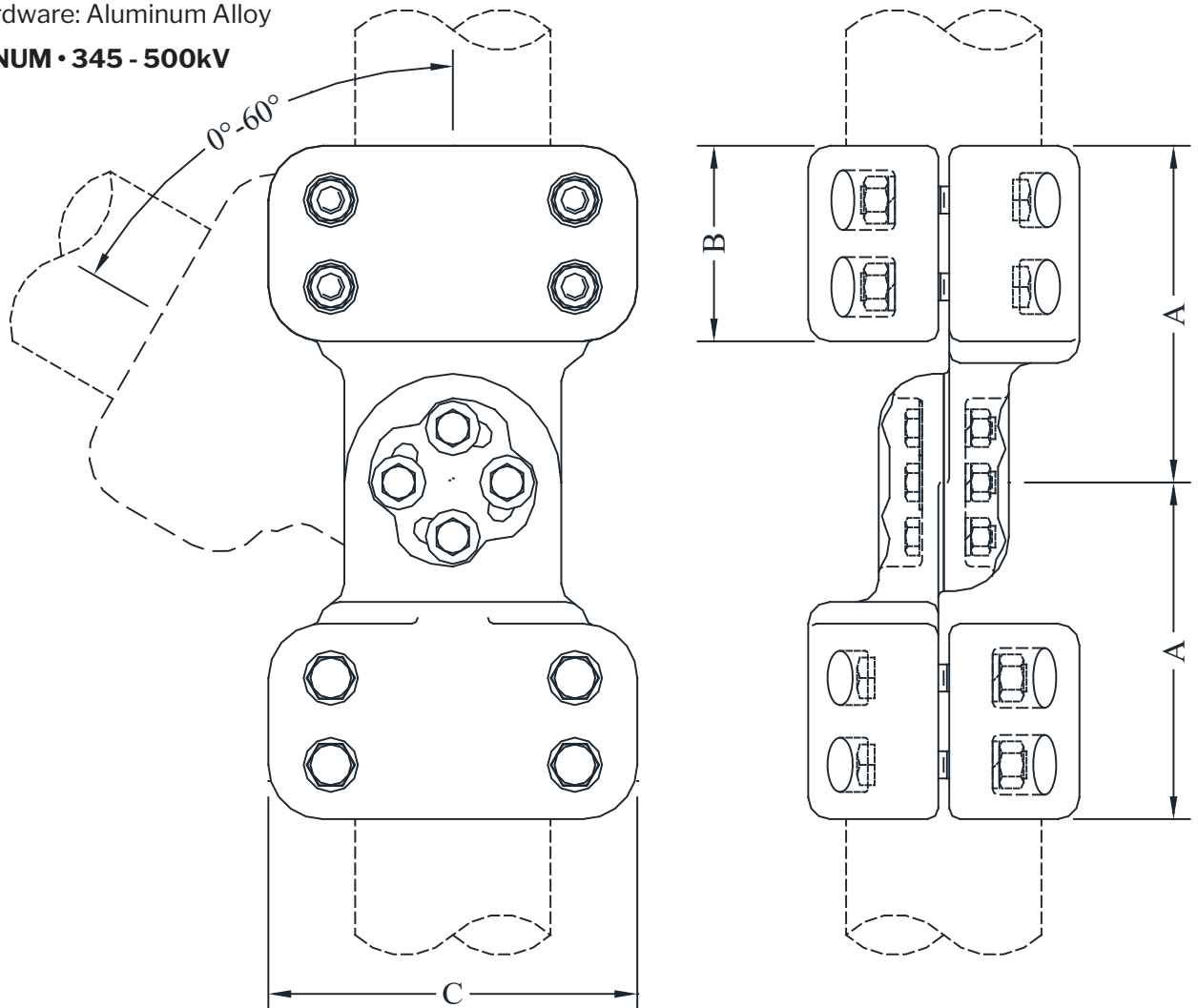

CATALOG NUMBER	PIPE SIZE (NPS)	MAX KV	DIMENSION (INCHES)			WEIGHT (POUNDS)
			A	B	C	
ALBHV-V-5858	2	345	3-3/8	4	5-1/2	10.65
ALBHV-V-6060	2-1/2	500	7	4	6-3/4	24.15
ALBHV-V-6262	3	500	8	4-1/2	7-1/4	24.85
ALBHV-V-6363	3-1/2	500	7-3/4	4-1/2	8-1/2	28.45
ALBHV-V-6464	4	500	7-3/4	4-1/2	8-1/2	25.57
ALBHV-V-6767*	5	500	11-3/4	8-1/4	9-1/2	52.49
ALBHV-V-6969*	6	500	10-7/8	7	9-7/8	50.94

*SIX CLAMPING BOLTS PER CAP

SEFCOR

EHV COUPLERS

TYPE ASCTHV

Bolted Coupler
Pipe to Pipe

Casting Alloy: 356-T6 Aluminum
Clamping Hardware: Aluminum Alloy

ALUMINUM • 345 - 500kV

Type ASCTHV is designed for corona-free service within the voltage limitations of the tubular conductor size. Separate caps provide independent clamping action for each member.

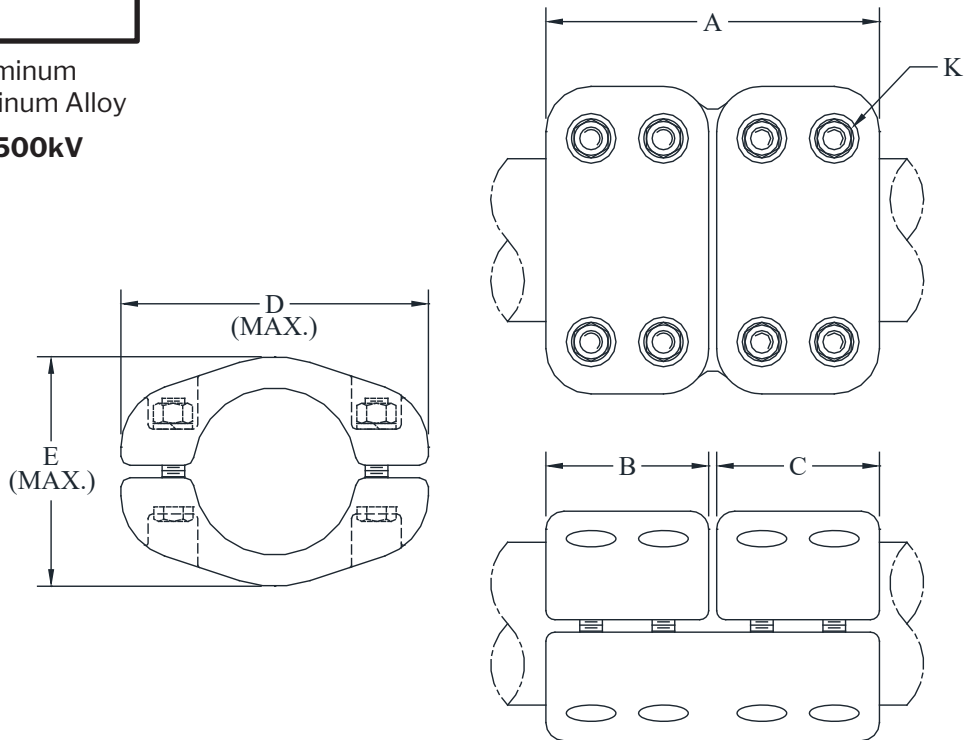

CATALOG NUMBER	PIPE SIZE (NPS)		MAX KV	DIMENSIONS - INCHES					
	MAIN	TAP		A	B	C	D	E	K
ASCTHV-5858	2	2	345	12-3/4	4	4	5-1/2	3-1/2	1/2
ASCTHV-6058	2-1/2	2	345	13-1/2	4-1/2	4	7-1/4	5-1/4	1/2
ASCTHV-6060		1-1/2	345	8-1/4	4	4	6-3/4	4-1/8	5/8
ASCTHV-6258	3	2	345	8	4	3-3/4	7	5	1/2
ASCTHV-6260		2-1/2	345	8-3/4	4-1/2	4	7-1/2	5-1/4	5/8
ASCTHV-6262		3	500	9-1/4	4-1/2	4-1/2	7-1/2	5-1/4	5/8
ASCTHV-6360	3-1/2	2-1/2	345	8-3/4	4-1/2	4	7-1/8	5-1/4	5/8
ASCTHV-6362		3	500	14-5/8	4-1/2	5	7-1/8	5-1/2	5/8
ASCTHV-6363		3-1/2	500	9-1/4	4-1/2	4-1/2	8	5-1/8	5/8
ASCTHV-6462	4	3	500	14-1/2	4-1/2	4-1/2	8-1/2	6-1/4	5/8
ASCTHV-6463		3-1/2	500	14-3/4	4-1/2	5	8-1/2	6-1/4	5/8
ASCTHV-6464		4	500	9-1/4	4-1/2	4-1/2	8-1/2	6-3/8	5/8
ASCTHV-6762	5	3	500	9-1/2	4-3/4	4-1/2	8-3/4	6-3/4	5/8
ASCTHV-6764		4	500	9-1/2	4-3/4	4-1/2	10	6-3/4	5/8
*ASCTHV-6767		5	500	16-3/4	7	7	9-1/2	7-1/8	5/8
ASCTHV-6962	6	3	500	17-1/4	7	4-1/2	9-7/8	8-3/4	5/8
ASCTHV-6964		4	500	17-3/8	7	4-1/2	9-7/8	8-3/4	5/8
*ASCTHV-6969		6	500	14-3/8	7	7	9-7/8	8-3/4	5/8

*12 Clamping Bolts

SEFCOR

EHV COUPLERS

TYPE WBCHV

Welded/Bolted Coupler

Pipe to Pipe

Casting Alloy: 356-T6 Aluminum
Clamping Hardware: Aluminum Alloy

ALUMINUM • 345 - 500kV

Type WBCHV is designed for corona-free service at 345kV and 500kV as shown.

Optional end bell is for 345kV removable segment application.

End bell is inserted when segment is removed.

When required as part of the connector assembly, add suffix -EB to catalog number.

Example: WBCHV-67-EB

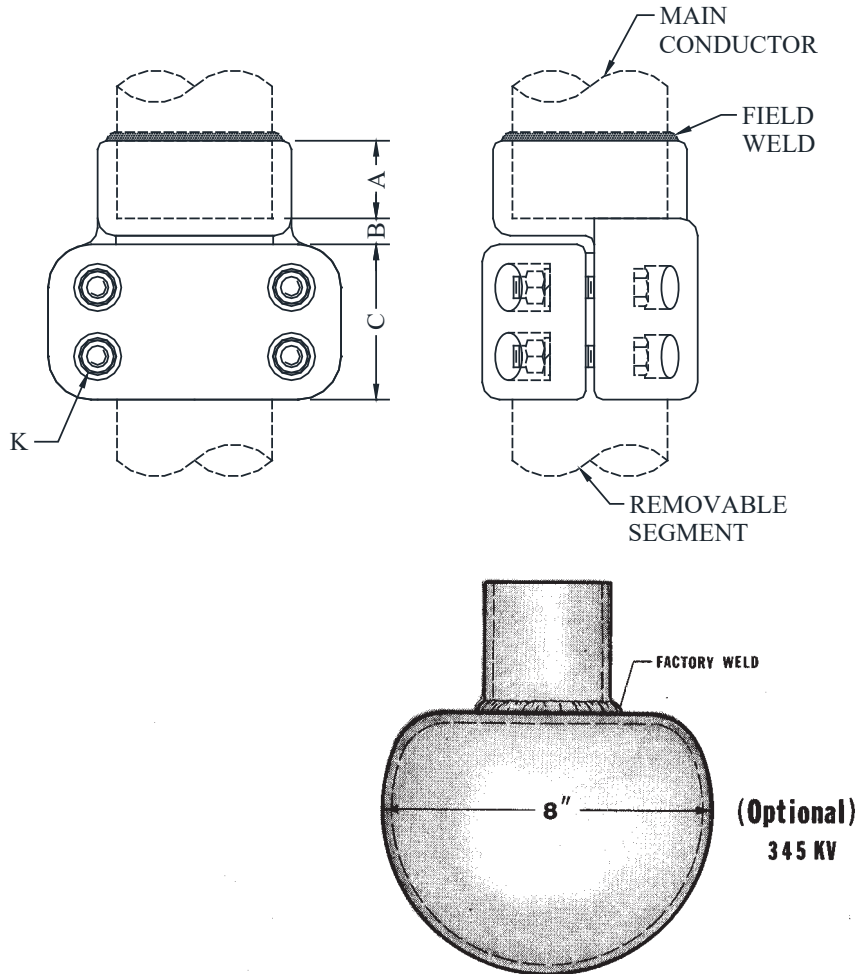

CATALOG NUMBER	PIPE SIZE (NPS)	MAX KV	DIMENSIONS - INCHES			
			A	B	C	K
WBCHV-58	2	345	1-1/2	3/4	3-3/4	1/2
WBCHV-60	2-1/2	345	1-3/4	3/4	4	5/8
WBCHV-62	3	500	1-3/4	7/8	4-1/2	5/8
WBCHV-63	3-1/2	500	1-7/8	7/8	4-1/2	5/8
WBCHV-64	4	500	2-1/4	3/4	4-1/2	5/8
*WBCHV-67	5	500	2-7/8	3/4	8-1/4	5/8
*WBCHV-69	6	500	3	1-1/4	7	5/8

*Bolted Section Has Six Clamping Bolts

EHV COUPLERS

TYPE WETC2

Welded Bifurcating
Pipe to Cable

Type WETC2 is a one-piece weldment connector designed for 345kV service.
Not recommended for tension connection.

Casting Alloy: 356-T6 Aluminum

ALUMINUM • 345kV

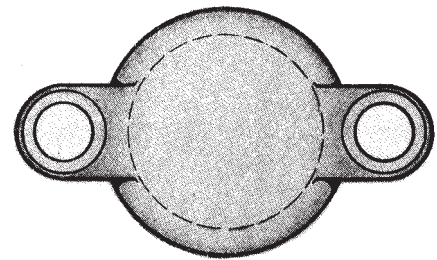
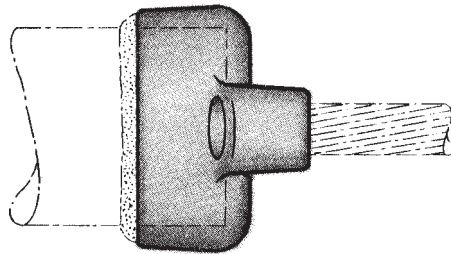
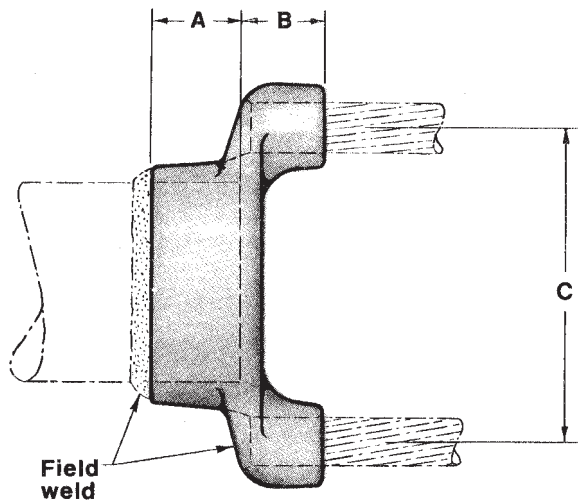

CATALOG NUMBER	PIPE SIZE (NPS)	CABLE SIZE	DIMENSIONS - INCHES		
		AAC	A	B	C
WETC2-6035	2-1/2	1000 - 1033 MCM	1-1/2	1-7/8	5-1/2
WETC2-6039		1250 - 1272 MCM	1-1/2	2	5-5/8
WETC2-6235	3	1000 - 1033 MCM	1-3/4	1-7/8	6-1/8
WETC2-6239		1250 - 1272 MCM	1-3/4	2	6-1/4
WETC2-6335	3-1/2	1000 - 1033 MCM	1-7/8	1-7/8	6-5/8
WETC2-6339		1250 - 1272 MCM	1-7/8	2	6-3/4
WETC2-6341		1351 - 1431 MCM	1-7/8	2-1/4	6-7/8
WETC2-6435	4	1000 - 1033 MCM	2-1/2	1-7/8	7-1/8
WETC2-6439		1250 - 1272 MCM	2-1/2	2	7-1/4
WETC2-6441		1351 - 1431 MCM	2-1/2	2-1/4	7-3/8
WETC2-6443		1500 - 1590 MCM	2	3-5/8	8
WETC2-6739	5	1250 - 1272 MCM	2-1/2	2	8-1/4
WETC2-6741		1351 - 1431 MCM	2-1/2	2-1/4	8-3/8
WETC2-6743		1500 - 1590 MCM	2-7/8	3-5/8	8

SEFCOR

EHV COUPLERS

TYPE WFTD

Welded/Bolted Bifurcating
Pipe to Two Flat Pads

Type WFTD is designed for corona-free service at the voltage levels shown, when used with two EHV compression terminals to form a bifurcating pipe-cable joint.
NOTE: (2) AA-1094 hardware shields are furnished with catalog number.

Casting Alloy: 356-T6 Aluminum
Pad Mounting Hardware: Aluminum Alloy

ALUMINUM • 345 - 500kV

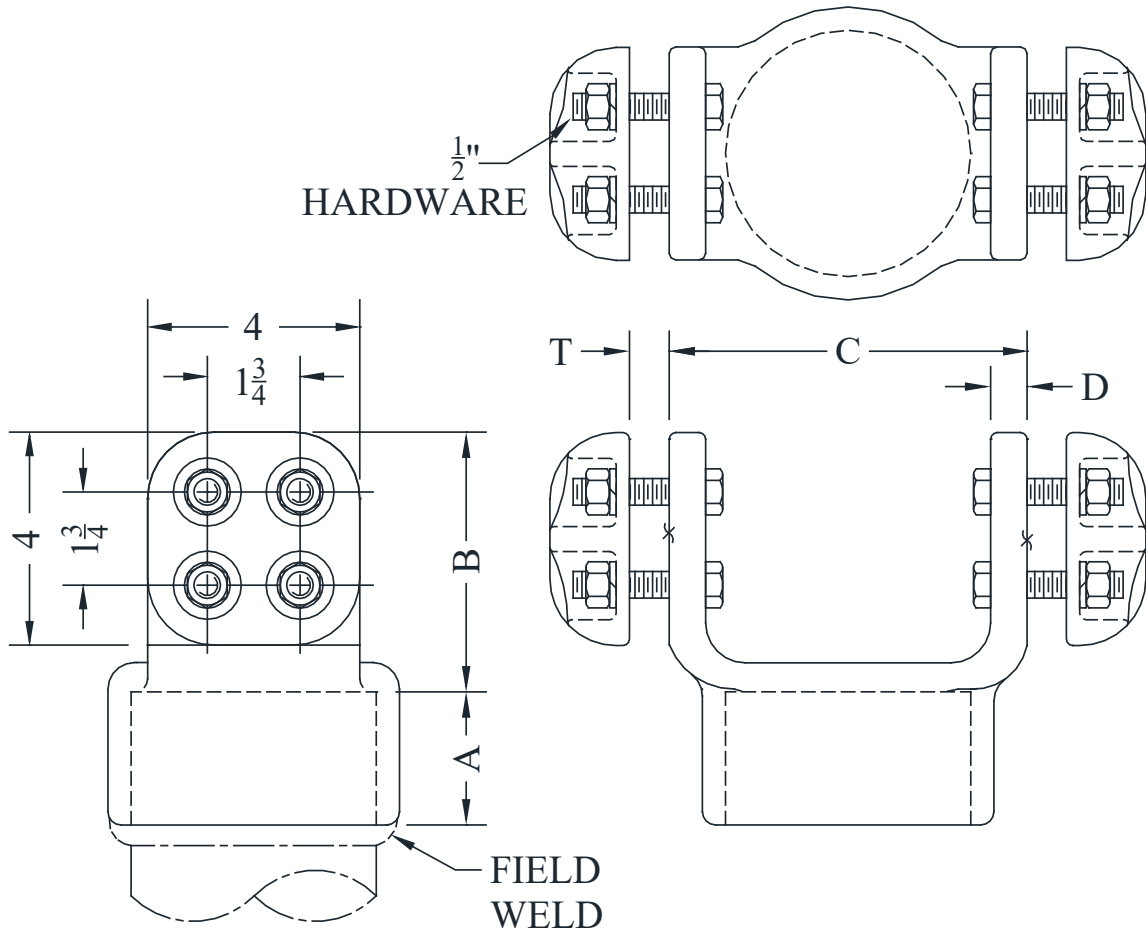

CATALOG NUMBER	PIPE SIZE (NPS)	MAX KV	DIMENSIONS - INCHES					WEIGHT (POUNDS)
			A	B	C	D	T	
WFTD-58-4B	2	345	1-1/2	4-3/4	5	5/8	3/4	7.30
WFTD-60-4B	2-1/2	345	1-1/2	4-3/4	5	5/8	3/4	7.35
WFTD-62-4B	3	345	1-3/4	4-7/8	5-3/8	3/4	7/8	7.85
WFTD-63-4B	3-1/2	500	1-7/8	4-7/8	6	3/4	7/8	7.75
WFTD-64-4B	4	500	2-1/2	4-7/8	6-3/4	11/16	7/8	7.50
WFTD-67-4B	5	500	2-5/8	5	7-1/2	7/8	3/4	11.35
WFTD-69-4B	6	500	2-3/4	5	8-1/8	7/8	1	14.10

EHV COUPLERS

TYPE WLBI-HV

Welded Angle Coupler
Pipe to Pipe

Casting Alloy: 356-T6 Aluminum

ALUMINUM • 345 - 500kV

Type WLBI-HV angle couplers are designed and factory-finished for corona-free service at the maximum voltages shown. For voltage levels higher than shown in the table it is recommended that large-radius field bends be used.

Note: To specify coupler for SCH 80 pipe, add (H) to catalog number.

Example: WLBI45-6060H-HV

Also available with other angles. Please contact factory for specifications.

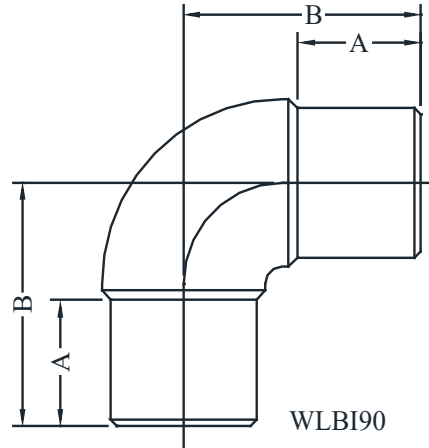
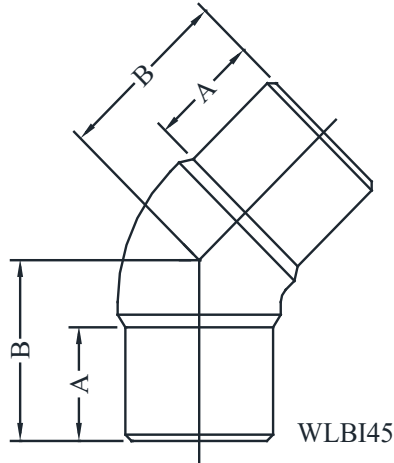

CATALOG NUMBER	PIPE SIZE (NPS)	MAX KV	DIMENSION - INCHES		WEIGHT (POUNDS)
			A	B	
WLBI45-6060-HV	2-1/2" SCH 40	345	2-3/8	3-3/8	1.00
WLBI45-6060H-HV	2-1/2" SCH 80	345	2-3/8	3-1/2	1.50
WLBI45-6262-HV	3" SCH 40	345	2-7/8	4-5/16	2.25
WLBI45-6262H-HV	3" SCH 80	345	2-7/8	4-5/16	2.25
WLBI45-6363-HV	3-1/2" SCH 40	345	2-7/8	4-5/16	2.50
WLBI45-6363H-HV	3-1/2" SCH 80	345	2-3/4	4-7/16	3.25
WLBI45-6464-HV	4" SCH 40	500	2-3/4	4-1/2	3.35
WLBI45-6464H-HV	4" SCH 80	500	2-3/4	4-5/8	3.50
WLBI45-6767-HV	5" SCH 40	500	4-1/2	6-3/8	8.50
WLBI45-6767H-HV	5" SCH 80	500	4-1/2	6-3/8	8.50
WLBI45-6969-HV	6" SCH 40	500	4-1/2	7	10.25
WLBI45-6969H-HV	6" SCH 80	500	5-1/8	7	12.00
WLBI90-6060-HV	2-1/2" SCH 40	345	2-1/2	4-7/16	2.00
WLBI90-6060H-HV	2-1/2" SCH 80	345	2-3/8	4-9/16	1.75
WLBI90-6262-HV	3" SCH 40	345	2-7/8	5-5/8	3.50
WLBI90-6262H-HV	3" SCH 80	345	2-7/8	5-5/8	2.75
WLBI90-6363-HV	3-1/2" SCH 40	345	2-3/4	6-1/8	4.25
WLBI90-6363H-HV	3-1/2" SCH 80	345	2-3/4	6-3/16	4.75
WLBI90-6464-HV	4" SCH 40	500	2-5/8	6-1/4	4.15
WLBI90-6464H-HV	4" SCH 80	500	2-5/8	6-3/8	4.75
WLBI90-6767-HV	5" SCH 40	500	4-11/16	8-5/8	10.00
WLBI90-6767H-HV	5" SCH 80	500	4-5/8	8-5/8	9.25
WLBI90-6969-HV	6" SCH 40	500	5	9-5/8	14.00
WLBI90-6969H-HV	6" SCH 80	500	5	9-1/2	12.75

EHV COUPLERS

TYPE WLBUA

Weldment Spherical Coupler

Pipe to Pipe

Casting Alloy: 356-T6 Aluminum

ALUMINUM • 345 - 500kV

Aluminum alloy weldment variable angle spherical coupler for aluminum pipe connections.

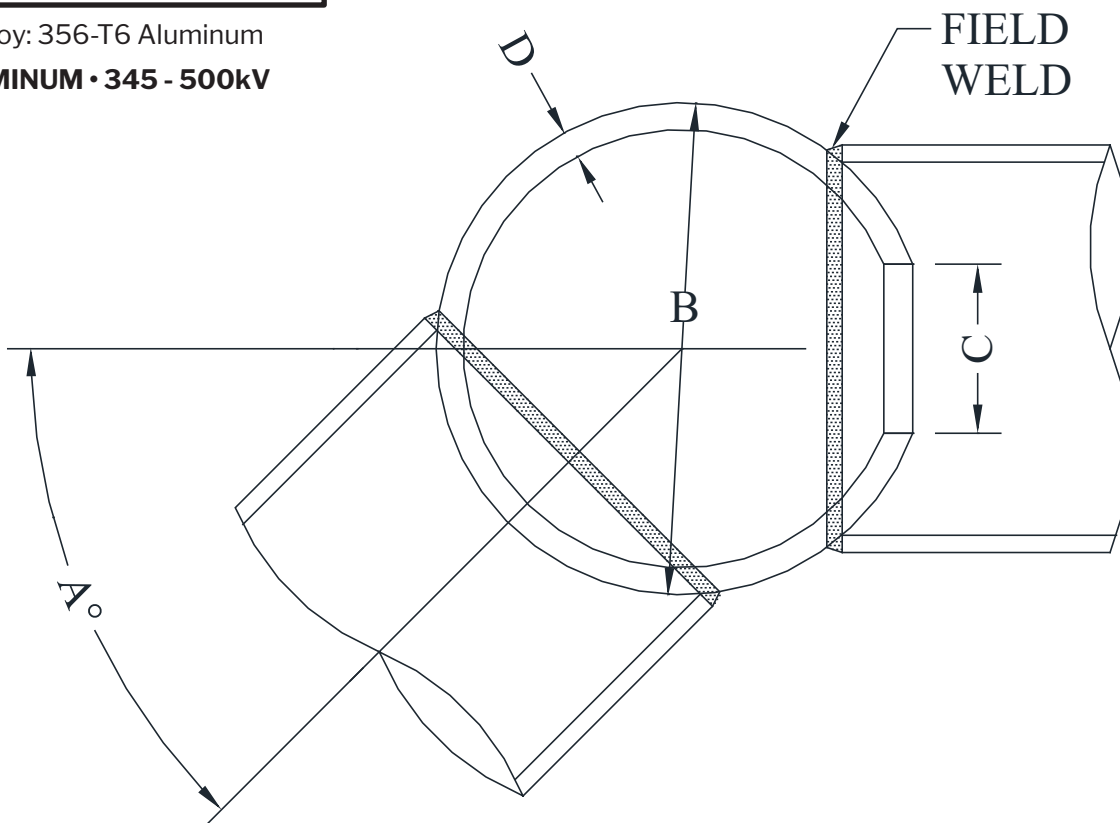

CATALOG NUMBER	CONDUCTOR RANGE	MAX KV	DIMENSIONS - INCHES				WEIGHT (POUNDS)
			A° (MAX)	B	C	D	
WLBUA-8	3" NPS	345	125°	8	2-3/4	7/16	7.5
	3 1/2" NPS		120°				
	4" NPS		110°				
	5" NPS		95°				
	6" NPS		75°				
	8" O.D. TUBE		35°				
WLBUA-12	3" NPS	500	140°	12	2-3/4	3/8	15.00
	3-1/2" NPS		135°				
	4" NPS		130°				
	5" NPS		120°				
	6" NPS		100°				
	8" O.D. TUBE		90°				

EHV COUPLERS

TYPE WSC/WSR

Welded Couplers/Reducers
Pipe to Pipe

Type WSC is fabricated from 6061-T6 aluminum.
Sized for close-tolerance fit inside the tubular bus.

Type WSCR is cast 356-T6 aluminum.
Sizes listed are for NPS SCH 40 aluminum bus.

Casting Alloy: 356-T6 Aluminum

ALUMINUM • 345 - 500kV

When ordering, please specify when one or both members are SCH 80 pipe.

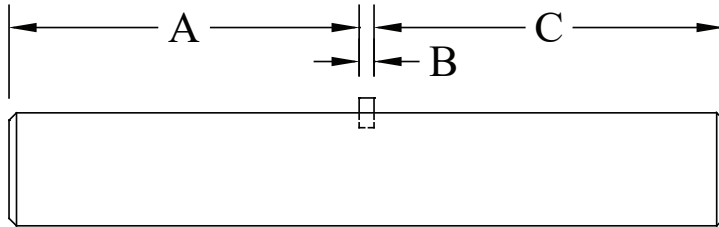

TYPE WSC

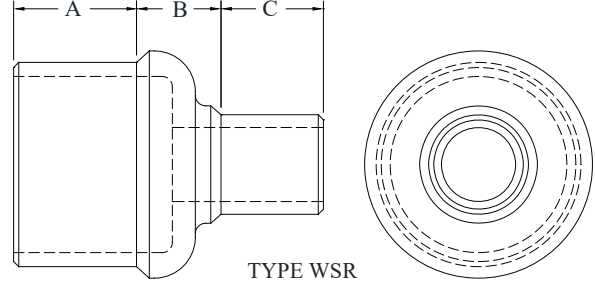

TYPE WSR

CATALOG NUMBER	PIPE SIZE (NPS)		MAX KV	DIMENSION - INCHES		
	MAIN	TAP		A	B	C
WSR-6058	2-1/2" SCH 40	2" SCH 40	345	2	1-1/8	1-3/4
WSC-6060	2-1/2" SCH 40	2-1/2" SCH 40		7-3/8	1/4	7-3/8
WSC-6060H	2-1/2" SCH 80	2-1/2" SCH 80		7-3/8	1/4	7-3/8
WSR-6258	3" SCH 40	2" SCH 40	345	2	1-1/4	1-3/4
WSC-6262	3" SCH 40	3" SCH 40	500	8-7/8	1/4	8-7/8
WSC-6262H	3" SCH 80	3" SCH 80	500	8-7/8	1/4	8-7/8
WSR-6360	3-1/2" SCH 40	2-1/2" SCH 40	345	2-1/2	1-1/2	2-1/2
WSR-6362	3-1/2" SCH 40	3" SCH 40	500	2-1/2	1-1/2	2-1/2
WSC-6363	3-1/2" SCH 40	3-1/2" SCH 40	500	10-3/8	1/4	10-3/8
WSC-6363H	3-1/2" SCH 80	3-1/2" SCH 80	500	10-3/8	1/4	10-3/8
WSR-6460	4" SCH 40	2-1/2" SCH 40	345	3	2	2-1/2
WSR-6462	4" SCH 40	3" SCH 40	500	3	2	3
WSC-6464	4" SCH 40	4" SCH 40	500	11-7/8	1/4	11-7/8
WSC-6464H	4" SCH 80	4" SCH 80	500	11-7/8	1/4	11-7/8
WSR-6762	5" SCH 40	3" SCH 40	500	3	2	3
WSR-6764	5" SCH 40	4" SCH 40		3	2	3
WSC-6767	5" SCH 40	5" SCH 40		11-7/8	1/4	11-7/8
WSC-6767H	5" SCH 80	5" SCH 80		11-7/8	1/4	11-7/8
WSR-6964	6" SCH 40	4" SCH 40	500	3	2	3
WSR-6967	6" SCH 40	5" SCH 40		3-1/2	2	3-1/2
WSC-6969	6" SCH 40	6" SCH 40		11-7/8	1/4	11-7/8
WSC-6969H	6" SCH 80	6" SCH 80		11-7/8	1/4	11-7/8

EHV COUPLERS

TYPE WSTC3

Welded Trifurcating
Pipe to Flat Pads

Type WSTC3 is designed for corona-free service at 345 and 500kV, when used with three (3) compression terminals to form a trifurcating pipe - cable connection. Hardware shields are not required when terminal mounting hardware is arranged so that nuts are inside the bell. Mounting hardware must be ordered separately.

Casting Alloy: 356-T6 Aluminum

ALUMINUM • 345 - 500kV

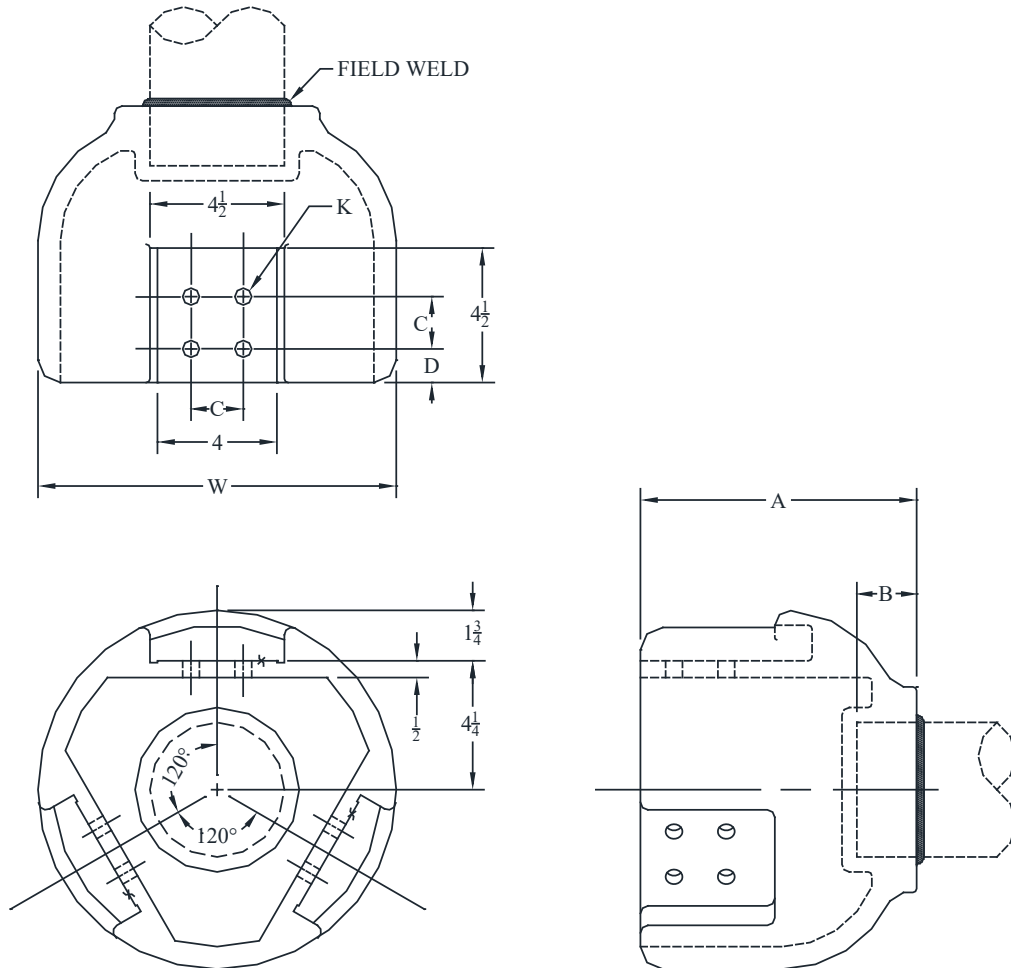

CATALOG NUMBER	PIPE SIZE (NPS)	DIMENSIONS - INCHES					
		A	B	C	D	K	W
WSTC3-62-4B	3	9-1/4	2	1-3/4	1-1/8	9/16	12
WSTC3-63-4B	3-1/2	9-1/4	2	1-3/4	1-1/8	9/16	12
WSTC3-64-4B	4	9-1/4	2	1-3/4	1-1/8	9/16	12
WSTC3-67-4B	5	11-1/4	2	1-3/4	1-1/8	9/16	12
WSTC3-69-4B	6	9-3/8	2	1-3/4	1-1/8	9/16	12-1/2

SEFCOR

EHV COUPLERS

TYPE WXCCF

Welded Expansion Couple
Pipe to Pipe

Casting Alloy: 356-T6 Aluminum
Alignment Guide: 6061-T6 Aluminum
Flexible Elements: Class A Stranded Cable

ALUMINUM • 345kV

Type WXCCF is self-shielding at voltages through 345kV by the flexible elements, which serve as corona rings.

Bus length/temperature limits: To obtain temperature range that can be accommodated (°F), divide "X-factor" by total bus length (both sides) in feet. To obtain maximum total bus length-divide "X-factor" by required temperature range (°F).

Bus lengths are to nearest fixed support.

Suffix (H) denotes SCH 80 pipe.

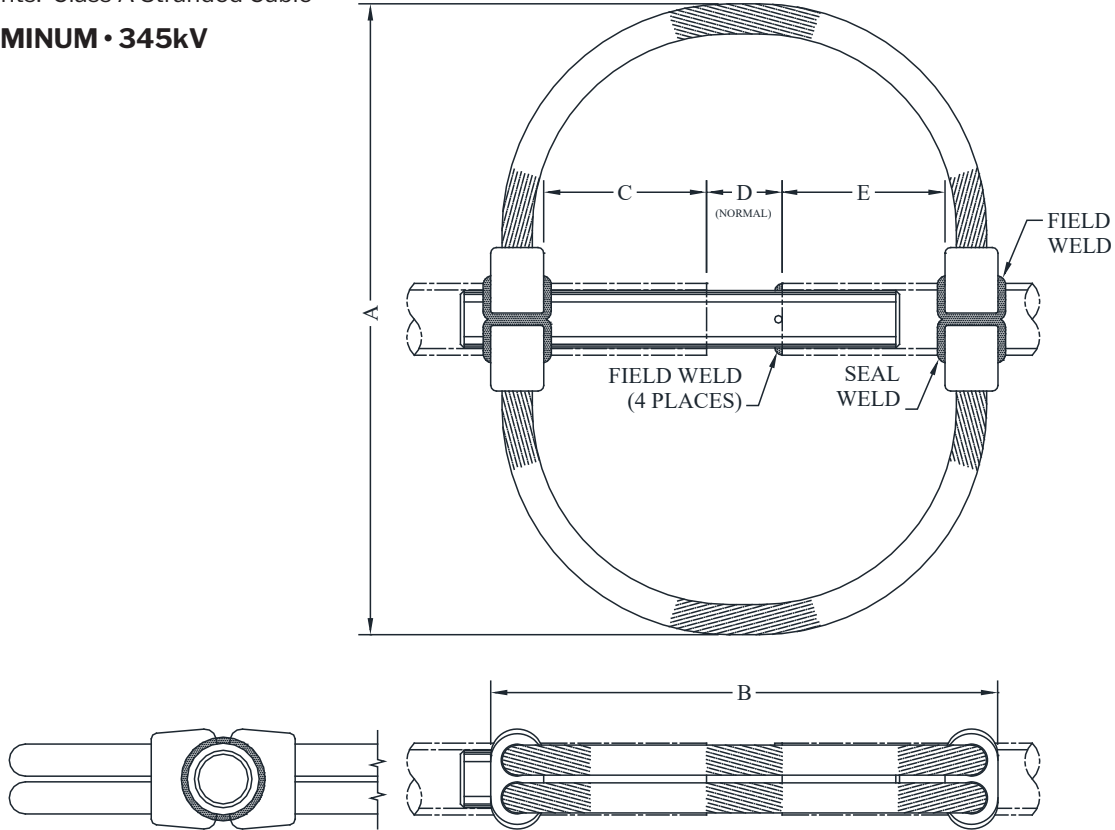

CATALOG NUMBER	PIPE SIZE (NPS)	X-FACTOR	DIMENSION - INCHES				
			*A	*B	C	D	E
WXCCF-6060	2-1/2" SCH 40	26042	28	20-3/4	7	3	6
WXCCF-6060H	2-1/2" SCH 80	26042	28	20-3/4	7	3	6
WXCCF-6262	3" SCH 40	26042	28	23-3/4	7	3	6
WXCCF-6262H	3" SCH 80	26042	28	23-3/4	7	3	6
WXCCF-6363	3-1/2" SCH 40	32552	27	23	7-1/2	3-1/2	7
WXCCF-6363H	3-1/2" SCH 80	32552	27	23	7-1/2	3-1/2	7
WXCCF-6464	4" SCH 40	32552	30	23-1/2	7-1/2	3-1/2	7
WXCCF-6464H	4" SCH 80	32552	30	23-1/2	7-1/2	3-1/2	7
WXCCF-6767	5" SCH 40	39062	28	24	8	3-3/4	7-3/4
WXCCF-6767H	5" SCH 80	39062	28	24	8	3-3/4	7-3/4
WXCCF-6969	6" SCH 40	39062	36	21	8-1/4	4	8-1/4
WXCCF-6969H	6" SCH 80	39062	36	21	8-1/4	4	8-1/4

*Normal

SEFCOR

EHV COUPLERS

TYPE WXCF-CS

Welded Expansion Coupler
Pipe to Pipe

Casting Alloy: 356-T6 Aluminum
Flexible Elements: 1100-0 Aluminum
Shield rings: 6063-T6 Aluminum
Alignment Guide: 6061-T6 Aluminum

ALUMINUM • 345 - 500kV

Type WXCF-CS1 and CS2 weld expansion couplers provide corona-free service at 345kV and 500kV respectively. Maximum temperature range is obtained by dividing the "X-factor" by the total bus length (feet) between fixed supports. Maximum bus length between fixed supports is obtained by dividing the "X-factor" by the required temperature range (°F). Dimensions are the same for both 345 and 500kV except for "T" dimension.

345kV: T = 1.7 in.

500kV: T = 2.4 in.

It is good practice to install this type of fitting as close to a bus support as the station design allows. (H) suffix denotes SCH 80 pipe.

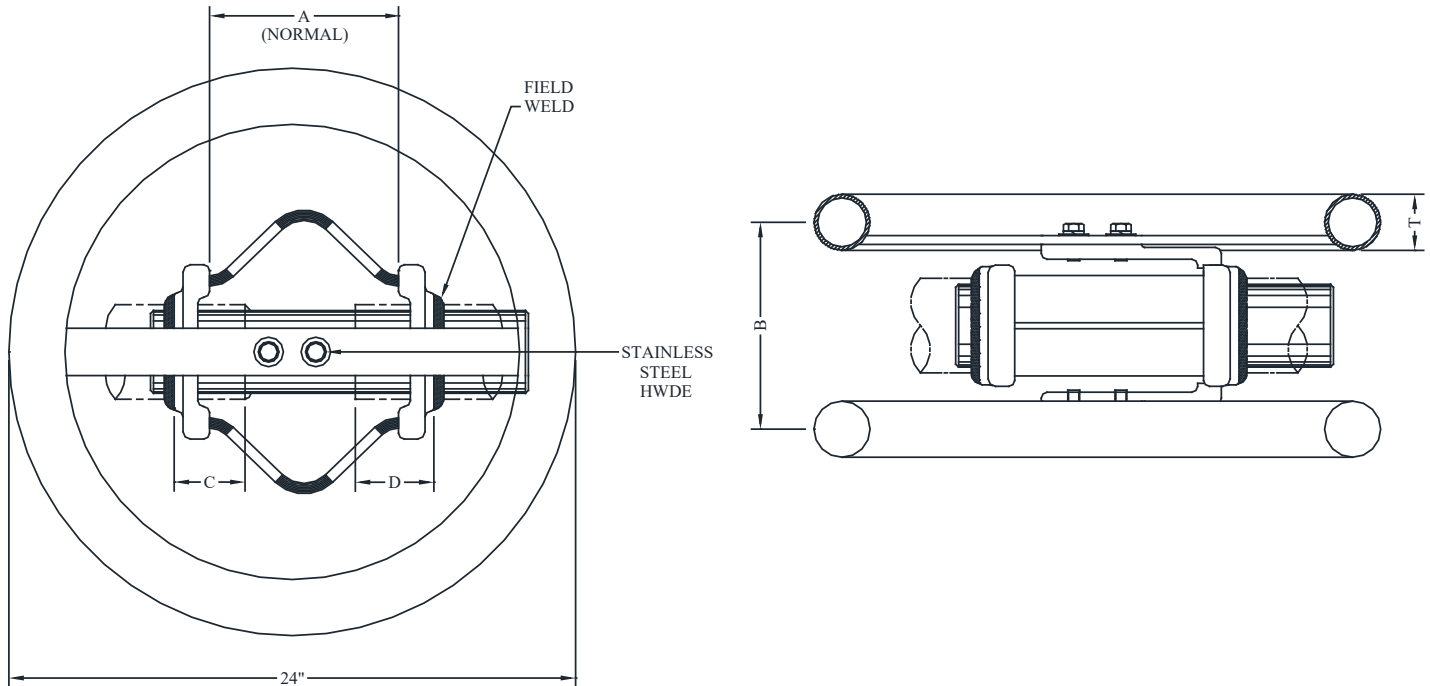

CATALOG NUMBER		PIPE SIZE (NPS)	X-FACTOR	DIMENSIONS - INCHES			
345kV	500kV			A	B	C	D
WXCF-6262-CS1	WXCF-6262-CS2	3" SCH 40	32552	8	8	5-1/2	3
WXCF-6262H-CS1	WXCF-6262H-CS2	3" SCH 80	32552				
WXCF-6363-CS1	WXCF-6363-CS2	3-1/2" SCH 40	39062	8	8	3	5-1/2
WXCF-6363H-CS1	WXCF-6363H-CS2	3-1/2" SCH 80	39062				
WXCF-6464-CS1	WXCF-6464-CS2	4" SCH 40	39062	9	8-1/2	3-1/8	5-5/8
WXCF-6464H-CS1	WXCF-6464H-CS2	4" SCH 80	39062				
WXCF-6767-CS1	WXCF-6767-CS2	5" SCH 40	39062	10	10-3/8	8	4
WXCF-6767H-CS1	WXCF-6767H-CS2	5" SCH 80	39062				
WXCF-6969-CS1	WXCF-6969-CS2	6" SCH 40	39062	11-1/2	10-3/4	4	8-1/2
WXCF-6969H-CS1	WXCF-6969H-CS2	6" SCH 80	39062				

ALUMINUM, BRONZE & EHV END CAPS & CORONA BELLS



WEB



WEPC



DP-AL



DPS-AL



DP-BR



DPS-BR



ABIR

ALUMINUM END CAPS & CORONA BELLS

TYPE DP-AL

Drive On - Internal
Eng Plug

Casting Alloy: 356-F Aluminum

Internal aluminum end plug for reducing electrostatic loss and enclosing NPS SCH 40 or SCH 80 pipe ends.
Plug is designed for drive-in fit with tapered internal fingers.
Consult manufacturer for further details or unlisted applications.
Add (H) to conductor code for SCH 80 pipe.
Example: DP-39H-AL

CATALOG NUMBER		CONDUCTOR SIZE (NPS)	THICKNESS (INCHES) T	WEIGHT (POUNDS)
NPS SCH 40	NPS SCH 80			
DP-39-AL	DP-39H-AL	1	3/8	0.20
DP-49-AL	DP-49H-AL	1-1/4	3/8	0.30
DP-53-AL	DP-53H-AL	1-1/2	7/16	0.20
DP-58-AL	DP-58H-AL	2	1/2	0.30
DP-60-AL	DP-60H-AL	2-1/2	5/8	0.50
DP-62-AL	DP-62H-AL	3	13/16	0.70
DP-63-AL	DP-63H-AL	3-1/2	13/16	0.80
DP-64-AL	DP-64H-AL	4	7/8	1.10
DP-67-AL	DP-67H-AL	5	1-1/4	2.15
DP-69-AL	DP-69H-AL	6	1-1/2	2.50

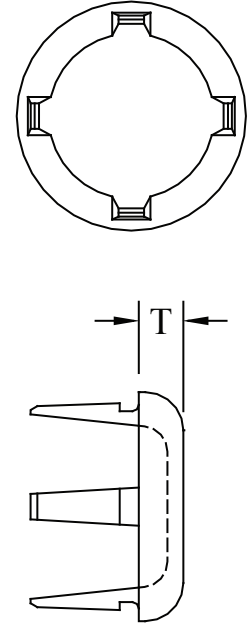

TYPE DPS-AL

Drive On - Internal
Eng Plug

Casting Alloy: 356-F Aluminum

Internal aluminum end plug for reducing electrostatic loss and enclosing NPS SCH 40 or SCH 80 pipe ends.
Compared to the DP- series, the exposed portion of the DPS- series is reduced for use with expansion bus supports and bolted terminals.
The end cap is designed for a drive-in fit with tapered internal fingers.
Consult manufacturer for further details or unlisted applications.
Add (H) to conductor code for SCH 80 pipe. Example: DPS-62H-AL

CATALOG NUMBER		CONDUCTOR SIZE (NPS)	THICKNESS (INCHES) T	WEIGHT (POUNDS)
NPS SCH 40	NPS SCH 80			
DPS-39-AL	DPS-39H-AL	1	1/4	0.25
DPS-49-AL	DPS-49H-AL	1-1/4	1/4	0.25
DPS-53-AL	DPS-53H-AL	1-1/2	3/8	0.25
DPS-58-AL	DPS-58H-AL	2	3/8	0.30
DPS-60-AL	DPS-60H-AL	2-1/2	3/8	0.50
DPS-62-AL	DPS-62H-AL	3	3/8	0.50
DPS-63-AL	DPS-63H-AL	3-1/2	3/8	0.60
DPS-64-AL	DPS-64H-AL	4	3/8	0.70
DPS-67-AL	DPS-67H-AL	5	3/8	1.00
DPS-69-AL	DPS-69H-AL	6	3/8	1.40

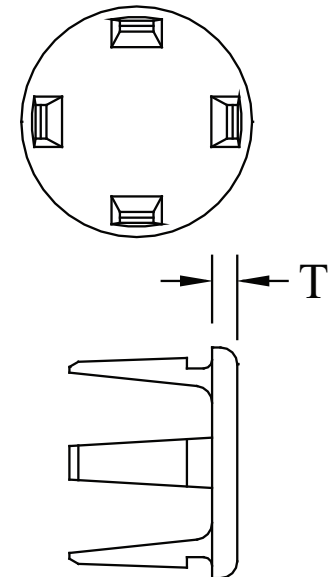

ALUMINUM END CAPS & CORONA BELLS

TYPE WEB

Internal - Welded
End Cap

Welded aluminum alloy internal end plug for pipe.
Consult manufacturer for further details or unlisted applications.
Add suffix (H) for SCH 80 pipe.
Example: WEB-58H

Casting Alloy: 356-F Aluminum

CATALOG NUMBER		CONDUCTOR SIZE (NPS)	THICKNESS (INCHES)	WEIGHT (POUNDS)
NPS SCH 40	NPS SCH 80		T	
WEB-49	WEB-49H	1-1/4	3/8	0.30
WEB-53	WEB-53H	1-1/2	3/8	0.30
WEB-58	WEB-58H	2	3/8	0.30
WEB-60	WEB-60H	2-1/2	1/2	0.50
WEB-62	WEB-62H	3	1/2	0.40
WEB-63	WEB-63H	3-1/2	1/2	0.50
WEB-64	WEB-64H	4	9/16	0.65
WEB-67	WEB-67H	5	5/8	1.25
WEB-69	WEB-69H	6	3/8	2.00
WEB-71	WEB-71H	8	3/8	3.50

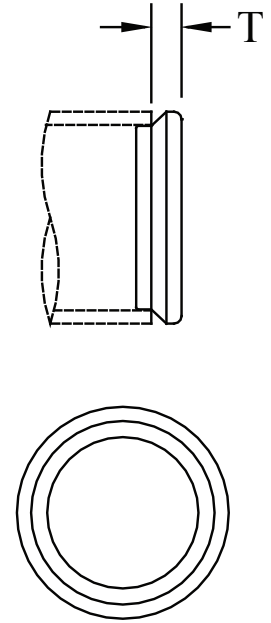

TYPE ABIR

Internal - Welded
End Bell

Welded aluminum internal fit corona bell for 15-230 KV range pipe.

Add suffix (H) for SCH 80 pipe.
Example: ABIR-39H

Casting Alloy: 356-T6 Aluminum

CATALOG NUMBER	CONDUCTOR SIZE (NPS)
ABIR-39	1
ABIR-49	1-1/4
ABIR-53	1-1/2
ABIR-58	2
ABIR-60	2-1/2
ABIR-62	3
ABIR-63	3-1/2
ABIR-64	4
ABIR-67	5
ABIR-69	6

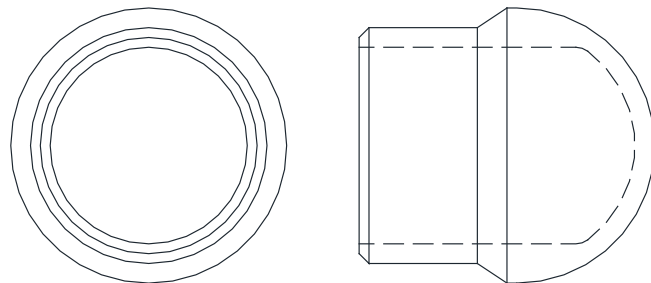

BRONZE END CAPS & CORONA BELLS

TYPE DP-BR

Drive On - Internal
End Plug

Internal bronze end plug for enclosing NPS SCH 40 or SCH 80 pipe ends. Plug is designed for drive-in fit with tapered internal fingers. Add (H) to conductor code for SCH 80 pipe. Example: DP-39H-BR.

Casting Alloy: Electrical Bronze

CATALOG NUMBER		CONDUCTOR SIZE (NPS)	THICKNESS (INCHES) T	WEIGHT (POUNDS)
NPS SCH 40	NPS SCH 80			
DP-39-BR	DP-39H-BR	1	3/8	0.62
DP-49-BR	DP-49H-BR	1-1/4	3/8	0.92
DP-53-BR	DP-53H-BR	1-1/2	7/16	0.75
DP-58-BR	DP-58H-BR	2	1/2	0.90
DP-60-BR	DP-60H-BR	2-1/2	5/8	1.625
DP-62-BR	DP-62H-BR	3	13/16	3.25
DP-63-BR	DP-63H-BR	3-1/2	13/16	4.00
DP-64-BR	DP-64H-BR	4	7/8	3.25
DP-67-BR	DP-67H-BR	5	1-1/4	6.90
DP-69-BR	DP-69H-BR	6	1-1/2	8.125

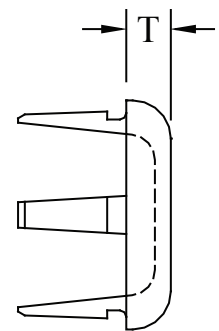
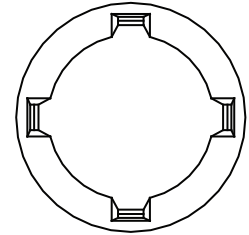

TYPE DPS-BR

Drive On - Internal
End Plug

Internal bronze end plug for reducing electrostatic loss and enclosing NPS SCH 40 or SCH 80 pipe ends. Compared to the DP series, the exposed portion of the DPS series is reduced for use with expansion bus supports and bolted terminals. The end cap is designed for a drive-in fit with tapered internal fingers. Consult manufacturer for further details or unlisted applications. Add (H) to conductor code for SCH 80 pipe. Example: DPS-62H-BR

Casting Alloy: Electrical Bronze

CATALOG NUMBER		CONDUCTOR SIZE (NPS)	THICKNESS (INCHES) T	WEIGHT (POUNDS)
NPS SCH 40	NPS SCH 80			
DPS-39-BR	DPS-39H-BR	1	1/4	0.25
DPS-49-BR	DPS-49H-BR	1-1/4	1/4	0.25
DPS-53-BR	DPS-53H-BR	1-1/2	3/8	0.25
DPS-58-BR	DPS-58H-BR	2	3/8	0.30
DPS-60-BR	DPS-60H-BR	2-1/2	3/8	0.50
DPS-62-BR	DPS-62H-BR	3	3/8	0.50
DPS-63-BR	DPS-63H-BR	3-1/2	3/8	0.60
DPS-64-BR	DPS-64H-BR	4	3/8	0.70
DPS-67-BR	DPS-67H-BR	5	3/8	1.00
DPS-69-BR	DPS-69H-BR	6	3/8	1.40

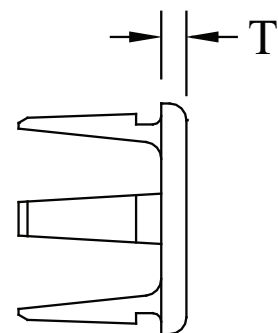
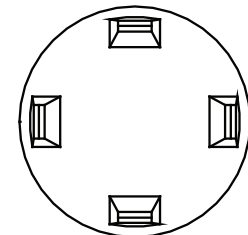

EHV END CAPS & CORONA BELLS

TYPE WEPC

Weld External
End Bell

Type WEPC is external weld in-bell for 345 or 500kV.
Sphere surfaces are factory-finished to assure corona-free service.

Casting Alloy: 356-T6 Aluminum

ALUMINUM • 345 - 500kV

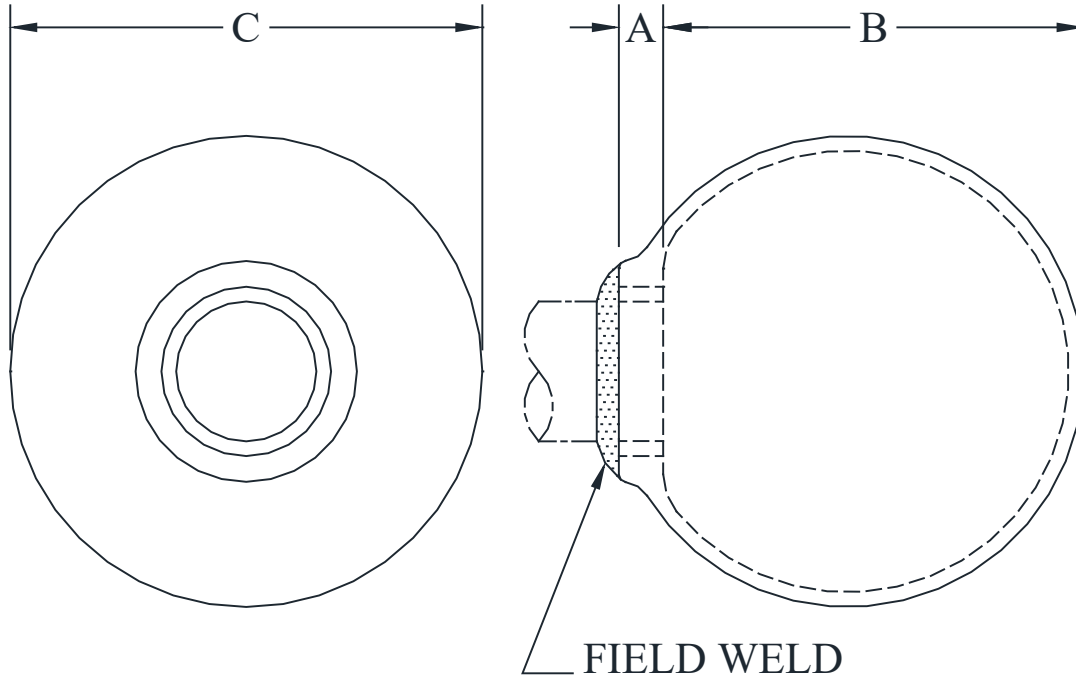

CATALOG NUMBER	PIPE SIZE (NPS)	MAX KV	DIMENSIONS - INCHES		
			A	B	C
WEPC-60-8	2-1/2	345	3/4	7-1/8	8
WEPC-60-12		500	2	11-5/8	12
WEPC-62-8	3	345	3/4	7	8
WEPC-62-12		500	1-1/4	11-3/4	12
WEPC-63-8	3-1/2	345	3/4	6-1/2	8
WEPC-63-12		500	1-1/8	11-11/16	12
WEPC-64-8	4	345	3/4	6-1/2	8
WEPC-64-12		500	1	11-5/8	12
WEPC-67-8	5	345	7/8	6-1/8	8
WEPC-67-12		500	1-5/8	11	12
WEPC-69-8	6	345	2-1/2	2-3/8	8
WEPC-69-12		500	1-5/8	10-7/8	12

ALUMINUM, BRONZE & EHV CABLE SPACERS



ASPC



ASPC-4B



ASPCHV



ASBC3



ASBC4

ALUMINUM CABLE SPACERS

TYPE ASPC

Straight Bolted
Cable Spacer

Casting Alloy: 356-T6 Aluminum
Clamping Hardware: Aluminum Alloy

Parallel cable spacer for maintaining cable clearance and preventing loose cable damage.

Consult manufacturer for further details or unlisted applications.

L=center line cable spacing.

Ex.: ASPC-20-8

For cable spacer with terminal add suffix - 2B,-4A, or -4B.

Ex: ASPC-20-8-4A.

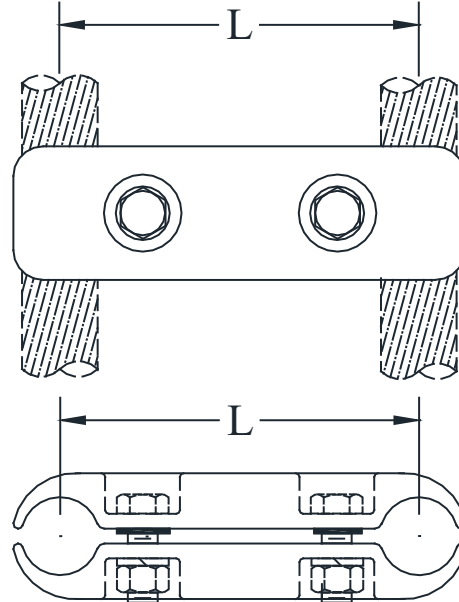

CATALOG NUMBER	CONDUCTOR RANGE	
	AAC	ACSR
ASPC-20-(L)	336 - 600 MCM	336 - 477 MCM
ASPC-22-(L)	556.5 MCM	477 MCM
ASPC-24-(L)	636 - 750 MCM	556.5 MCM
ASPC-29-(L)	750 - 795 MCM	636 - 666 MCM
ASPC-32-(L)	795 - 900 MCM	666 - 715 MCM
ASPC-34-(L)	954 - 1000 MCM	795 MCM
ASPC-35-(L)	954 - 1033 MCM	900 - 954 MCM
ASPC-36-(L)	954 - 1113 MCM	900 - 1033 MCM
ASPC-38-(L)	1113 - 1272 MCM	1033 - 1192.5 MCM
ASPC-39-(L)	1113 - 1272 MCM	954 - 1192.5 MCM
ASPC-41-(L)	1272 - 1431 MCM	1192 - 1272 MCM
ASPC-43-(L)	1431 - 1590 MCM	1272 - 1431 MCM
ASPC-46-(L)	1590 - 1750 MCM	1510 - 1590 MCM
ASPC-49-(L)	2000 MCM	1780 MCM
ASPC-51-(L)	2250 - 2500 MCM	2156 - 2312 MCM
ASPC-54-(L)	3000 MCM	---
ASPC-56-(L)	3500 MCM	---
ASPC-57-(L)	3640 MCM	---

BRONZE CABLE SPACERS

TYPE ASPC-BR

Parallel Spacer
Cable to Cable

Bronze parallel cable spacer for maintaining copper cable clearance.
Consult manufacturer for further details or unlisted applications.
L = Center Line Cable Spacing
Example: ASPC-20-4-BR

Casting Alloy: Electrical Bronze
Clamping Hardware: Silicon Bronze

CATALOG NUMBER	CONDUCTOR RANGE
ASPC-20-(L)-BR	350 - 500 MCM
ASPC-24-(L)-BR	650 - 750 MCM
ASPC-27-(L)-BR	750 MCM
ASPC-34-(L)-BR	950 - 1000 MCM
ASPC-35-(L)-BR	800 - 1000 MCM
ASPC-41-(L)-BR	1250 - 1500 MCM
ASPC-43-(L)-BR	1500 MCM
ASPC-49-(L)-BR	2000 MCM

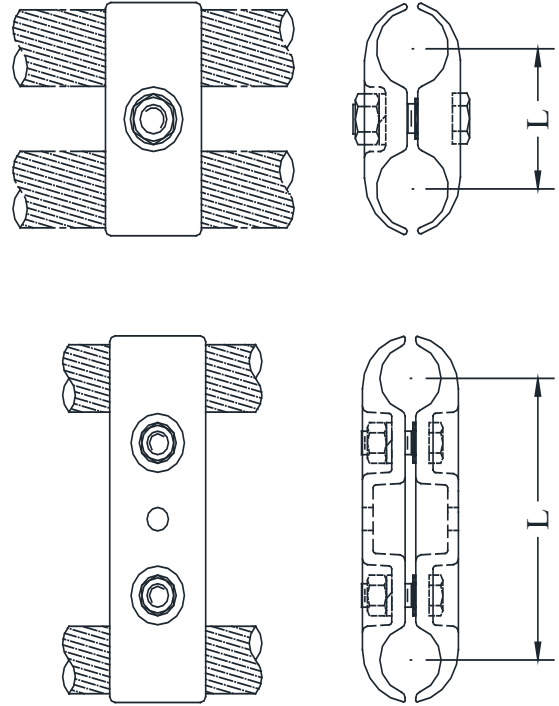

TYPE CSPC

Parallel Spacer
Cable to Cable

Bronze parallel cable spacer for maintaining copper cable clearance.
Consult manufacturer for further details or unlisted applications.
L = Center Line Cable Spacing
Example: CSPC-20-4

Casting Alloy: Electrical Bronze
Clamping Hardware: Silicon Bronze

CATALOG NUMBER	CONDUCTOR RANGE	DIMENSIONS (INCHES)	WEIGHT (POUNDS)
		L	
CSPC-20-(L)	300 - 500 MCM	4	3.45
CSPC-20-(L)	500 MCM	6	3.15
CSPC-28-(L)	500 - 800 MCM	4	5.75
CSPC-28-(L)	500 - 800 MCM	6	6.45
CSPC-34-(L)	750-1000 MCM	6	5.55
CSPC-34-(L)	750-1000 MCM	8	5.85
CSPC-1134-(L)	4/0 STR - 1000 MCM	3	3.70
CSPC-1134-(L)	4/0 STR - 1000 MCM	4	3.75
CSPC-1134-(L)	4/0 STR - 1000 MCM	6	6.10

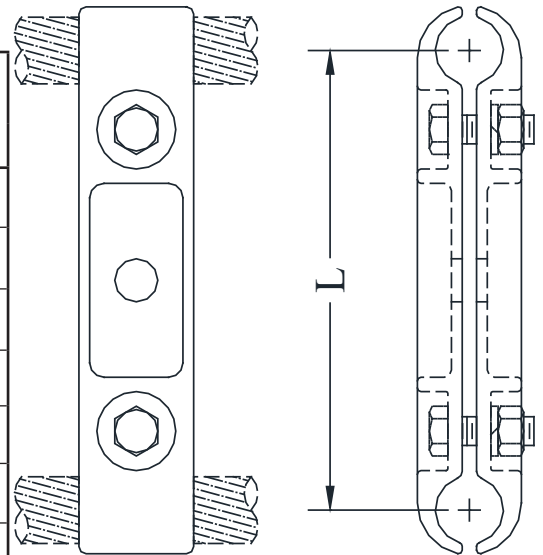

EHV CABLE SPACERS

TYPE ASPC

Bolted Spacer
Two Cables

Casting Alloy: 356-T6 Aluminum
Clamping Hardware: Aluminum Alloy

ALUMINUM • 345kV

Type ASPC is designed for corona-free service at 345kV. The simple two piece-construction maintains a specified sub-conductor spacing. Replace (L) with desired dimension to specify the sub-conductor spacing. Ex.: ASPC-43-8 for 8" spacing for 1590 AAC.

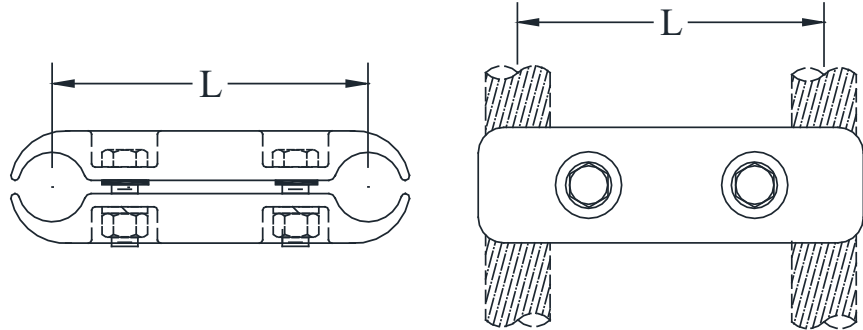

CATALOG NUMBER	CONDUCTOR RANGE	
	AAC	ACSR
ASPC-34-(L)	954 - 1000 MCM	795 MCM
ASPC-35-(L)	954 - 1033 MCM	900-954 MCM
ASPC-36-(L)	1033 - 1113 MCM	954 - 1033 MCM
ASPC-38-(L)	1113 - 1272 MCM	954 - 1192.5 (45/7) MCM
ASPC-39-(L)	1113 - 1272 MCM	954 - 1192.5 (45/7) MCM
ASPC-41-(L)	1272 - 1431 MCM	1192 - 1272 MCM
ASPC-43-(L)	1431 - 1590 MCM	1272 - 1431 MCM
ASPC-46-(L)	1750 MCM	1510 - 1590 MCM
ASPC-49-(L)	2000 MCM	1780 MCM
ASPC-51-(L)	2250 - 2500 MCM	2156- 2312 MCM
ASPC-54-(L)	3000 MCM	---
ASPC-56-(L)	3500 MCM	---
ASPC-57-(L)	3640 MCM	---

TYPE ASPC-4B

Bolted Spacer With Tee Bar
Two Cables to Flat Pad

Casting Alloy: 356-T6 Aluminum
Clamping Hardware: Aluminum Alloy

Note: See hardware shield AA-1094.

Type ASPC above is available with bar tap as shown. Specify by adding suffix "-4B" to the appropriate catalog number. Example: ASPC-38-6-4B

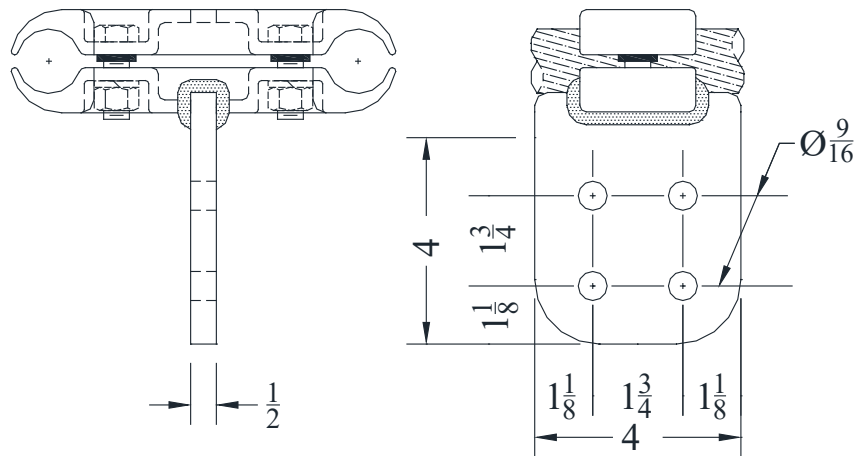

EHV CABLE SPACERS

TYPE ASPCHV

Bolted Spacer
Two Cables

Casting Alloy: 356-T6 Aluminum
Spacer Pipe: 6061-T6 Aluminum
Clamping Hardware: Aluminum Alloy

Type ASPCHV rigid cable spacer is designed for corona-free service within the voltage limitations of the conductor bundle. It is for use on bundled-conductor station bus work, not for transmission lines.

A grounding stirrup can be incorporated in the spacer member as shown, when required.

Other sub-conductor spacings may be available.

Contact manufacturer with spacing specifications.

ALUMINUM • 345 - 500kV

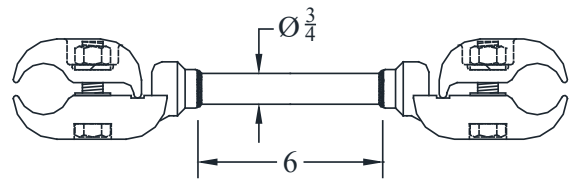
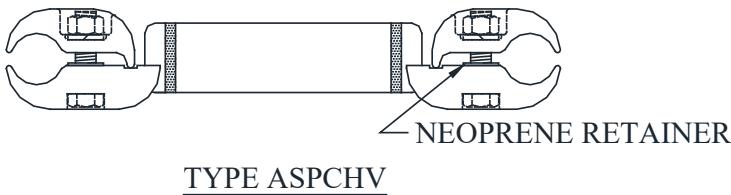
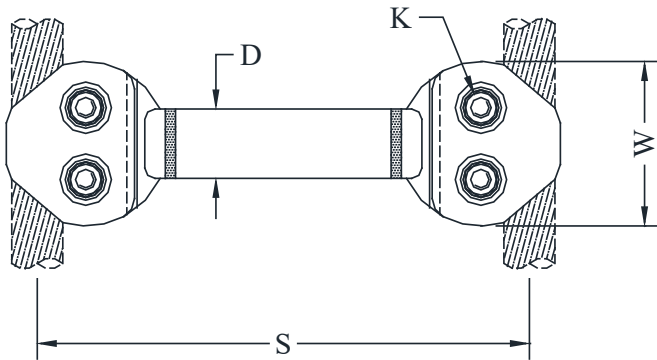

WITH GROUNDING STIRRUP
ADD SUFFIX -ST TO CATALOG NUMBERS BELOW

CATALOG NUMBER	CONDUCTOR RANGE		DIMENSIONS - INCHES			
	AAC	ACSR	S	W	D	K
ASPCHV-32-12	795 - 900	715 - 795	12	4	1.32	1/2
ASPCHV-35-12	954 - 1033.5	795 - 954	12	4	1.32	1/2
ASPCHV-38-12	1113 - 1192.5	1033.5 - 1113	12	4	1.66	1/2
ASPCHV-41-12	1272 - 1431	1192 - 1272	12	4	1.66	1/2
ASPCHV-43-12	1510 - 1600	1351 - 1451	12	4	1.66	1/2
ASPCHV-46-12	1750	1510 - 1590	12	4	1.66	1/2
ASPCHV-46-18	1750	1510 - 1590	18	4	1.66	1/2
ASPCHV-48-18	1933 - 2031	1780	18	4	1.66	1/2
ASPCHV-51-18	2250 - 2500	2032 - 2312	18	4-3/8	1.66	5/8
ASPCHV-54-18	2750 - 3000	2515	18	4-3/8	1.66	5/8

EHV CABLE SPACERS

TYPE ASBC3 & ASBC4
 Bolted Cable Spacers
 3 & 4 Cables

Type ASBC3 and ASBC4 are rigid spacers, designed for corona-free service at 345 and 500kV. They are suitable for use on bundled-conductor station bus work. Not recommended for overhead transmission lines.

Casting Alloy: 356-T6 Aluminum
 Clamping Hardware: Stainless Steel

ALUMINUM • 345 - 500kV

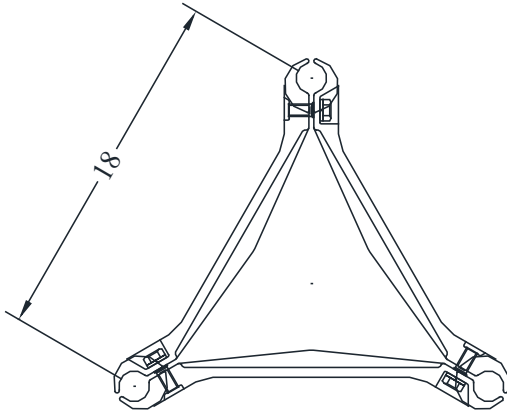

TYPE ASBC3

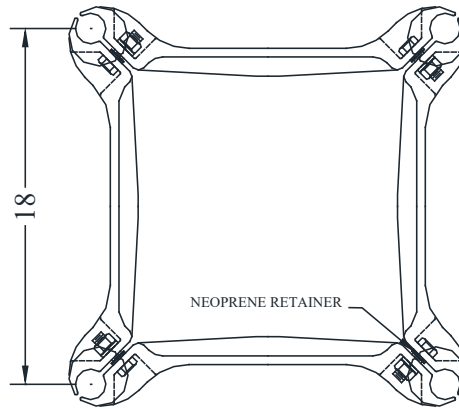

TYPE ASBC4

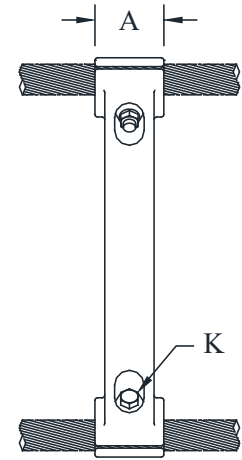

CATALOG NUMBER		CONDUCTOR SIZE (MCM)		DIMENSIONS - INCHES	
TYPE ASBC3	TYPE ASBC4	AAC	ACSR	A	K
ASBC3-36	ASBC4-36	-----	954	3	5/8
ASBC3-37	ASBC4-37	1033.50-1192 MCM	954 - 1033 MCM	3	5/8
ASBC3-39	ASBC4-39	1272 MCM	1113 MCM	3	5/8
ASBC3-41	ASBC4-41	1272 - 1431 MCM	1192 - 1272 MCM	3	5/8
ASBC3-46	ASBC4-46	1590 - 1750 MCM	1510 - 1590 MCM	3	5/8
ASBC3-51	ASBC4-51	2250 MCM	2034 - 2156 MCM	3-1/2	5/8
ASBC3-52	ASBC4-52	2500 MCM	2312 - 2515 MCM	3-1/2	5/8

SPECIALTY DESIGN STUD CONNECTORS

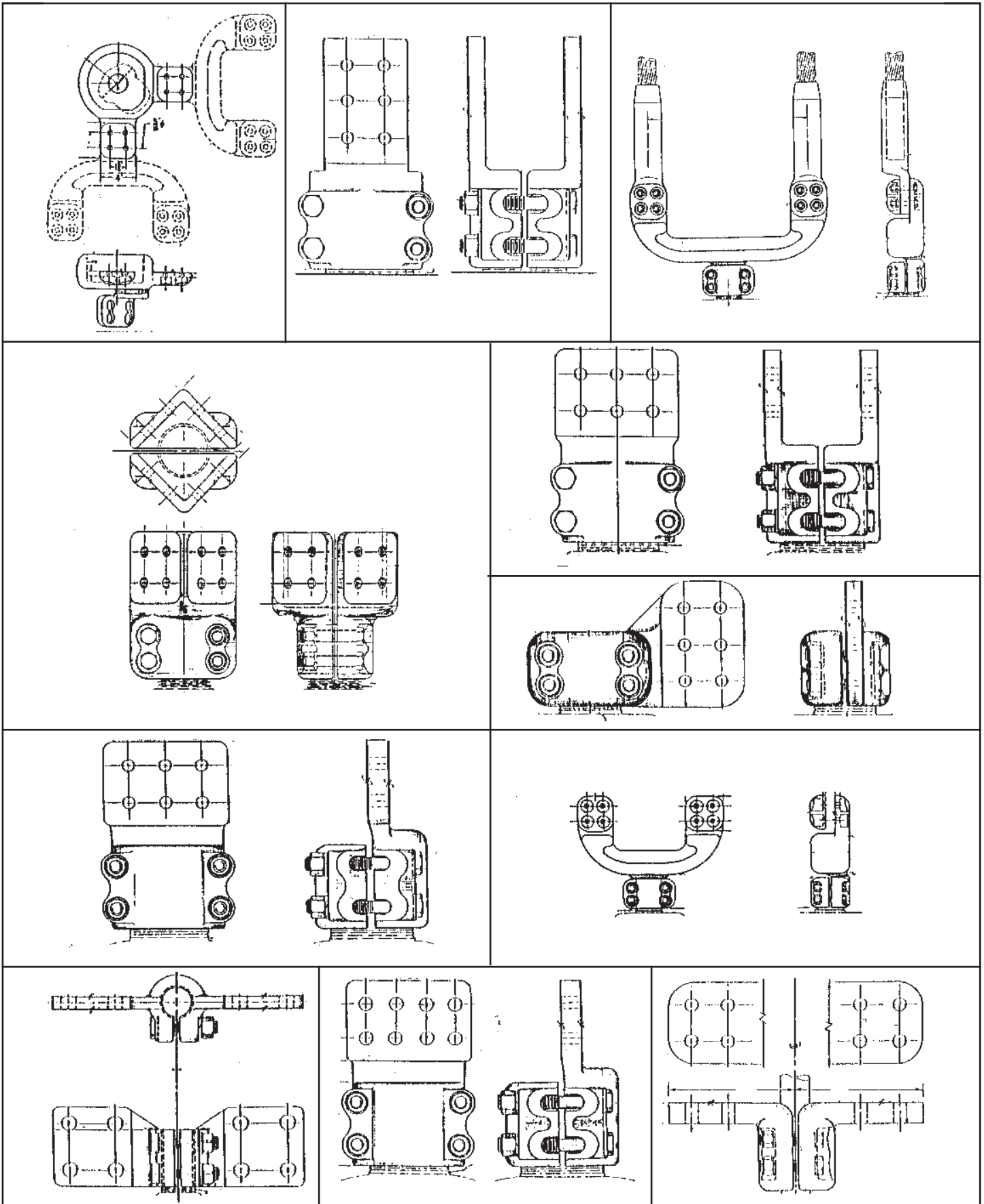

*CONTACT FACTORY FOR YOUR SPECIALTY STUD-CONNECTOR REQUIREMENTS

SEFCOR

ALUMINUM STUD CONNECTORS



ASFF



ASCC



ASTT



ASTR



ASXTR



ASFFT

SEFCOR aluminum stud connectors are cast from certified aluminum alloy 356 ingot. The castings are heat treated to T6 temper. Only high quality electrical aluminum per ASTM-B26 is utilized to insure the current-carrying as well as mechanical strength. Alloy 356 is not susceptible to stress corrosion.

Metric options available for smooth and threaded stud connectors. Contact the factory for more details.

This section is arranged in the following sequence for the convenience of the user:

**STUD TO FLAT PAD
STUD TO CABLE
STUD TO PIPE**

OPTIONS

A suffix added to a catalog number denotes a variation or option made to the standard cataloged item. The suffixes listed below display the various options available with SEFCOR aluminum stud connectors. Consult manufacturer for further details, unlisted and/or special applications.

- A () Factory-set angle, (i.e.; A45, provides for a 45° angle)
- B Flexible braid elements instead of laminations
- CCN Supplied with contact nuts
- CNS Supplied with cap nuts
- FF Finish both sides of contact pad when not customary to do so
- GS Galvanized steel hardware in lieu of standard hardware
- H Heavy (extra thickness contact pad)
- SP Special requirement, refer to factory
- SS Stainless steel hardware instead of standard hardware
- TØ Smooth stud bore - no threads
- T () Special stud threads, (i.e.; T14, provides 14 threads per inch)

ALUMINUM STUD CONNECTORS

TYPE ASCC

Bolted
Stud to Cable

All-aluminum stud connector for stud to aluminum cable.
Connector threads are factory-coated with contact sealant.
Metric options available for smooth and threaded stud connectors.
Contact the factory for more details.

Casting Alloy: 356-T6 Aluminum
Clamping Hardware: Aluminum Alloy
Options: See Page 195

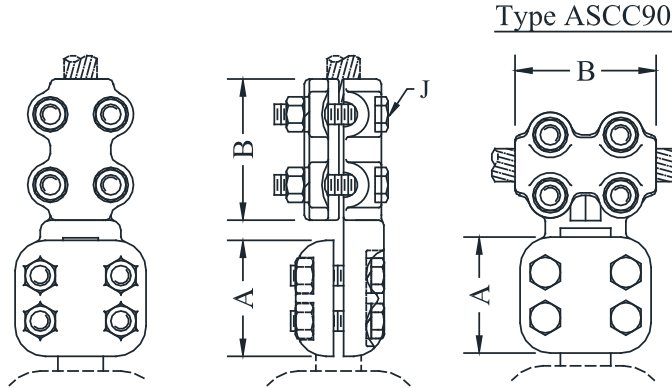

CATALOG NUMBER	STUD IN./THD.	CONDUCTOR RANGE		DIMENSIONS - INCHES			WEIGHT (POUNDS)
		AAC	ACSR	A	B	J	
ASCC-1813	3/4 - 16	#4 W - 266 MCM	#4 - 4/0	CONTACT FACTORY FOR DETAILS			
ASCC-1820		4/0 - 500 MCM	4/0 - 397.5 MCM	2-3/4	3-1/2	1/2	2.55
ASCC-2713	1 - 14	#4 W - 266 MCM	#4 - 4/0	CONTACT FACTORY FOR DETAILS			
ASCC-2720		4/0 - 500 MCM	4/0 - 397.5 MCM	2-3/4	3-1/2	1/2	3.00
ASCC-2724		350 - 650 MCM	336 - 556 MCM	CONTACT FACTORY FOR DETAILS			
ASCC-3313	1-1/8 - 12	#4 W - 266 MCM	#4 - 4/0	CONTACT FACTORY FOR DETAILS			
ASCC-3320		4/0 - 500 MCM	4/0 - 397.5 MCM	2-3/4	3-1/2	1/2	2.55
ASCC-3324		350 - 650 MCM	336 - 556 MCM	CONTACT FACTORY FOR DETAILS			
ASCC-3334		550 - 1000 MCM	477 - 795 MCM	2-7/8	4	1/2	3.05
ASCC-3620	1-1/4 - 12	4/0 - 500 MCM	4/0 - 397.5 MCM	2-7/8	3-1/2	1/2	2.55
ASCC-3624		350 - 650 MCM	336 - 556 MCM	2-7/8	4	1/2	2.70
ASCC-3634		550 - 1000 MCM	477 - 795 MCM	2-7/8	4	1/2	4.10
ASCC-3639		874 - 1272 MCM	715 - 1113 MCM	CONTACT FACTORY FOR DETAILS			
ASCC-4420	1-1/2 - 12	4/0 - 500 MCM	4/0 - 397.5 MCM	2-7/8	3-1/2	1/2	3.05
ASCC-4424		350 - 650 MCM	336 - 556 MCM	2-7/8	4	1/2	3.30
ASCC-4434		550 - 1000 MCM	477 - 795 MCM	2-7/8	4	1/2	3.30
ASCC-4439		874 - 1272 MCM	715 - 1113 MCM	2-7/8	4-1/4	1/2	3.50
ASCC-4443		1250 - 1590 MCM	1113 - 1590 MCM	2-7/8	4-1/2	1/2	4.10
ASCC-5024	1-3/4 - 12	350 - 650 MCM	336 - 556 MCM	CONTACT FACTORY FOR DETAILS			
ASCC-5034		550 - 1000 MCM	477 - 795 MCM	2-7/16	4	1/2	3.70
ASCC-5039		874 - 1272 MCM	715 - 1113 MCM	CONTACT FACTORY FOR DETAILS			
ASCC-5043		1250 - 1590 MCM	1113 - 1431 MCM	2-7/16	4-1/2	1/2	4.20
ASCC-5424	2 - 12	350 - 650 MCM	336 - 556 MCM	2-7/16	4	1/2	3.90
ASCC-5434		550 - 1000 MCM	477 - 795 MCM	CONTACT FACTORY FOR DETAILS			
ASCC-5439		874 - 1300 MCM	715 - 1113 MCM				
ASCC-5443		1250 - 1590 MCM	1113 - 1431 MCM				

ALUMINUM STUD CONNECTORS

TYPE ASFF

Bolted

Stud to Flat Pad

All-aluminum stud connector for stud to flat NEMA pad.

Contact pad is finished on both sides.

Metric options available for smooth and threaded stud connectors.

Contact the factory for more details.

Casting Alloy: 356-T6 Aluminum
Clamping Hardware: Aluminum Alloy
Options: See Page 195

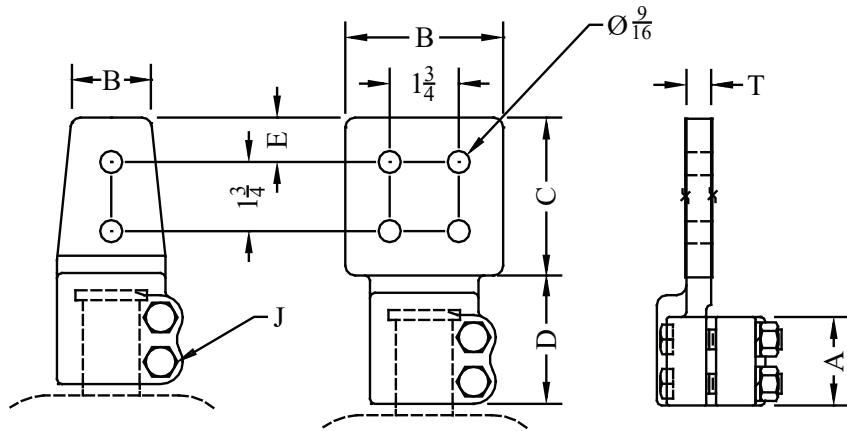

FIG. 1

FIG. 2

CATALOG NUMBER	STUD DIA./THD.	FIG. NO.	DIMENSIONS - INCHES							WEIGHT (POUNDS)	
			A	B	C	D	E	J	T		
ASFF-27-2B	1 - 14	1	2-1/4	2	3	3	3	5/8	1/2	7/16	0.70
ASFF-27-4A		2		3	3			5/8		7/16	1.00
ASFF-33-2B	1-1/8 - 12	1	2-1/4	2	3	3-1/8	3-1/8	5/8	1/2	1/2	0.90
ASFF-33-4A		2		3	3			5/8		1/2	1.20
ASFF-33-4B		2		4	4			1-1/8		3/4	1.40
ASFF-36-2B	1-1/4 - 12	1	2-1/4	2	3	3-1/8	3-1/8	5/8	1/2	3/4	1.00
ASFF-36-4A		2		3	3			5/8		3/4	1.30
ASFF-36-4B		2		4	4			1-1/8		3/4	1.80
ASFF-44-2B	1-1/2 - 12	1	2-1/4	2	3	3-1/8	3-1/8	5/8	1/2	1/2	1.00
ASFF-44-4A		2		3	3			5/8		1/2	1.30
ASFF-44-4B		2		4	4			1-1/8		1/2	1.80
ASFF-50-4A	1-3/4 - 12	2	2-1/4	3	3	3-1/4	3-1/4	5/8	1/2	5/8	1.70
ASFF-50-4B		2		4	4			1-1/8		9/16	2.10
ASFF-54-4A	2 - 12	2	2-1/4	3	3	3-1/4	3-1/4	5/8	1/2	5/8	2.20
ASFF-54-4B		2		4	4			1-1/8		5/8	2.70
ASFF-57-4A	2-1/4 - 12	2	2-3/8	3	3	3-3/8	3-3/8	5/8	1/2	5/8	2.50
ASFF-57-4B		2		4	4			1-1/8		5/8	2.80
ASFF-59-4A	2-1/2 - 12	2	2-1/4	3	3	3-1/4	3-1/4	5/8	1/2	5/8	2.60
ASFF-59-4B		2		4	4			1-1/8		5/8	2.90
ASFF-61-4A	3 - 12	2	3-1/4	3	3	4-3/8	4-3/8	5/8	5/8	3/4	4.10
ASFF-61-4B		2		4	4			1-1/8		3/4	4.40
ASFF-63-4B	4 - 12	2	3-1/4	4	4	4-3/8	4-3/8	1-1/8	5/8	1	5.60

SEFCOR

ALUMINUM STUD CONNECTORS

TYPE ASXR/ASXR2

Bolt-up Stud to
One or Two Cables

An alternative bolt-up type stud to one or two cables, with reversible caps for a wide range of cable, straight-on, or 90° to stud.

Bronze version also available see SXR/SXR2: PAGE 223

Casting Alloy: 356-T6 Aluminum
Clamping Hardware: Aluminum Alloy
Options: See Page 195

Metric options available for smooth and threaded stud connectors.
Contact the factory for more details.

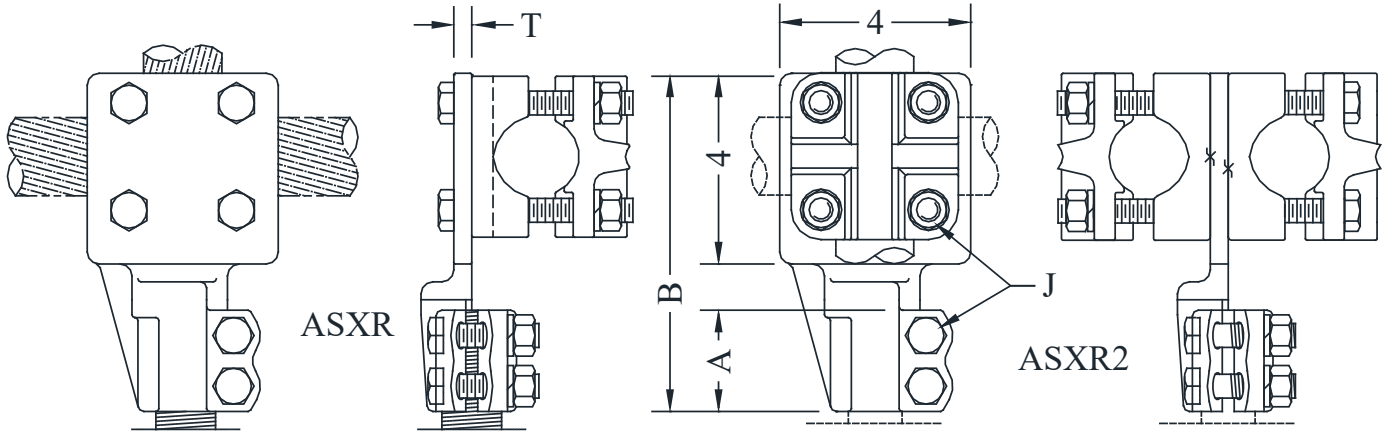

CATALOG NUMBER	STUD DIA./THD.	CONDUCTOR RANGE	DIMENSIONS - INCHES				WEIGHT (POUNDS)
			A	B	J	T	
ASXR-3348	1-1/8 - 12	#2 - 2000 MCM	2-1/4	7-1/8	1/2	3/4	3.60
ASXR2-3348		(2) #2 - 2000 MCM					6.55
ASXR-3648	1-1/4 - 12	#2 - 2000 MCM	2-1/4	7-1/8	1/2	3/4	3.60
ASXR2-3648		(2) #2 - 2000 MCM					6.40
ASXR-4448	1-1/2 - 12	#2 - 2000 MCM	2-1/4	7-1/8	1/2	1/2	3.75
ASXR2-4448		(2) #2 - 2000 MCM					6.45
ASXR-5048	1-3/4 - 12	#2 - 2000 MCM	2-1/4	7-1/4	1/2	9/16	5.10
ASXR2-5048		(2) #2 - 2000 MCM					6.85
ASXR-5448	2 - 12	#2 - 2000 MCM	2-1/4	7-1/4	1/2	5/8	5.30
ASXR2-5448		(2) #2 - 2000 MCM					7.30
ASXR-5748	2-1/4 - 12	#2 - 2000 MCM	2-3/8	7-3/8	1/2	5/8	4.60
ASXR2-5748		(2) #2 - 2000 MCM					7.60
ASXR-5948	2-1/2 - 12	#2 - 2000 MCM	3-1/2	8-1/4	1/2	1	10.25
ASXR2-5948		(2) #2 - 2000 MCM					12.00
ASXR-6148	3 - 12	#2 - 2000 MCM	3-1/2	8-1/4	1/2	1	9.40
ASXR2-6148		(2) #2 - 2000 MCM					12.00
ASXR-6348	4 - 12	#2 - 2000 MCM	4	9	1/2	1-1/4	13.60
ASXR2-6348		(2) #2 - 2000 MCM					15.35

ALUMINUM STUD CONNECTORS

TYPE ASTT

Bolted
Stud to Pipe

All-aluminum stud connector for stud to standard aluminum pipe.
For 90° connector, insert ASTT90 in place of ASTT in the table below.
Metric options available for smooth and threaded stud connectors.
Contact the factory for more details.

Casting Alloy: 356-T6 Aluminum
Clamping Hardware: Aluminum Alloy
Options: See Page 195

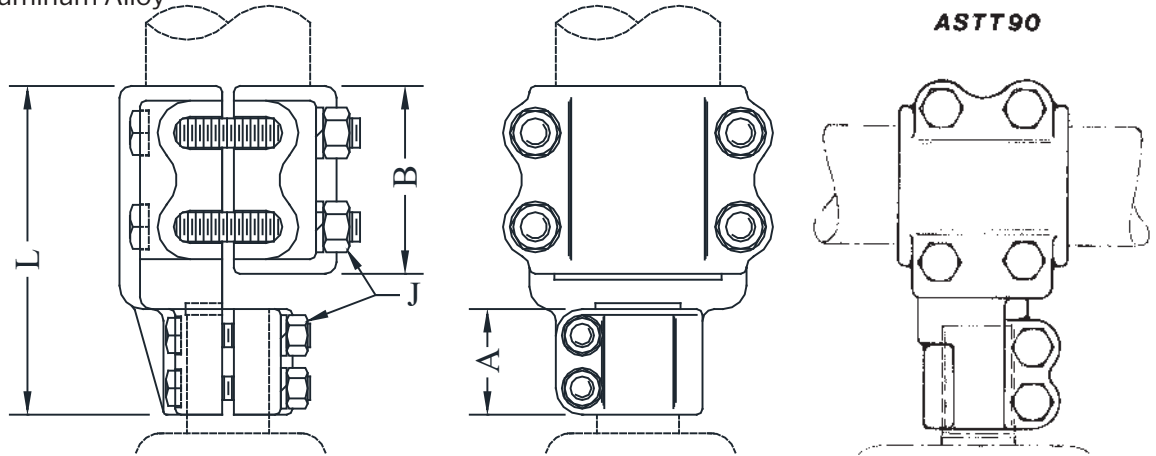

CATALOG NUMBER	STUD DIA./THD.	PIPE SIZE (NPS)	DIMENSIONS - INCHES				WEIGHT (POUNDS)
			A	B	L	J	
ASTT-1030	1/2 - 13	3/4	2	2-1/2	5-1/4	1/2	1.00
ASTT-1039		1	2-1/8	2-3/4	5-1/2	1/2	1.20
ASTT-1830	3/4 - 16	3/4	2	2-1/2	5-1/4	1/2	1.20
ASTT-1839		1	2-1/8	2-3/4	5-1/2	1/2	1.40
ASTT-2730	1 - 14	3/4	2	2-1/2	5-1/8	1/2	1.50
ASTT-2739		1	2-1/4	3	9-1/2	1/2	3.34
ASTT-2749		1-1/4	2-1/4	3	9-3/4	1/2	3.35
ASTT-3330	1-1/8 - 12	3/4	2-1/4	4	11	1/2	3.50
ASTT-3339		1	2-1/8	3	9-1/2	1/2	6.10
ASTT-3349		1-1/4	2-1/8	3	9-13/16	1/2	6.10
ASTT-3630	1-1/4 - 12	3/4	2-1/4	4	12	1/2	4.96
ASTT-3639		1	2-1/4	3	9-5/8	1/2	4.04
ASTT-3649		1-1/4	2-1/4	3	10-9/16	1/2	4.50
ASTT-3653		1-1/2	2	2-3/4	5-1/2	1/2	3.10
ASTT-3658		2	2-1/4	3-1/2	11-1/4	1/2	5.54
ASTT-4430	1-1/2 - 12	3/4	2	2-1/2	5-1/4	1/2	1.80
ASTT-4439		1	2-7/8	4-1/4	7-7/8	1/2	3.48
ASTT-4449		1-1/4	2-1/8	3	9-3/4	1/2	7.20
ASTT-4453		1-1/2	2-1/8	3-1/8	9-3/4	1/2	7.70
ASTT-4458		2	2-1/8	3-5/8	10-3/8	1/2	8.45
ASTT-4460		2-1/2	2-1/8	3-1/2	10-1/4	1/2	8.85
ASTT-4462		3	2-1/4	4	6-7/8	1/2	6.38

ALUMINUM STUD CONNECTORS

TYPE ASTT Continued

CATALOG NUMBER	STUD DIA./THD.	PIPE SIZE (NPS)	DIMENSIONS - INCHES				WEIGHT (POUNDS)
			A	B	L	J	
ASTT-5039	1-3/4 - 12	1	2	2-3/4	5-1/2	1/2	2.00
ASTT-5049		1-1/4	2	3	5-3/4	1/2	2.70
ASTT-5053		1-1/2	2	3-1/4	6	1/2	3.00
ASTT-5058		2	2-3/8	3-1/2	10-1/2	1/2	10.20
ASTT-5062		3	2-1/4	4	7	1/2	6.40
ASTT-5449	2 - 12	1-1/4	2	3	6	1/2	2.70
ASTT-5453		1-1/2	2	3-1/4	6	1/2	3.40
ASTT-5458		2	2	3-1/2	6-3/8	1/2	4.80
ASTT-5460		2-1/2	2	3-3/4	6-5/8	1/2	6.00
ASTT-5462		3	2	4	7	1/2	6.30
ASTT-5749	2-1/4 - 12	1-1/4	2	3	5-3/4	1/2	2.80
ASTT-5753		1-1/2	2	3-1/4	6-1/4	1/2	3.60
ASTT-5758		2	2	3-1/2	6-1/4	1/2	4.70
ASTT-5760		2-1/2	2	3-3/4	6-1/2	1/2	5.60
ASTT-5953	2-1/2 - 12	1-1/2	2-1/2	3-1/4	6-5/8	1/2	4.50
ASTT-5958		2	2-3/8	3-1/2	6-3/4	1/2	5.40
ASTT-5960		2-1/2	2-3/8	3-3/4	7	1/2	6.20
ASTT-5962		3	2-3/8	4	7-1/4	1/2	7.00
ASTT-6158	3 - 12	2	3-1/2	3-1/2	12-3/8	1/2	12.0
ASTT-6160		2-1/2	2-7/8	3-3/4	7-5/8	1/2	6.80
ASTT-6162		3	2-7/8	4	7-7/8	5/8	7.70
ASTT-6163		3-1/2	2-3/8	4-1/4	7-1/2	5/8	8.50
ASTT-6164		4	3	4-1/2	8	5/8	8.20
ASTT-6167		5	2-7/8	5	8-7/8	5/8	10.80
ASTT-61560	3-1/4 - 12	2-1/2	2-3/8	3-3/4	7	5/8	7.20
ASTT-61562		3	2-3/8	4	7-1/4	5/8	8.50
ASTT-61563		3-1/2	2-3/8	4-1/4	7-1/2	5/8	9.00
ASTT-61564		4	2-7/8	4-1/4	8-1/4	5/8	9.90
ASTT-6260	3-1/2 - 12	2-1/2	2-3/8	3-3/4	7	5/8	7.70
ASTT-6262		3	3-1/8	4	8-1/8	5/8	8.50
ASTT-6263		3-1/2	2-3/8	4-1/4	7-1/2	5/8	9.60
ASTT-6264		4	2-3/8	4-1/4	7-1/2	5/8	10.20
ASTT-6360	4 - 12	2-1/2	2-3/8	3-3/4	7	5/8	8.70
ASTT-6362		3	2-3/8	4	7-1/4	5/8	9.80
ASTT-6363		3-1/2	2-3/8	4-1/4	7-1/2	5/8	10.60
ASTT-6364		4	3-3/4	4-1/4	9	5/8	12.00

ALUMINUM STUD CONNECTORS

TYPE ASTR

Angle Connector
Stud to Pipe

Pipe Clamp Alloy: 356-T6 aluminum
Stud Clamp Alloy: Electrical bronze
Pipe Hardware: Aluminum alloy
Stud Hardware: Silicon bronze
Pad Hardware: Stainless steel
Options: See Page 195

A variable-angle stud connector for copper stud to aluminum pipe. Allows 0° - 90° field adjustment for stud sizes 1-1/2" NPS and below, as indicated by Fig. 1 in the table below. Sizes above this level are factory-set, and take-off angle must be specified at time of order. Transition between copper and aluminum is made at the spade connection, which is tin plated and coated with contact sealant.

The ASTR is also available for aluminum stud to aluminum pipe. Add Suffix -AL to catalog.

Consult manufacturer for further details, unlisted and/or special applications. Metric options available for smooth and threaded stud connectors.

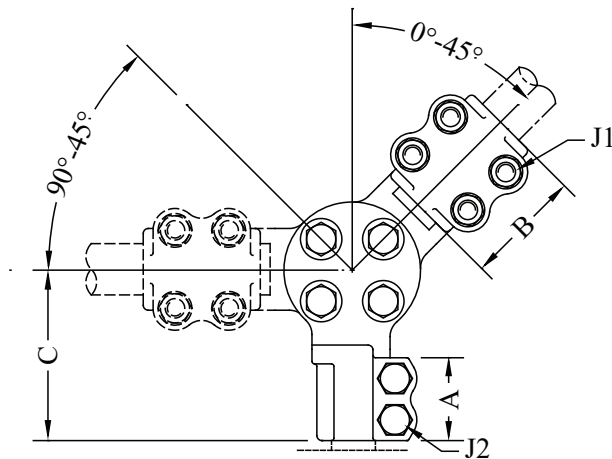

FIG. 1

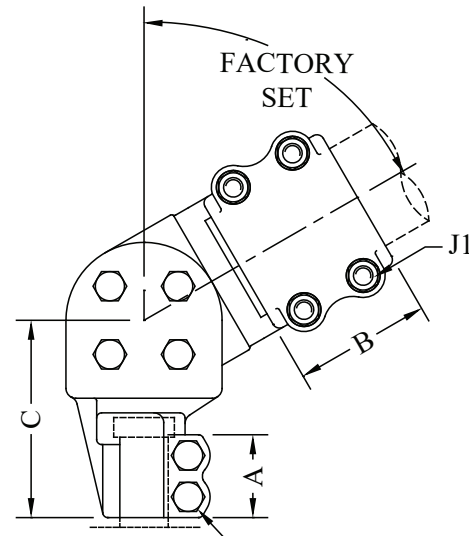

FIG. 2

CATALOG NUMBER	STUD DIA./THD.	FIG. NO.	PIPE SIZE (NPS)	DIMENSIONS - INCHES					WEIGHT (POUNDS)
				A	B	C	J1	J2	
ASTR-1830	3/4 - 16	1	3/4	1-13/16	2-3/8	4	1/2	1/2	4.00
ASTR-1839		1	1		3		1/2		4.00
ASTR-2730	1 - 14	1	3/4	2-1/8	2-3/8	4-1/4	1/2	1/2	4.50
ASTR-2739		1	1		3		1/2		4.50
ASTR-2749		1	1-1/4		3		1/2		5.00
ASTR-2753		1	1-1/2		3-1/8		1/2		5.50
ASTR-3330	1-1/8 - 12	1	3/4	2-1/8	2-3/8	4-3/8	1/2	1/2	5.00
ASTR-3339		1	1		3		1/2		5.00
ASTR-3349		1	1-1/4		3		1/2		5.50
ASTR-3353		1	1-1/2		3-1/8		1/2		6.00
ASTR-3358		2	2		3-1/2		1/2		6.50
ASTR-3639	1-1/4 - 12	1	1	2-1/8	3	4-1/2	1/2	1/2	5.25
ASTR-3649		1	1-1/4		3		1/2		5.50
ASTR-3653		1	1-1/2		3-1/8		1/2		6.00
ASTR-3658		2	2		3-1/2		1/2		6.50
ASTR-3660		2	2-1/2		3-1/2		1/2		7.00

ALUMINUM STUD CONNECTORS

TYPE ASTR Continued

CATALOG NUMBER	STUD DIA./THD.	FIG. NO.	PIPE SIZE (NPS)	DIMENSIONS - INCHES					WEIGHT (POUNDS)
				A	B	C	J1	J2	
ASTR-4449	1-1/2 - 12	1	1-1/4	2-1/8	3	4-5/8	1/2	1/2	6.25
ASTR-4453		1	1-1/2		3-1/8		1/2		6.75
ASTR-4458		2	2		3-1/2		1/2		7.25
ASTR-4460		2	2-1/2		3-1/2		1/2		7.75
ASTR-4462		2	3		4		5/8		10.00
ASTR-5053	1-3/4 - 12	2	1-1/2	2-3/8	3-1/8	5	1/2	1/2	8.50
ASTR-5058		2	2		3-1/2		1/2		9.00
ASTR-5060		2	2-1/2		3-1/2		1/2		9.50
ASTR-5062		2	3		4		5/8		10.75
ASTR-5453	2 - 12	2	1-1/2	2-3/8	3-1/8	5	1/2	1/2	10.00
ASTR-5458		2	2		3-1/2		1/2		10.50
ASTR-5460		2	2-1/2		3-1/2		1/2		11.00
ASTR-5462		2	3		4		5/8		13.25
ASTR-5758	2-1/4 - 12	2	2	2-5/8	3-1/2	5-1/4	1/2	1/2	11.50
ASTR-5760		2	2-1/2		3-1/2		1/2		12.00
ASTR-5762		2	3		3		5/8		14.25
ASTR-5958	2-1/2 - 12	2	2	2-5/8	3	5-1/4	1/2	1/2	13.75
ASTR-5960		2	2-1/2		3-1/2		1/2		14.25
ASTR-5962		2	3		4		5/8		16.50
ASTR-5963		2	3-1/2		4-3/8		5/8		17.50
ASTR-6160	3 - 12	2	2-1/2	3-1/8	3-1/2	6-1/8	1/2	5/8	17.25
ASTR-6162		2	3		4-3/8		5/8		19.50
ASTR-6163		2	3-1/2		4-3/8		5/8		20.50
ASTR-6164		2	4		4-1/2		5/8		22.00
ASTR-6262	3-1/2 - 12	2	3	3-1/8	4	6-1/4	5/8	5/8	21.50
ASTR-6263		2	3-1/2		4-3/8		5/8		22.50
ASTR-6264		2	4		4-1/2		5/8		24.00
ASTR-6362	4 - 12	2	3	3-1/4	4	6-3/8	5/8	5/8	25.00
ASTR-6363		2	3-1/2		4-3/8		5/8		26.00
ASTR-6364		2	4		4-1/2		5/8		27.50

TYPE WSTR

For welded connection to aluminum pipe instead of bolted, substitute the WSTR in the table above.

Metric options available for smooth and threaded stud connectors.

Consult manufacturer for further details, unlisted and/or special applications.

ALUMINUM STUD CONNECTORS

TYPE ASXTR

Bolted Expansion
Stud to Pipe

Pipe clamp: 356-T6 Aluminum
Stud clamp: Electric Bronze
Laminated straps: 1100-0 Aluminum
Pipe clamp hardware: Aluminum Alloy
Stud clamp hardware: Silicon Bronze
Pad Hardware: Stainless Steel
Options: See Page 195

A variable-angle expansion stud connector for copper stud to aluminum pipe. Type ASXTR is available with factory-set take-off angles of 0° - 90° to be specified at time of order. Laminated aluminum straps are welded to castings. When vertical flexing straps are required instead of the standard horizontal flexing straps, insert the suffix (-V) into the catalog number, Example: ASXTR-V-3658-A90. Weights are same as shown in table. Refer to factory for dimensions.

Transition between copper and aluminum is made at the spade connection, which is tin plated and coated with contact sealant.

Metric options available for smooth and threaded stud connectors.

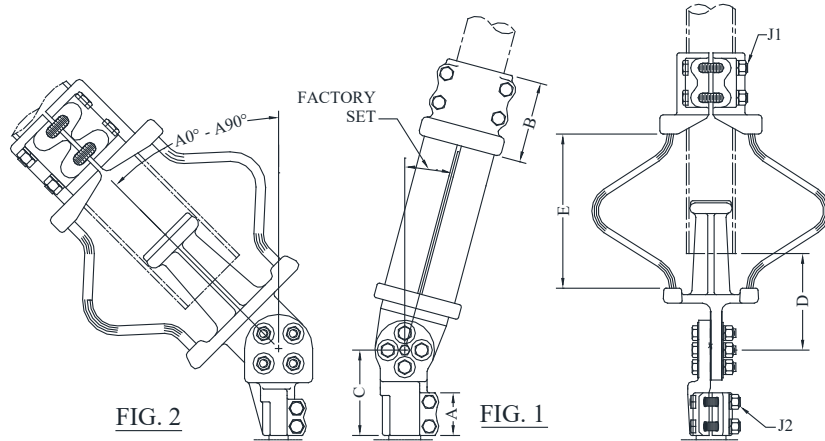

CATALOG NUMBER	STUD DIA./THD.	PIPE SIZE (NPS)	DIMENSIONS - INCHES							WEIGHT (POUNDS)
			A	B	C	D	E	J1	J2	
ASXTR-1030-A()	1/2 - 13	3/4	1-7/8	3-3/4	3-3/4	4	6	1/2	3/8	7.80
ASXTR-1039-A()		1	1-7/8	4	3-3/4	4-1/4	6	1/2	3/8	8.40
ASXTR-1430-A()	5/8 - 11	3/4	2	3-3/4	3-7/8	4	6	1/2	3/8	9.00
ASXTR-1439-A()		1	2	4	3-7/8	4-1/4	6	1/2	3/8	9.50
ASXTR-1839-A()	3/4 - 16	1	2-1/8	4	4	4-1/4	6	1/2	3/8	9.70
ASXTR-1849-A()		1-1/4	2-1/8	4-1/4	4	4-1/2	6-1/4	1/2	3/8	10.00
ASXTR-1853-A()		1-1/2	2-1/8	4-1/2	4	4-3/4	6-1/2	1/2	3/8	10.90
ASXTR-2739-A()	1 - 14	1	2	4	4-1/4	4-1/4	6	1/2	3/8	14.15
ASXTR-2749-A()		1-1/4	2	4-1/4	4-1/4	4-1/2	6-1/4	1/2	3/8	10.70
ASXTR-2753-A()		1-1/2	2	4-1/2	4-1/4	4-3/4	6-1/2	1/2	3/8	11.30
ASXTR-3339-A()	1-1/8 - 12	1	2-1/8	4	4-3/8	4-1/4	6	1/2	1/2	8.15
ASXTR-3349-A()		1-1/4	2-1/8	4-1/4	4-3/8	4-1/2	6-1/4	1/2	1/2	9.45
ASXTR-3353-A()		1-1/2	2-1/8	4-3/8	4-5/16	4-7/8	6-1/2	1/2	1/2	10.70
ASXTR-3358-A()		2	2-1/8	4-3/4	4-3/8	5-1/8	6-3/4	1/2	1/2	11.75
ASXTR-3649-A()	1-1/4 - 12	1-1/4	2-1/8	4-3/16	4-3/8	4-1/2	6-3/4	1/2	1/2	9.70
ASXTR-3653-A()		1-1/2	2-1/8	4-3/8	4-1/2	4-3/4	6-1/2	1/2	1/2	10.00
ASXTR-3658-A()		2	2-1/8	4-3/4	4-1/2	4-1/8	6-3/4	1/2	1/2	11.55
ASXTR-3660-A()		2-1/2	2-1/8	4-3/4	5	5-1/2	9	1/2	1/2	20.40
ASXTR-4449-A()	1-1/2 - 12	1-1/4	2-1/8	4-1/4	4-5/8	4-1/2	6	1/2	1/2	10.40
ASXTR-4453-A()		1-1/2	2-1/8	4-3/8	4-5/16	4-7/8	6-1/2	1/2	1/2	10.85
ASXTR-4458-A()		2	2-1/8	4-3/4	4-5/8	5-1/8	6-3/4	1/2	1/2	12.35
ASXTR-4460-A()		2-1/2	2-1/8	4-3/4	4-9/16	5-3/4	9	1/2	1/2	17.95

ALUMINUM STUD CONNECTORS

TYPE ASXTR Continued

CATALOG NUMBER	STUD DIA./THD.	PIPE SIZE (NPS)	DIMENSIONS - INCHES							WEIGHT (POUNDS)
			A	B	C	D	E	J1	J2	
ASXTR-5053-A ()	1-3/4 - 12	1-1/2	2-3/8	4-1/2	5	4-3/4	6-1/2	1/2	1/2	13.20
ASXTR-5058-A ()		2	2-3/8	4-3/4	5-5/16	3-1/2	6-3/4	1/2	1/2	15.90
ASXTR-5060-A ()		2-1/2	2-3/8	4-3/4	5-5/16	5-1/2	9	1/2	1/2	23.05
ASXTR-5458-A ()	2 - 12	2	2-3/8	4-3/4	5	5-1/8	6-3/4	1/2	1/2	14.00
ASXTR-5460-A ()		2-1/2	2-1/2	4-3/4	5	5-3/4	9	1/2	1/2	21.70
ASXTR-5462-A ()		3	2-3/8	5-3/8	5	5-1/2	9-1/2	5/8	1/2	22.70
ASXTR-5463-A ()		3-1/2	2-1/2	5-3/4	5	5-1/4	10	5/8	1/2	27.10
ASXTR-5958-A ()	2-1/2 - 12	2	2-5/8	4-3/4	5-1/4	5-1/8	6-3/4	1/2	1/2	25.20
ASXTR-5960-A ()		2-1/2	2-5/8	5-3/4	5-1/4	5-3/8	9	1/2	1/2	25.80
ASXTR-5962-A ()		3	2-5/8	5-3/8	5-1/4	5-1/2	9-1/2	5/8	1/2	26.40
ASXTR-5963-A ()		3-1/2	2-5/8	5-5/8	5-1/4	5-1/2	10	5/8	1/2	27.40
ASXTR-6160-A ()	3 - 12	2-1/2	3-1/8	4-3/4	6-1/8	5-3/8	9	1/2	5/8	22.25
ASXTR-6162-A ()		3	3-1/8	5-3/8	6-1/8	5-1/2	9-1/2	5/8	5/8	30.65
ASXTR-6163-A ()		3-1/2	3-1/8	5-3/4	6-1/8	5-1/2	10	5/8	5/8	35.00
ASXTR-6262-A ()	3-1/2 - 12	3	3-1/8	5-3/8	6-1/4	5-1/2	9-1/2	5/8	5/8	36.80
ASXTR-6263-A ()		3-1/2	3-1/8	5-5/8	6-1/4	5-1/2	10	5/8	5/8	38.80
ASXTR-6264-A ()		4	3-1/8	5-3/4	6-1/4	5-1/2	10	5/8	5/8	40.70
ASXTR-6362-A ()	4 - 12	3	3-1/4	5-3/8	6-3/8	5-1/2	9-1/2	5/8	5/8	38.90
ASXTR-6363-A ()		3-1/2	3-1/4	5-5/8	6-3/8	5-1/2	10	5/8	5/8	40.60
ASXTR-6364-A ()		4	3-1/4	5-3/4	6-3/8	5-1/2	10	5/8	5/8	42.50

TYPE WSXTR

For welded connection to aluminum pipe instead of bolted, substitute WSXTR in the table above. Consult manufacturer for further details, unlisted and/or special applications.

TYPE ASFFT

Expansion Semi-Flexible Stud to Pipe

Pipe Clamp: 356-T6 Aluminum
 Pipe Hardware: Aluminum Alloy
 Strap Hardware: Stainless Steel
 Strap: Copper
 Options: See Page 195

A semi-flexible stud connector for threaded copper stud to aluminum pipe. Laminated copper strap allows some angular misalignment between pipe and stud. Copper strap is soldered to form a solid tinned pad at each end.
 *Bronze contact nuts SHN are available individually or by adding -CCN to the catalog number.

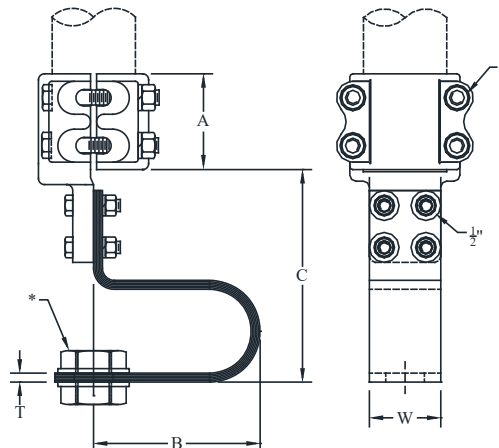

ALUMINUM STUD CONNECTORS

TYPE ASFFT Continued

CATALOG NUMBER	STUD DIA./THD.	PIPE SIZE (NPS)	DIMENSIONS - INCHES						WEIGHT (POUNDS)
			A	B	C	T	J	W	
ASFFT-1830	3/4 - 16	3/4	2-3/8	5-1/2	8	3/16	1/2	2	4.10
ASFFT-1839		1	3	5-1/2	8	1/4	1/2	2	4.30
ASFFT-1849		1-1/4	3	6	8	1/4	1/2	2	4.50
ASFFT-2730	1 - 14	3/4	2-3/8	5-1/2	8	3/16	1/2	2	4.40
ASFFT-2739		1	3	5-1/2	8	1/4	1/2	2	4.60
ASFFT-2749		1-1/4	3	6	8-1/4	3/8	1/2	2	4.80
ASFFT-2753		1-1/2	3-1/8	6-1/8	8-1/4	7/16	1/2	2	5.10
ASFFT-3330	1-1/8 - 12	3/4	4	6-11/16	8-5/16	3/16	1/2	3	5.85
ASFFT-3339		1	3	6-1/2	8	3/16	1/2	3	5.55
ASFFT-3349		1-1/4	3	4-7/8	8-3/4	1/4	1/2	3	6.55
ASFFT-3353		1-1/2	3-1/8	6-3/8	8-3/4	9/32	1/2	3	7.45
ASFFT-3358		2	3-1/2	6-13/16	8-7/8	5/16	1/2	3	10.20
ASFFT-3639	1-1/4 - 12	1	3	5-3/4	8	3/16	1/2	3	6.30
ASFFT-3649		1-1/4	3	4-7/8	8-3/4	1/4	1/2	3	6.60
ASFFT-3653		1-1/2	3-1/8	4-7/8	8-3/8	1/4	1/2	3	7.10
ASFFT-3658		2	3-1/2	6-3/8	8-3/4	3/8	1/2	3	11.15
ASFFT-3660		2-1/2	3-1/2	7	8-3/4	3/8	1/2	3	11.85
ASFFT-4449	1-1/2 - 12	1-1/4	3	4-7/8	8-3/4	1/4	1/2	3	9.65
ASFFT-4453		1-1/2	3	6-3/8	8-3/4	9/32	1/2	3	7.10
ASFFT-4458		2	3-1/2	7	8-7/8	3/8	1/2	3	11.70
ASFFT-4460		2-1/2	3-1/2	7	8-3/4	3/8	1/2	3	11.80
ASFFT-5453	2 - 12	1-1/2	3-1/8	7	9-7/8	3/8	1/2	4	15.00
ASFFT-5458		2	3-1/2	6-7/8	9-1/2	3/8	1/2	4	14.70
ASFFT-5460		2-1/2	3-1/2	7-3/8	9-1/2	1/2	1/2	4	18.20
ASFFT-5462		3	4	7-7/16	10-3/4	5/8	5/8	4	24.20

TYPE ASFFT90 - A 90° semi-flexible stud connector for threaded copper stud to aluminum pipe. This connector is the same as type ASFFT above except for 90° take-off. To specify, substitute ASFFT90 in the table above. *Bronze contact nuts SHN are available individually or by adding -CCN to the catalog number.

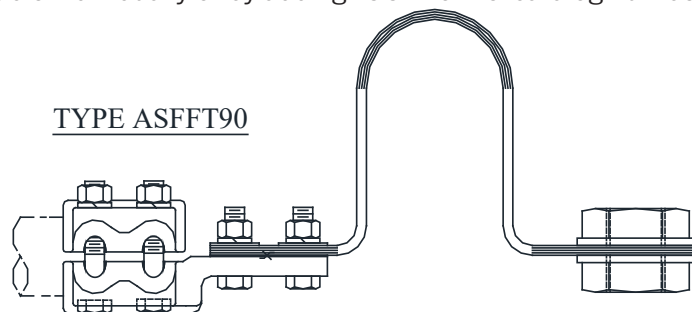

TYPE WSFFT - For welded connection to aluminum pipe instead of bolted, substitute the WSFFT or WSFFT90 in the table above. Consult manufacturer for further details, unlisted and/or special applications.

BRONZE STUD CONNECTORS



SNFT



SNFT90



SNFV



SCC



SCC2



SAX

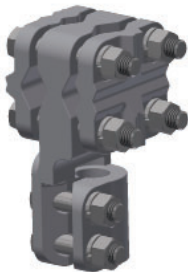

SAX2



SXR/SXR2



STT



SATA



SXT



SFFT

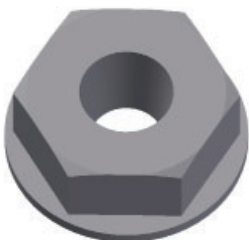

SHN



SFFT90



SNX

BRONZE STUD CONNECTORS

SEFCOR bronze stud connectors are cast from certified ingot. Only high quality electrical bronze per ASTM-B145 is utilized to insure the current-carrying capability as well as mechanical strength.

Metric options are available for smooth and threaded stud connectors. Contact factory for details.

This section is arranged in the following sequence for the convenience of the user:

Stud to Flat Pad
Stud to Cable
Stud to Pipe

OPTIONS

A suffix added to a catalog number denotes a variation or option made to the standard cataloged item. The suffixes listed below display the various options available with SEFCOR bronze stud connectors. For those part numbers not listed or for special applications, please refer to factory.

A ()	Factory-set angle, (i.e.; A45, provides for a 45° angle)
B	Flexible-braid elements instead of laminations
CCN	Supplied with contact nuts
CNS	Supplied with cap nuts
FF	Finish both sides of contact pad when not customary to do so
GS	Galvanized steel hardware in lieu of standard hardware
H	Heavy (extra-thickness contact pad)
SND	Tin plate entire assembly
SP	Special requirement, refer to factory
SS	Stainless steel hardware instead of standard hardware
TØ	Smooth stud bore - no threads
T ()	Special stud threads, (i.e.; T14, provides 14 threads per inch)
TP	Tin-plated contact pad
AG	Silver-Plate entire assembly

NOTES:

1. Actual dimensions (other than those established by NEMA) of connectors shown may vary slightly.
If exact dimensions are required, refer to factory or see assembly drawing.
2. Consult manufacturer for further details, unlisted and/or special applications.

BRONZE STUD CONNECTORS

TYPE SATA

Variable Angle
Stud to Pipe

Pipe clamp: Electrical Bronze
Stud Clamp: Electrical Bronze
Clamping Hardware: Silicon Bronze
Options: See Page 207

A Variable-angle stud connector for copper stud to copper pipe, allows 0° - 90° field adjustment for stud sizes 1-1/2" and below and pipe sizes 1-1/2" NPS, and below, as indicated by Fig. 1 in the table below.

Sizes above this level are factory-set, and take-off angle must be specified at time of order.

Metric options available for smooth and threaded stud connectors.

Contact factory for details.

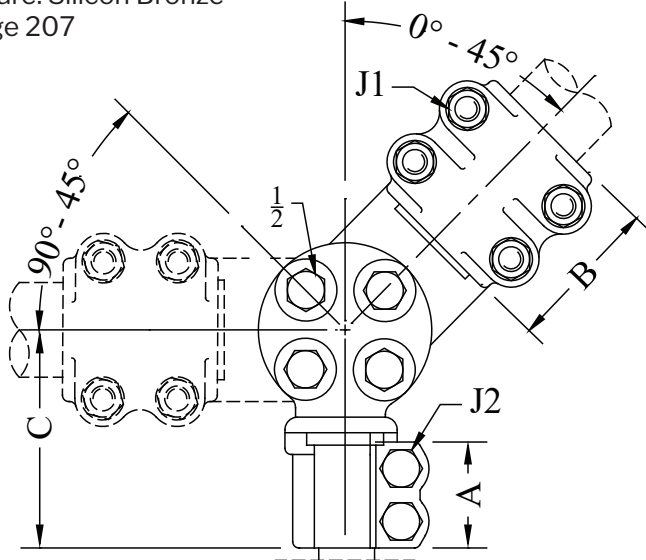

FIG. 1

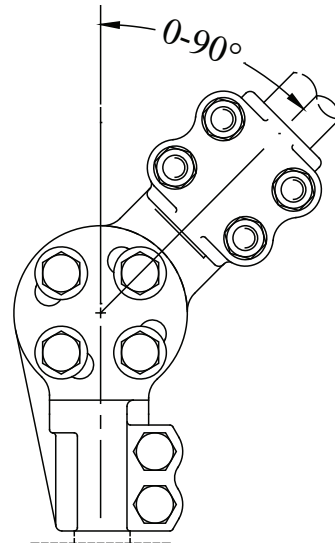

FIG. 2

CATALOG NUMBER	STUD DIA./THD.	FIG. NO.	PIPE SIZE (NPS)	DIMENSIONS - INCHES					WEIGHT (POUNDS)
				A	B	C	J1	J2	
SATA-1830	3/4 - 16	1	3/4	1-3/4	2-3/8	4	1/2	3/8	5.00
SATA-1839		1	1		3		1/2		
SATA-2730	1 - 14	1	3/4	2	2-3/8	4-1/4	1/2	3/8	5.50
SATA-2739		1	1		3		5.50		
SATA-2749		1	1-1/4		3		6.00		
SATA-2753		1	1-1/2		3-1/8		1/2		6.50
SATA-3330	1-1/8 - 12	1	3/4	2-1/8	2-3/8	4-3/8	1/2	1/2	7.00
SATA-3339		1	1		3		1/2		10.30
SATA-3349		1	1-1/4		3		1/2		8.80
SATA-3353		1	1-1/2		3-1/8		1/2		7.00
SATA-3358		2	2		3-1/2		1/2		7.50
SATA-3639	1-1/4 - 12	1	1	2-1/8	3	4-1/2	1/2	1/2	6.25
SATA-3649		1	1-1/4		3		1/2		6.50
SATA-3653		1	1-1/2		3-1/8		1/2		11.60
SATA-3658		2	2		3-1/2		1/2		7.50
SATA-3660		2	2-1/2		3-1/2		1/2		8.00

Continued on next page

SEFCOR

BRONZE STUD CONNECTORS

TYPE SATA Continued

CATALOG NUMBER	STUD DIA./THD.	FIG. NO.	PIPE SIZE (NPS)	DIMENSIONS - INCHES					WEIGHT (POUNDS)
				A	B	C	J1	J2	
SATA-4449	1-1/2 - 12	1	1-1/4	2-1/8	3	4-5/8	1/2	1/2	14.20
SATA-4453		1	1-1/2		3-1/8		1/2		7.80
SATA-4458		2	2		3-1/2		1/2		13.10
SATA-4460		2	2-1/2		3-1/2		1/2		15.90
SATA-4462		2	3		4		5/8		20.80
SATA-5053	1-3/4 - 12	2	1-1/2	2-3/8	3-1/8	5	1/2	1/2	14.00
SATA-5058		2	2		3-1/2		1/2		17.70
SATA-5060		2	2-1/2		3-1/2		1/2		18.05
SATA-5062		2	3		4		5/8		11.75
SATA-5453	2 - 12	2	1-1/2	2-3/8	3-1/8	5	1/2	1/2	14.05
SATA-5458		2	2		3-1/2		1/2		17.75
SATA-5460		2	2-1/2		3-1/2		1/2		12.00
SATA-5462		2	3		4		5/8		14.25
SATA-5758	2-1/4 - 12	2	2	2-5/8	3-1/2	5-1/4	1/2	1/2	20.40
SATA-5760		2	2-1/2		3-1/2		1/2		13.00
SATA-5762		2	3		4		5/8		15.25
SATA-5958	2-1/2 - 12	2	2	2-5/8	3-1/2	5-1/4	1/2	1/2	14.75
SATA-5960		2	2-1/2		3-1/2		1/2		21.20
SATA-5962		2	3		4		5/8		17.50
SATA-5963		2	3-1/2		4-3/8		5/8		27.30
SATA-6160	3 - 12	2	2-1/2	3-1/8	3-1/2	6-1/8	1/2	5/8	18.25
SATA-6162		2	3		4		5/8		20.50
SATA-6163		2	3-1/2		4-3/8		5/8		31.55
SATA-6164		2	4		4-1/2		5/8		23.00
SATA-6262	3-1/2 - 12	2	3	3-1/8	4	6-1/4	5/8	5/8	22.50
SATA-6263		2	3-1/2		4-3/8		5/8		23.50
SATA-6264		2	4		4-1/2		5/8		25.00
SATA-6362	4 - 12	2	3	3-1/4	4	6-3/8	5/8	5/8	26.00
SATA-6363		2	3-1/2		4-3/8		5/8		27.00
SATA-6364		2	4		4-1/2		5/8		28.50

BRONZE STUD CONNECTORS

TYPE SAX

Bolted Two Way
Stud to Cable

All-bronze stud connector for copper stud to cable, end-on or 90°. On Sizes marked (*), cap is four-way reversible design. On other sizes, full conductor range is accommodated by rotating cap 90°. Metric options available for smooth and threaded stud connectors. Contact factory for details.

Casting Alloy: Electrical Bronze
Clamping Hardware: Silicon Bronze
Options: See Page 207

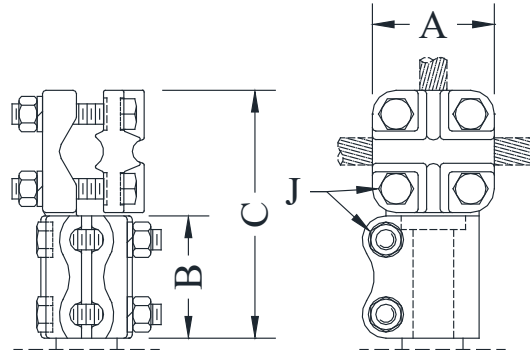

CATALOG NUMBER	STUD DIA./THD.	CONDUCTOR RANGE	DIMENSIONS - INCHES				WEIGHT (POUNDS)
			A	B	C	J	
SAX-8250	3/4 - 16	#8 SOL - 4/0 STR	1-7/8	2	4	3/8	2.45
*SAX-8256		#6 SOL - 500 MCM	2-1/4	2	4-3/8	3/8	3.20
SAX-8450	1 - 14	#8 SOL - 4/0 STR	1-7/8	2	4	3/8	2.50
*SAX-8456		#6 SOL - 500 MCM	2-1/4	2	4-5/16	3/8	3.20
SAX-8462		4/0 STR - 800 MCM	3	2-1/4	5-3/8	1/2	4.00
*SAX-8466		#2 STR - 1000 MCM	3	2-1/8	5-3/8	1/2	5.30
SAX-8550	1-1/8 - 12	#8 SOL - 4/0 STR	1-7/8	2	4	3/8	2.70
*SAX-8556		#6 SOL - 500 MCM	2-1/4	2-1/4	4-9/16	3/8	3.45
SAX-8562		4/0 STR - 800 MCM	3	2-1/4	5-1/2	1/2	5.25
*SAX-8566		#2 STR - 1000 MCM	3	2-1/2	5-5/8	1/2	4.80
SAX-8650	1-1/4 - 12	#8 SOL - 4/0 STR	1-7/8	2	4-1/2	3/8	2.50
*SAX-8656		#6 SOL - 500 MCM	2-1/4	2-1/4	5-1/16	3/8	4.20
SAX-8662		4/0 STR - 800 MCM	3	2-3/4	5-7/8	1/2	7.00
*SAX-8666		#2 STR - 1000 MCM	3	2-1/2	5-5/8	1/2	4.85
SAX-8750	1-1/2 - 12	#8 SOL - 4/0 STR	1-7/8	2-1/2	4-1/2	3/8	3.55
*SAX-8756		#6 SOL - 500 MCM	2-1/4	2-1/8	4-7/8	3/8	4.35
SAX-8762		4/0 STR - 800 MCM	3	2-1/4	5-5/8	1/2	5.30
*SAX-8766		#2 STR - 1000 MCM	3	2-1/4	5-5/8	1/2	5.20
*SAX-8778		#2 SOL - 2000 MCM	3-3/8	2-1/4	6-1/8	1/2	7.95
*SAX-8856	1-3/4 - 12	#6 SOL - 500 MCM	2-1/4	2-1/2	5-3/16	3/8	4.75
SAX-8862		4/0 STR - 800 MCM	3	2-3/4	5-7/8	1/2	6.00
SAX-8950	2 - 12	#8 SOL - 4/0 STR	1-7/8	2-1/2	4-1/2	3/8	5.50
*SAX-8956		#6 SOL - 500 MCM	2-1/4	2-1/4	5-3/16	3/8	4.75
SAX-8962		4/0 STR - 800 MCM	3	2-3/4	6-1/8	1/2	9.20
*SAX-8966		#2 STR - 1000 MCM	3	2-3/4	6-3/16	1/2	5.85
*SAX-9156	2-1/2 - 12	#6 SOL - 500 MCM	2-1/4	2-1/2	5-1/8	3/8	8.00
SAX-9162		4/0 STR - 800 MCM	3	2-3/4	6	1/2	9.00
*SAX-9166		#2 STR - 1000 MCM	3	3-1/8	7-1/2	1/2	16.75

BRONZE STUD CONNECTORS

TYPE SAX2

Bolted Two Way
Stud to Two Cables

All-bronze stud connector for copper stud to two cable, end-on or 90°. On sizes marked (*), cap is four-way reversible design. On other sizes, full conductor range is accommodated by rotating cap 90°. Metric options available for smooth and threaded stud connectors. Contact factory for details.

Casting Alloy: Electrical Bronze
Clamping Hardware: Silicon Bronze
Options: See Page 207

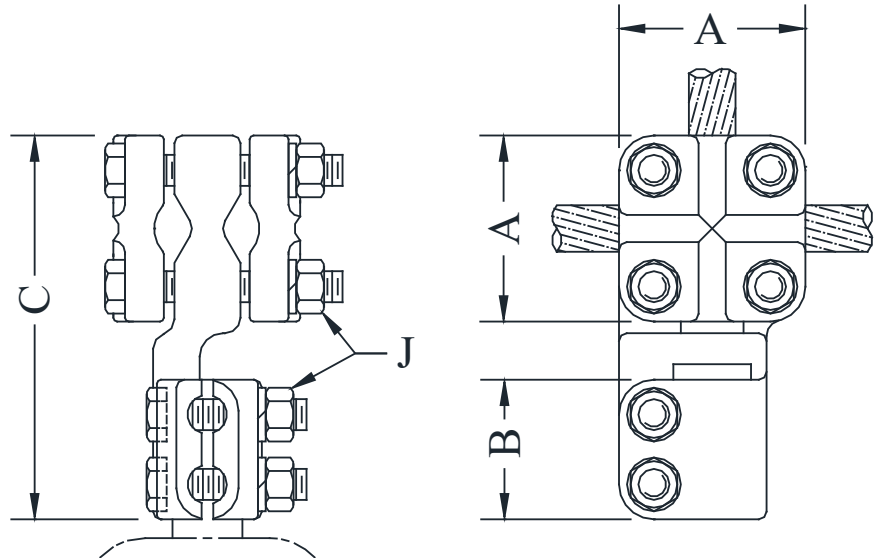

CATALOG NUMBER	STUD DIA./THD.	CONDUCTOR RANGE	DIMENSIONS - INCHES				WEIGHT (POUNDS)
			A	B	C	J	
SAX2-8250	3/4 - 16	#8 SOL - 4/0 STR	1-7/8	2	4-1/8	3/8	2.75
SAX2-8450	1 - 14	#8 SOL - 4/0 STR	1-7/8	2	4-1/8	3/8	3.25
* SAX2-8456		#6 SOL - 500 MCM	3	2-1/4	6-1/4	1/2	8.00
SAX2-8550	1-1/8 - 12	#8 SOL - 4/0 STR	1-7/8	2-1/4	4-3/8	3/8	3.25
* SAX2-8556		#6 SOL - 500 MCM	3	2-1/4	6-1/4	1/2	8.00
SAX2-8562		4/0 STR - 800 MCM	3	2-1/4	5-5/8	1/2	6.50
SAX2-8650	1-1/4 - 12	#8 SOL - 4/0 STR	1-7/8	2-1/4	4-3/8	3/8	3.50
* SAX2-8656		#6 SOL - 500 MCM	3	2-1/4	6-1/4	1/2	7.00
SAX2-8662		4/0 STR - 800 MCM	3	2-1/4	5-7/8	1/2	7.00
* SAX2-8756	1-1/2 - 12	#6 SOL - 500 MCM	3	2-1/2	6-1/2	1/2	9.00
SAX2-8762		4/0 STR - 800 MCM	3	2-1/4	5-5/8	1/2	7.00
* SAX2-8766		#2 STR - 1000 MCM	2-7/8	2-1/4	5-7/8	1/2	8.90
* SAX2-8956	2 - 12	#6 SOL - 500 MCM	3	2-1/2	6-9/16	1/2	11.05
SAX2-8962		4/0 STR - 800 MCM	3	2-3/4	6-1/8	1/2	8.70
* SAX2-8966		#2 STR - 1000 MCM	3	2-1/2	6-1/8	1/2	11.05
SAX2-9162	2-1/2 - 12	4/0 STR - 800 MCM	3	2-3/4	6-1/8	1/2	9.00
* SAX2-9166		#2 STR - 1000 MCM	3	2-3/4	6-1/8	1/2	9.00
* SAX2-9266	3 - 12	#2 STR - 1000 MCM	3	3-1/8	6-13/16	1/2	12.50

BRONZE STUD CONNECTORS

TYPE SCC

Bolted
Stud to Cable

All-bronze stud connector for copper stud to range of copper cable.
Reversible cap assures effective clamping on a full range of conductor sizes.
For 90° take-off, insert SCC90 in place of SCC in the table below.
Metric options available for smooth and threaded stud connectors.
Contact factory for details.

Casting Alloy: Electrical Bronze
Clamping Hardware: Silicon Bronze
Options: See Page 207

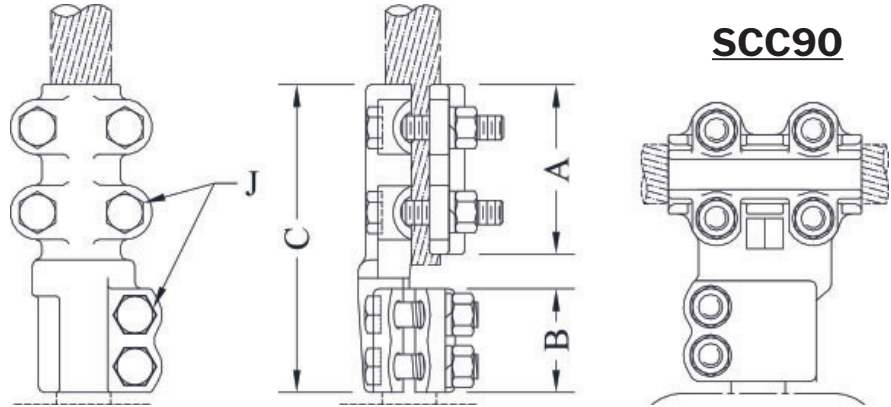

CATALOG NUMBER	STUD DIA./THD.	CONDUCTOR RANGE	DIMENSIONS - INCHES				WEIGHT (POUNDS)
			A	B	C	J	
SCC-1811	3/4 - 16	#6 SOL - 4/0 STR	3-1/4	2	5-3/8	3/8	2.55
SCC-1814		#4W - 300 MCM	3-1/4	1-3/4	5-1/2	3/8	2.80
SCC-2714	1 - 14	#4W - 300 MCM	3-1/4	2	5-7/8	3/8	3.80
SCC-2720		1/0 SOL - 500 MCM	3-9/16	2	6-1/16	3/8	3.30
SCC-3311	1-1/8 - 12	#6 SOL - 4/0 STR	3-1/8	2-1/8	5-7/8	3/8	3.05
SCC-3314		#4W - 300 MCM	3-1/4	2-1/8	6	3/8	3.10
SCC-3320		1/0 SOL - 500 MCM	3-7/16	2-1/8	6-3/8	3/8	3.50
SCC-3334		4/0 SOL - 1000 MCM	3-1/2	2-1/8	6-3/8	1/2	5.75
SCC-3614	1-1/4 - 12	#4W - 300 MCM	3-3/8	2-1/4	5-3/4	3/8	3.25
SCC-3620		1/0 SOL - 500 MCM	3-7/16	2-1/8	6-5/16	3/8	3.75
SCC-3634		4/0 SOL - 1000 MCM	4-1/4	2-1/4	7-1/16	1/2	4.85
SCC-4414	1-1/2 - 12	#4W - 300 MCM	3-1/4	2-1/8	6	3/8	4.10
SCC-4420		1/0 SOL - 500 MCM	3-7/16	2-1/8	6-3/16	3/8	4.10
SCC-4434		4/0 SOL - 1000 MCM	4	2-1/8	7	1/2	6.55
SCC-5014	1-3/4 - 12	#4W - 300 MCM	3-1/2	2-3/8	7-1/4	1/2	5.10
SCC-5020		1/0 SOL - 500 MCM	3-3/4	2-3/8	7-1/2	1/2	6.35
SCC-5034		4/0 SOL - 1000 MCM	4-1/4	2-3/8	7-5/8	1/2	7.25
SCC-5048R		4/0 SOL - 2000 MCM	4	2-1/4	6-7/8	1/2	8.50
SCC-5414	2 - 12	#4 SOL - 300 MCM	3-3/4	2-1/2	7-3/4	1/2	5.75
SCC-5420		1/0 SOL - 500 MCM	2-3/4	2-7/16	10-1/16	1/2	11.20
SCC-5434		4/0 SOL - 1000 MCM	4	2-1/2	7-1/2	1/2	8.60
SCC-5914	2-1/2 - 12	#4W - 300 MCM	4-1/4	2-3/4	7-1/2	1/2	7.25
SCC-5920		1/0 SOL - 500 MCM	4-1/2	2-3/4	7-5/8	1/2	8.70
SCC-5934		4/0 SOL - 1000 MCM	4-1/4	2-3/4	7-1/4	1/2	10.00
SCC-6134	3 - 12	#4 STR - 1000 MCM	3-1/2	3-1/8	12-7/16	1/2	21.80
SCC-6148		1500 MCM - 2000 MCM	5	3-1/8	13-7/8	1/2	23.25

BRONZE STUD CONNECTORS

TYPE SCC2

Bolted

Stud to Two Cables

All-Bronze stud connector for copper stud to two cables and-on.

Stud clamp is two-piece design.

Reversible caps assure effective clamping over the full range of conductor sizes.

Metric options available for smooth and threaded stud connectors.

Contact factory for details.

Casting Alloy: Electrical Bronze

Clamping Hardware: Silicon Bronze

Options: See Page 207

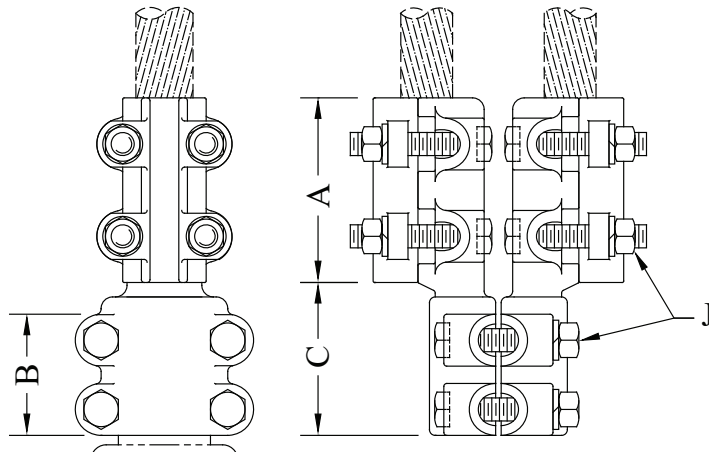

CATALOG NUMBER	STUD DIA. / THD.	CONDUCTOR RANGE	DIMENSIONS - INCHES				WEIGHT (POUNDS)
			A	B	C	J	
SCC2-2714	1 - 14	#4 SOL - 300 MCM	CONTACT FACTORY FOR DETAILS				
SCC2-2720		1/0 SOL - 500 MCM					
SCC2-3314	1-1/8 - 12	#4 SOL - 300 MCM	CONTACT FACTORY FOR DETAILS				
SCC2-3320		1/0 SOL - 500 MCM					
SCC2-3328		4/0 SOL - 800 MCM	3-1/2	2-1/8	2-3/4	1/2	8.90
SCC2-3334		4/0 SOL - 1000 MCM	CONTACT FACTORY FOR DETAILS				
SCC2-3614	1-1/4 - 12	#4 SOL - 300 MCM	CONTACT FACTORY FOR DETAILS				
SCC2-3620		1/0 SOL - 500 MCM					
SCC2-3634		4/0 SOL - 1000 MCM					
SCC2-4414	1-1/2 - 12	#4 SOL - 300 MCM	CONTACT FACTORY FOR DETAILS				
SCC2-4420		1/0 SOL - 500 MCM					
SCC2-4434		4/0 SOL - 1000 MCM	4	2-1/8	3-1/16	1/2	12.15
SCC2-5014	1-3/4 - 12	#4 SOL - 300 MCM	CONTACT FACTORY FOR DETAILS				
SCC2-5020		1/0 SOL - 500 MCM					
SCC2-5034		4/0 SOL - 1000 MCM	3-1/2	2-1/8	2-7/8	1/2	10.05
SCC2-5414	2 - 12	#4 SOL - 300 MCM	CONTACT FACTORY FOR DETAILS				
SCC2-5420		1/0 SOL - 500 MCM					
SCC2-5434		4/0 SOL - 1000 MCM	4	2-5/8	3-3/8	1/2	13.65
SCC2-5720	2-1/4 - 12	1/0 SOL - 500 MCM	CONTACT FACTORY FOR DETAILS				
SCC2-5734		4/0 SOL - 1000 MCM					
SCC2-5920	2-1/2 - 12	1/0 SOL - 500 MCM	CONTACT FACTORY FOR DETAILS				
SCC2-5934		4/0 SOL - 1000 MCM					
SCC2-6134	3 - 12	#4 STR - 1000 MCM	CONTACT FACTORY FOR DETAILS				

BRONZE STUD CONNECTORS

TYPE SFFT

Bolted Expansion - Semi-Flex
Stud to Pipe

Casting Alloy: Electric Bronze
Clamping Hardware: Silicon Bronze
Options: See Page 207

All-bronze semi-flexible stud connector for threaded stud to standard pipe. Laminated copper strap allows some angular misalignment between pipe and stud. Not recommended as a supporting member.

Laminated strap is soldered to form a solid tinned pad at each end.

*Bronze contact nuts SHN are available individually or by adding -CCN to the catalog number.

Metric options available for smooth and threaded stud connectors.

Contact factory for details.

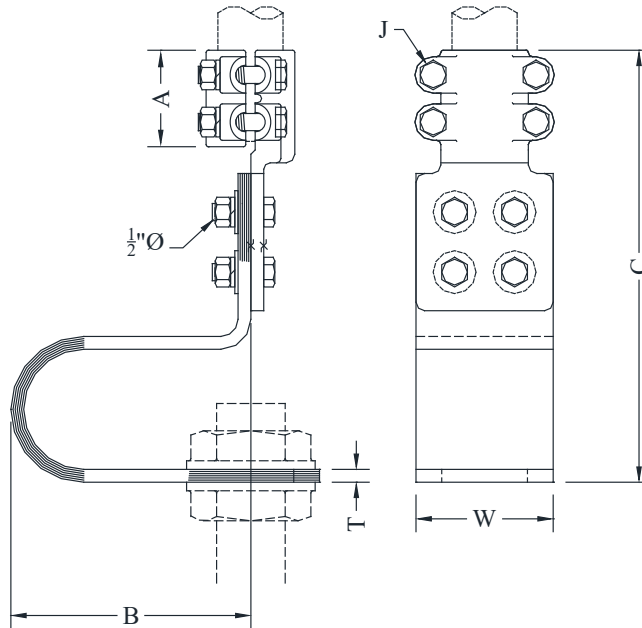

CATALOG NUMBER	STUD DIA./THD.	PIPE SIZE (NPS)	DIMENSIONS - INCHES						WEIGHT (POUNDS)
			A	B	C	J	T	W	
SFFT-2730	1-14	3/4	2-3/8	6-1/2	10-9/16	3/8	3/16	3	9.45
SFFT-2739		1	2-1/2	6-1/2	10-5/8	3/8	3/16	3	9.45
SFFT-2749		1-1/4	2-3/4	6-1/2	10-11/16	1/2	3/16	3	9.45
SFFT-2753		1-1/2	2-13/16	6-7/16	11	1/2	3/16	3	9.45
SFFT-3330	1-1/8 - 12	3/4	2-7/16	6-13/16	10-15/16	3/8	5/16	3	9.70
SFFT-3339		1	2	5-3/4	9-3/4	3/8	3/16	3	10.05
SFFT-3349		1-1/4	2-3/4	6-1/4	10-3/4	1/2	1/4	3	9.35
SFFT-3353		1-1/2	2-3/4	7	11-3/4	1/2	1/4	3	14.75
SFFT-3630	1-1/4 - 12	3/4	2	6-1/4	10-9/16	3/8	3/16	3	6.67
SFFT-3639		1	2-1/2	6-1/4	9-3/4	3/8	3/16	3	7.00
SFFT-3649		1-1/4	3	4-7/8	11-1/2	1/2	9/32	3	10.65
SFFT-3653		1-1/2	2-3/4	7	10-7/8	1/2	3/8	3	13.15
SFFT-3658		2	3	7	12	1/2	1/2	3	15.00

BRONZE STUD CONNECTORS

TYPE SFFT Continued

CATALOG NUMBER	STUD DIA./THD.	PIPE SIZE (NPS)	DIMENSIONS - INCHES						WEIGHT (POUNDS)
			A	B	C	J	T	W	
SFFT-4430	1-1/2 - 12	3/4	2	6	9-3/4	3/8	1/8	3	5.65
SFFT-4439		1	2	5-1/8	10	3/8	3/16	3	7.45
SFFT-4449		1-1/4	2-3/4	6-1/2	10-3/4	1/2	1/4	3	9.50
SFFT-4453		1-1/2	2-3/4	7	11	1/2	3/8	3	13.55
SFFT-4458		2	3-1/2	7	12-1/2	1/2	1/2	3	17.45
SFFT-4460		2-1/2	3-1/2	7-1/8	12-3/8	1/2	1/2	3	18.25
SFFT-4462		3	4	7-1/4	13-7/8	5/8	1/2	4	31.10
SFFT-5449	2 - 12	1-1/4	3	7	12-7/16	1/2	3/8	4	16.00
SFFT-5453		1-1/2	2-13/16	7	12-5/8	1/2	3/8	4	17.80
SFFT-5458		2	3-1/2	7-7/16	13-5/16	1/2	13/32	4	19.70
SFFT-5460		2-1/2	3-1/2	7	13	1/2	3/8	4	29.70
SFFT-5462		3	4	6-3/4	14-1/4	5/8	5/8	4	40.75

TYPE SHN

Contact Nut for Threaded Stud

Electrical bronze contact nut used in pairs for connecting types SFFT, SFFT90, ASFFT, and ASFFT90 to threaded copper stud. For stud threads other than listed, change last two digits of catalog number to number of threads required.

Casting Alloy: Electric Bronze

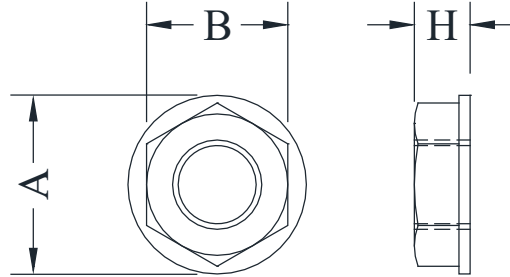

CATALOG NUMBER	STUD DIA./THD.	DIMENSIONS - INCHES			WEIGHT (POUNDS)
		A	B	H	
SHN-14-18	5/8 - 18	1-1/2	1-1/4	5/16	0.25
SHN-18-16	3/4 - 16	2	1-5/8	3/4	0.50
SHN-21-14	7/8 - 14	2	1-3/4	1/2	0.40
SHN-27-14	1 - 14	2	1-5/8	3/4	0.50
SHN-33-12	1-1/8 - 12	2-1/4	1-13/16	13/16	0.50
SHN-36-12	1-1/4 - 12	2-1/2	2	7/8	0.75
SHN-44-12	1-1/2 - 12	3	2-3/8	15/16	1.35
SHN-50-12	1-3/4 - 12	3-1/4	2-5/8	1	2.00
SHN-54-12	2 - 12	3-3/4	3-1/8	1-1/8	2.50
SHN-57-12	2-1/4 - 12	4	3-3/8	1-1/8	2.75
SHN-59-12	2-1/2 - 12	4-1/4	3-5/8	1-1/8	3.00
SHN-61-12	3 - 12	4-1/2	4	1-1/8	3.50

SEFCOR

BRONZE STUD CONNECTORS

TYPE SFFT90

90° Expansion - Semi-Flex
Stud to Pipe

Casting Alloy: Electrical Bronze
Clamping Hardware: Silicon Bronze
Options: See Page 207

All-bronze semi-flexible stud connector for threaded stud to standard copper pipe at 90°.

Laminated copper strap allows some vertical angular misalignment.
Not recommended as a full supporting member.

Laminated strap is soldered to form a solid, tinned pad at each end.

Metric options available for smooth and threaded stud connectors.

Contact factory for details.

*Bronze contact nuts SHN are available individually or by adding -CCN to the catalog number.

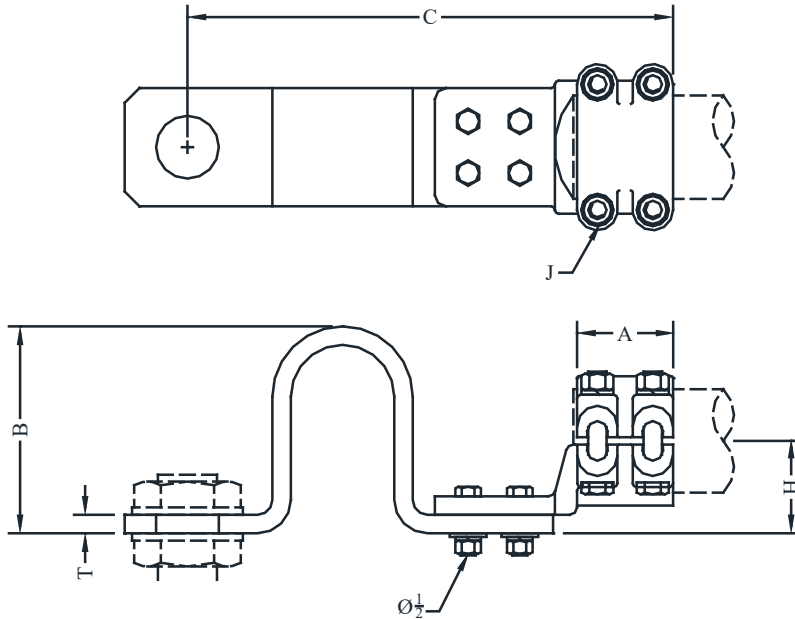

CATALOG NUMBER	STUD DIA./THD.	PIPE SIZE (NPS)	DIMENSIONS - INCHES					WEIGHT (POUNDS)
			A	B	C	T	H	
SFFT90-1830	3/4 - 16	3/4	2-1/2	5	12-1/8	3/16	1-1/4	4.70
SFFT90-1839		1	2-1/2	6-1/2	12-3/4	7/32	1-1/4	5.15
SFFT90-1849		1-1/4	2-1/2	7	13-5/16	3/8	1-1/4	5.65
SFFT90-2730	1 - 14	3/4	2-1/2	5	12-1/8	3/16	1-1/4	5.05
SFFT90-2739		1	2-1/2	6-1/2	12-3/4	7/32	1-1/4	5.75
SFFT90-2749		1-1/4	2-1/2	7	12-3/4	1/4	1-1/4	6.25
SFFT90-2753		1-1/2	2-1/2	7	13-5/16	3/8	1-1/4	6.95
SFFT90-3330	1-1/8 - 12	3/4	2-1/2	5	12-1/2	3/16	1-1/4	6.70
SFFT90-3339		1	2-1/2	6-1/2	12-3/4	7/32	1-1/2	8.65
SFFT90-3349		1-1/4	2-3/4	7	13-5/16	3/8	0	13.70
SFFT90-3353		1-1/2	2-3/4	7	13-7/8	1/2	0	12.25

BRONZE STUD CONNECTORS

TYPE SFFT90 Continued

CATALOG NUMBER	STUD DIA./THD.	PIPE SIZE (NPS)	DIMENSIONS - INCHES					WEIGHT (POUNDS)
			A	B	C	T	H	
SFFT90-3630	1-1/4 - 12	3/4	2	5	12-9/16	3/16	1-1/16	10.50
SFFT90-3639		1	2-3/4	6	12-3/4	7/32	0	11.35
SFFT90-3649		1-1/4	2-3/4	6-1/2	13-5/8	3/8	0	12.75
SFFT90-3653		1-1/2	2-13/16	7	13-3/4	3/8	0	14.25
SFFT90-3658		2	2-3/4	7	14	1/2	0	15.15
SFFT90-4430	1-1/2 - 12	3/4	2	6-7/16	11-13/16	1/8	1	7.25
SFFT90-4439		1	2	6-1/2	11-1/2	7/32	1-1/4	7.75
SFFT90-4449		1-1/4	2-3/4	7	13-1/4	3/8	1-5/8	12.70
SFFT90-4453		1-1/2	2-3/4	7	13-1/2	3/8	0	16.95
SFFT90-4458		2	2-3/4	7	13-5/8	3/8	0	14.25
SFFT90-4460		2-1/2	2-3/4	7	13-5/8	1/2	0	16.35
SFFT90-4462		3	2-3/4	7	13-3/4	1/2	0	18.25
SFFT90-5449	2 - 12	1-1/4	3	6-5/8	7-3/16	3/8	0	21.15
SFFT90-5453		1-1/2	2-13/16	6-5/8	17-3/8	3/8	0	19.25
SFFT90-5458		2	3	6-3/4	16-1/2	1/2	0	23.35
SFFT90-5460		2-1/2	3-1/4	6-3/4	16-1/2	1/2	0	25.65
SFFT90-5462		3	3-1/4	7	16-7/16	5/8	3-1/8	28.65

TYPE SNX

Expansion -
Stud to Flat

All-bronze roller-type flexible stud connector for take-off angles 0° - 90°. This design will support weight of tubular bus while allowing horizontal movement. May be used with bronze or aluminum terminal connector. Laminated copper strap is soldered to form a solid tinned pad at each end.

Casting Alloy: Electrical Bronze
Clamping Hardware: Silicon Bronze
Roller: Stainless Steel
Options: See Page 207

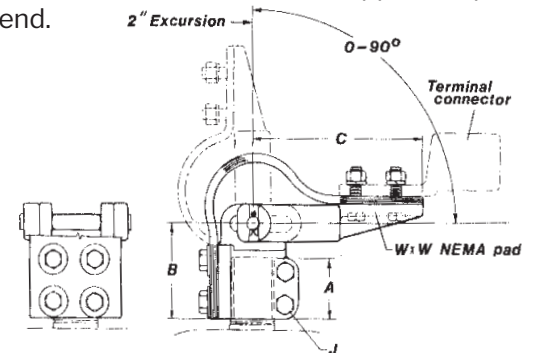

CATALOG NUMBER	STUD DIA./THD.	DIMENSIONS - INCHES					WEIGHT (POUNDS)
		A	B	C	J	W x W	
SNX-27-4A	1 - 14	2-1/8	3-7/8	6-5/8	1/2	3 x 3	16.45
SNX-33-4A	1-1/8 - 12	2-1/8	3-7/8	6-5/8	1/2	3 x 3	16.70
SNX-36-4A	1-1/4 - 12	2-1/8	3-7/8	6-1/2	1/2	3 x 3	17.20
SNX-44-4A	1-1/2 - 12	2-1/8	3-7/8	6-1/2	1/2	3 x 3	17.75
SNX-50-4B	1-3/4 - 12	2-1/2	3-7/8	7-1/4	1/2	4 x 4	26.10
SNX-54-4B	2 - 12	2-1/2	3-7/8	7-1/4	1/2	4 x 4	26.10
SNX-57-4B	2-1/4 - 12	2-1/2	3-7/8	7-1/4	1/2	4 x 4	27.00
SNX-59-4B	2-1/2 - 12	2-1/2	3-7/8	7-1/4	1/2	4 x 4	36.15
SNX-61-4B	3 - 12	3	4-1/2	7-1/4	5/8	4 x 4	36.15

BRONZE STUD CONNECTORS

TYPE SNFT

Bolted
Stud to Flat Pad

All-bronze stud connector for copper stud to flat NEMA pad.
Contact pad is finished on both sides.
Metric options are available for smooth and threaded stud connectors.
Contact factory for details.

Casting Alloy: Electrical bronze
Clamping Hardware: Silicon bronze
Options: See Page 207

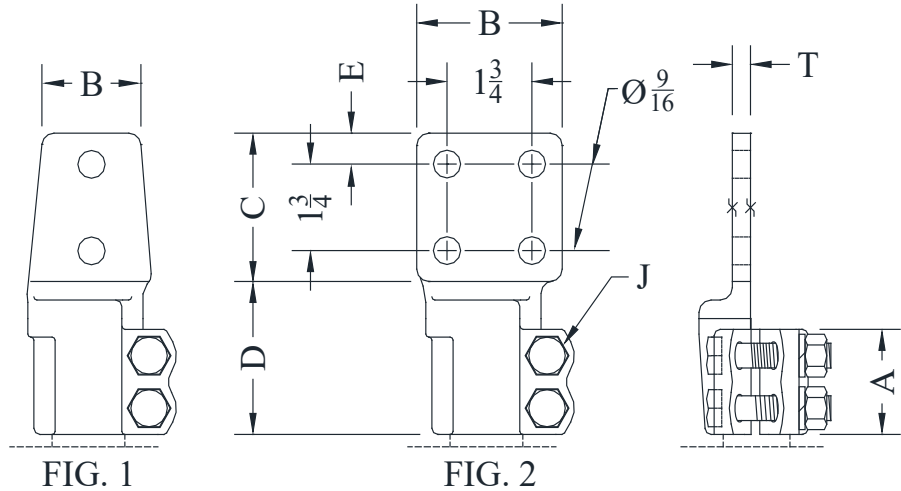

CATALOG NUMBER	STUD DIA. / THD.	FIG. NO.	DIMENSIONS - INCHES							WEIGHT (POUNDS)
			A	B	C	D	E	J	T	
SNFT-14-2B	5/8 - 11	1	1-13/16	2	3	2-7/16	5/8	3/8	1/4	1.45
SNFT-14-4A		2	1-13/16	3	3	2-1/2	5/8	3/8	1/4	2.05
SNFT-18-2B	3/4 - 16	1	1-3/8	2	3	2	5/8	1/2	1/4	1.45
SNFT-18-4A		2	1-13/16	3	3	2-1/2	5/8	3/8	1/4	2.05
SNFT-27-2B	1 - 14	1	2	2	3	2-3/4	5/8	3/8	3/8	2.00
SNFT-27-4A		2	2	3	3	2-7/8	5/8	3/8	3/8	2.95
SNFT-27-4B		2	2	4	4	2-7/8	1-1/8	3/8	3/8	4.00
SNFT-33-2B	1-1/8 - 12	1	2-1/8	2	3	2-7/8	5/8	1/2	3/8	3.40
SNFT-33-4A		2	2-1/8	3	3	3	5/8	1/2	3/8	3.65
SNFT-33-4B		2	2-1/8	4	4	3	1-1/8	1/2	3/8	4.70
SNFT-36-2B	1-1/4 - 12	1	2-1/8	2	3	2-15/16	5/8	1/2	9/16	3.15
SNFT-36-4A		2	2-1/8	3	3	3	5/8	1/2	1/2	3.90
SNFT-36-4B		2	2-1/8	4	4	3	1-1/8	1/2	3/8	5.40
SNFT-44-2B	1-1/2 - 12	1	2-1/8	2	3	2-11/16	5/8	1/2	1/2	3.65
SNFT-44-4A		2	2-1/8	3	3	2-15/16	5/8	1/2	1/2	4.65
SNFT-44-4B		2	2-1/8	4	4	3-1/16	1-1/8	1/2	1/2	5.90
SNFT-50-2B	1-3/4 - 12	1	2-3/8	2	3	3-1/8	5/8	1/2	1/2	6.45
SNFT-50-4A		2	2-3/8	3	3	3-1/8	5/8	1/2	1/2	6.45
SNFT-50-4B		2	2-3/8	4	4	3-5/16	1-1/8	1/2	1/2	7.95
SNFT-54-2B	2 - 12	1	2-7/16	2	3	3-9/16	5/8	1/2	1/2	6.70
SNFT-54-4A		2	2-7/16	3	3	3-9/16	5/8	1/2	1/2	6.70
SNFT-54-4B		2	2-7/16	4	4	3-9/16	1-1/8	1/2	1/2	7.95

BRONZE STUD CONNECTORS

TYPE SNFT (CONTINUED)

CATALOG NUMBER	STUD DIA. / THD.	FIG. NO.	DIMENSIONS - INCHES							WEIGHT (POUNDS)
			A	B	C	D	E	J	T	
SNFT-57-2B	2-1/4 -12	1	2-5/8	2	3	3-11/16	5/8	1/2	3/4	10.50
SNFT-57-4A		2	2-5/8	3	3	3-11/16	5/8	1/2	3/4	10.50
SNFT-57-4B		2	2-5/8	4	4	3-11/16	1-1/8	1/2	3/4	10.50
SNFT-59-4A	2-1/2 - 12	2	2-1/2	3	3	3-1/2	5/8	1/2	3/4	11.05
SNFT-59-4B		2	2-1/2	4	4	3-1/2	1-1/8	1/2	3/4	11.05
SNFT-60-4A	2-7/8 - 12	2	3	3	3	4-1/8	5/8	5/8	3/4	14.50
SNFT-60-4B		2	3	4	4	4-1/8	1-1/8	5/8	3/4	14.50
SNFT-61-4A	3 - 12	2	3-1/8	3	3	4-3/8	5/8	5/8	3/4	13.00
SNFT-61-4B		2	3-1/8	4	4	4-3/8	1-1/8	5/8	13/16	15.40
SNFT-615-4A	3-1/4 - 12	2	3-1/8	3	3	4-1/2	5/8	5/8	3/4	13.25
SNFT-615-4B		2	3-1/8	4	4	4-1/2	1-1/8	5/8	3/4	15.50
SNFT-63-4B	4 - 12	2	3-1/2	4	4	4-11/16	1-1/8	5/8	1	21.35
*SNFT-65-4B	5 - 12	2	4-5/8	4	4	6-1/4	1-1/8	5/8	1	35.85

Type SNFT with 6-hole pads

Type SNFT is available with 6-hole NEMA contact pads for stud diameters of 2 inches and larger. Dimensions, except for pad width, are same as listed for 4-hole pads in table above. Pad size -6A has width (B) of 5 inches. Pad size -6B has width (B) of 6 inches. Specify -6A or -6B pad by substituting either of the two for the -4B in the table above.
Example: SNFT-54-6A

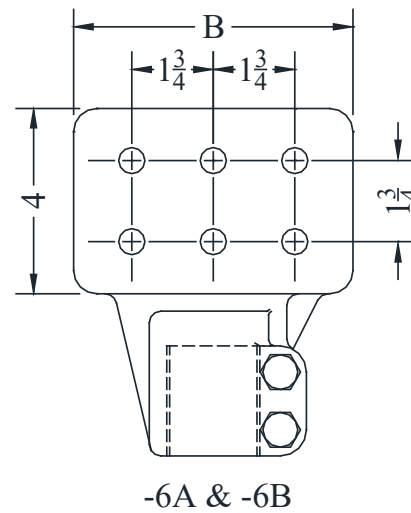

BRONZE STUD CONNECTORS

TYPE SNFT90

Bolted Horizontal

Stud to Flat 90° Pad

All-bronze stud connector for copper stud to flat, horizontal NEMA pad for 90° take-off. Contact pad is finished on side shown.

Metric options available for smooth and threaded stud connectors. Contact factory for details.

Casting Alloy: Electrical Bronze
Clamping Hardware: Silicon Bronze
Options: See Page 207

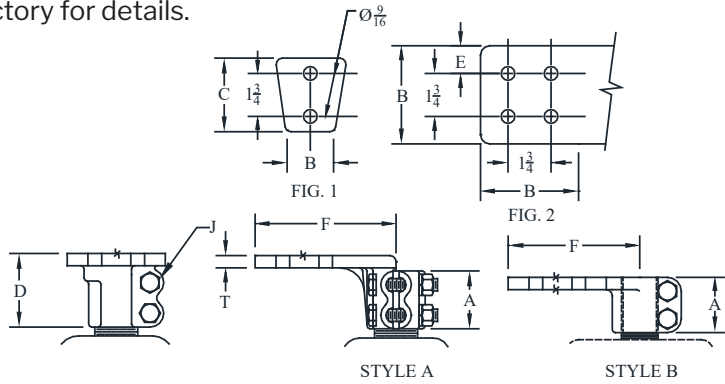

CATALOG NUMBER	STUD DIA. / THD.	FIG. NO.	STYLE	DIMENSIONS - INCHES								WEIGHT (POUNDS)
				A	B	C	D	E	F	J	T	
SNFT90-14-2B	5/8 - 11	1	B	2	2	3	2	5/8	3-3/4	3/8	1/4	1.45
SNFT90-14-4A		2	B	2	3	3	2	5/8	3-3/4	3/8	1/4	1.50
SNFT90-18-2B	3/4 - 16	1	B	2	2	3	2	5/8	3-3/4	1/2	5/16	1.00
SNFT90-18-4A		2	B	2-1/8	3	3	2-1/8	5/8	4	1/2	1/2	2.35
SNFT90-27-2B	1 - 14	1	A	2-1/8	2	3	2-7/8	5/8	4-5/8	1/2	1/2	5.00
SNFT90-27-4A		2	A	2-1/8	3	3	2-7/8	5/8	4-1/8	1/2	1/2	5.00
SNFT90-27-4B		2	A	2-1/8	4	4	2-7/8	1-1/8	4-5/8	1/2	1/2	5.00
SNFT90-33-2B	1-1/8 - 12	1	A	2-1/8	2	3	2-7/8	5/8	4-5/8	1/2	1/2	5.00
SNFT90-33-4A		2	A	2-1/8	3	3	3	5/8	4-1/8	1/2	1/2	5.00
SNFT90-33-4B		2	A	2-1/8	4	4	2-7/8	1-1/8	4-5/8	1/2	1/2	5.00
SNFT90-36-2B	1-1/4 - 12	1	B	2-1/8	2	3	2-1/8	5/8	4	1/2	1/2	6.15
SNFT90-36-4A		2	B	2-1/8	3	3	2-1/8	5/8	4	1/2	1/2	6.15
SNFT90-36-4B		2	B	2-1/8	4	4	2-1/8	1-1/8	5	1/2	1/2	6.15
SNFT90-44-4A	1-1/2 - 12	2	B	2-1/4	3	3	2-1/4	5/8	5-1/4	1/2	1/2	6.90
SNFT90-44-4B		2	A	2-1/8	4	4	2-7/8	1-1/8	4-1/2	1/2	1/2	6.90
SNFT90-44-4B-FF		2	B	2-1/4	4	4	2-1/4	1-1/8	5-3/8	1/2	1/2	6.90
SNFT90-50-4A	1-3/4 - 12	2	A	2-3/8	3	3	3-1/4	5/8	4-3/8	1/2	1/2	8.45
SNFT90-50-4B		2	A	2-3/8	4	4	3-1/4	1-1/8	5-3/4	1/2	1/2	8.45
SNFT90-54-4A	2 - 12	2	A	2-1/2	3	3	3-1/8	5/8	4-7/8	1/2	1/2	7.00
SNFT90-54-4B		2	A	2-1/2	4	4	3-1/8	1-1/8	5-3/8	1/2	1/2	7.00
SNFT90-57-4A	2-1/4 - 12	2	B	2-3/4	3	3	2-5/8	5/8	4-7/8	1/2	1/2	8.75
SNFT90-57-4B		2	B	2-5/8	4	4	2-5/8	1-1/8	5-3/8	1/2	1/2	9.50
SNFT90-59-4A	2-1/2 - 12	2	B	2-5/8	3	3	2-5/8	5/8	4-7/8	1/2	1/2	9.50
SNFT90-59-4B		2	B	2-5/8	4	4	2-5/8	1-1/8	5-3/8	1/2	1/2	9.50
SNFT90-61-4A	3 - 12	2	B	3-1/4	3	3	3-1/4	5/8	5-1/2	5/8	3/4	15.50
SNFT90-61-4B		2	B	3-1/4	4	4	3-1/4	1-1/8	6-1/4	5/8	3/4	15.50
SNFT90-615-4A	3-1/4 - 12	2	B	3-1/4	3	3	3-1/4	5/8	5-1/4	5/8	3/4	15.50
SNFT90-615-4B		2	B	3-1/4	4	4	3-1/4	1-1/8	6-1/4	5/8	3/4	15.50
SNFT90-63-4B	4 - 12	2	B	3-1/4	4	4	3-1/4	1-1/8	6-7/8	5/8	1	20.00

BRONZE STUD CONNECTORS

TYPE SNFV

Bolted Vertical
Stud to Flat 90° Pad

All-bronze stud connector for copper stud to vertical 90° NEMA pad.
Contact pad is finished on both sides.
Metric options available for smooth and threaded stud connectors.
Contact factory for details.

Casting Alloy: Electrical Bronze
Clamping Hardware: Silicon Bronze
Options: See Page 207

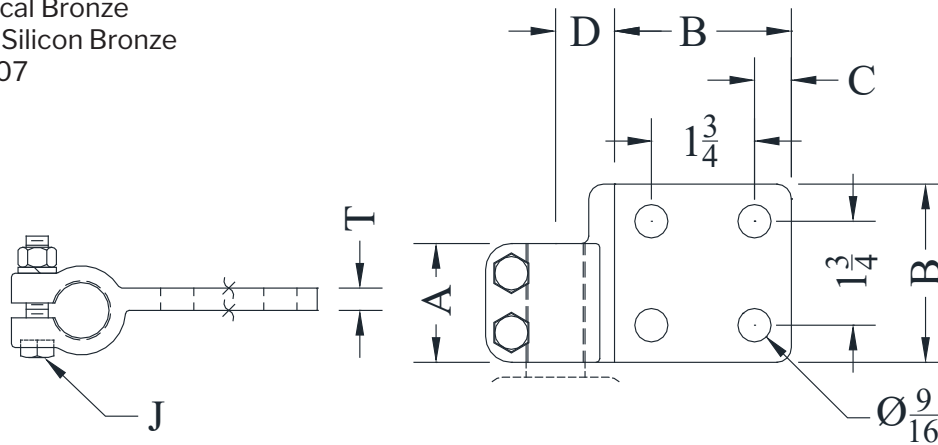

CATALOG NUMBER	STUD DIA./THD.	DIMENSIONS - INCHES						WEIGHT (POUNDS)
		A	B	C	D	J	T	
SNFV-18-4A	3/4 - 16	2	3	5/8	1	3/8	3/8	1.70
SNFV-27-4A	1 - 14	2	3	5/8	1	3/8	3/8	2.30
SNFV-33-4A	1-1/8 - 12	2-1/8	3	5/8	1-1/4	1/2	7/16	3.20
SNFV-33-4B			4	1-1/8	1-1/4	1/2	7/16	4.00
SNFV-36-4A	1-1/4 - 12	2-1/8	3	5/8	1-1/4	1/2	7/16	3.50
SNFV-36-4B			4	1-1/8	1-1/4	1/2	7/16	4.30
SNFV-44-4A	1-1/2 - 12	2-1/8	3	5/8	1-7/16	1/2	7/16	3.60
SNFV-44-4B			4	1-1/8	1-7/16	1/2	7/16	5.20
SNFV-50-4A	1-3/4 - 12	2-3/8	3	5/8	1-1/2	1/2	1/2	4.70
SNFV-50-4B			4	1-1/8	1-1/2	1/2	1/2	6.00
SNFV-54-4A	2 - 12	2-7/16	3	5/8	1-7/8	1/2	3/4	5.70
SNFV-54-4B			4	1-1/8	1-7/8	1/2	3/4	6.80
SNFV-57-4A	2-1/4 - 12	2-1/2	3	5/8	1-7/8	1/2	1/2	6.80
SNFV-57-4B			4	1-1/8	1-7/8	1/2	1/2	7.90
SNFV-59-4A	2-1/2 - 12	2-1/2	3	5/8	1-7/8	1/2	1/2	7.10
SNFV-59-4B			4	1-1/8	2-1/8	1/2	1/2	8.00
SNFV-60-4A	2-7/8 - 12	3	3	5/8	2-1/4	5/8	3/4	11.40
SNFV-60-4B			4	1-1/8	2-3/8	5/8	1	12.30
SNFV-61-4A	3 - 12	3-1/4	3	5/8	2-3/8	5/8	1	13.25
SNFV-61-4B			4	1-1/8	2-3/8	5/8	1	15.50
SNFV-615-4A	3-1/4 - 12	3-1/4	3	5/8	2-1/2	5/8	7/8	14.00
SNFV-615-4B			4	1-1/8	2-1/2	5/8	7/8	16.00
SNFV-63-4B	4 - 12	4	4	1-1/8	3	5/8	1-1/2	28.10

BRONZE STUD CONNECTORS

TYPE STT

Bolted
Stud to Pipe

All-Bronze stud connector for copper stud to standard copper pipe.
For 90° connector, insert STT90 in place of STT in the table below.
Metric options available for smooth and threaded stud connectors.
Contact factory for details.

Casting Alloy: Electrical Bronze
Clamping Hardware: Silicon Bronze
Options: See Page 207

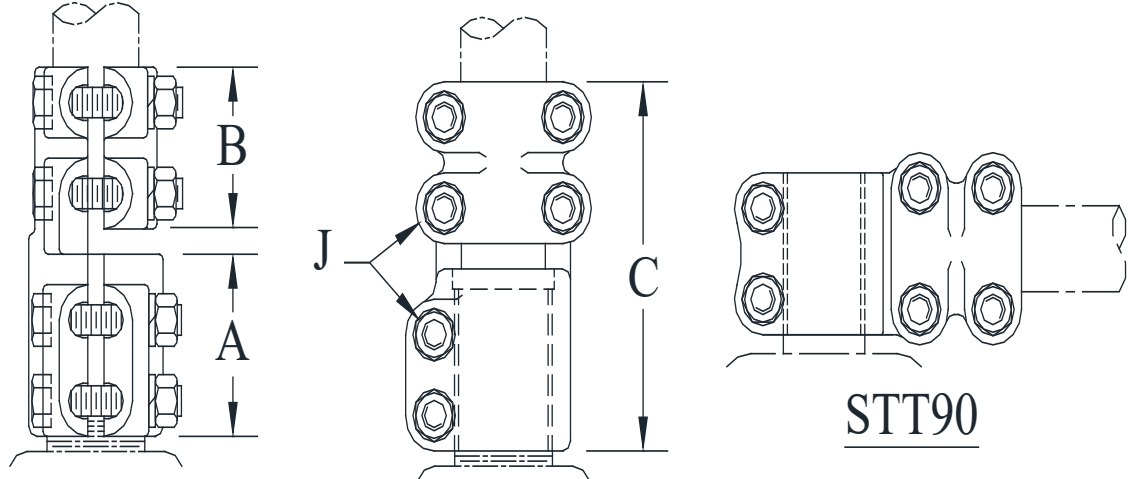

CATALOG NUMBER	STUD DIA./THD.	PIPE SIZE (NPS)	DIMENSIONS - INCHES				WEIGHT (POUNDS)
			A	B	C	J	
STT-1021	1/2 - 13	1/2	CONTACT FACTORY FOR DETAILS				
STT-1030		3/4	1-7/8	2	4	3/8	3.00
STT-1821	3/4 - 16	1/2	CONTACT FACTORY FOR DETAILS				
STT-1830		3/4	1-7/8	2	4	3/8	3.00
STT-1839		1	2	2	4-1/4	3/8	3.65
STT-2730	1 - 14	3/4	2-1/8	3-1/2	6-3/8	1/2	5.70
STT-2739		1	2-1/8	2	4-3/8	3/8	3.15
STT-2749		1-1/4	CONTACT FACTORY FOR DETAILS				
STT-2753		1-1/2	2-1/8	2-3/4	5-5/8	1/2	6.05
STT-3330	1-1/8 - 12	3/4	2-1/8	2-3/8	5-5/16	3/8	5.60
STT-3339		1	2-1/8	2	4-1/4	3/8	6.15
STT-3349		1-1/4	2-1/4	2-3/4	5-5/8	1/2	6.00
STT-3353		1-1/2	2-5/8	2-3/4	5-1/2	1/2	5.85
STT-3358		2	2-7/8	3	5-7/8	1/2	7.00
STT-3360		2-1/2	2-1/8	3	5-3/4	1/2	8.90
STT-3630	1-1/4 - 12	3/4	2-1/4	4-1/4	7-1/16	1/2	4.85
STT-3639		1	CONTACT FACTORY FOR DETAILS				
STT-3649		1-1/4	2-3/4	2-3/4	5-5/8	1/2	5.95
STT-3653		1-1/2	2-1/2	2-3/4	5-3/8	1/2	6.35
STT-3658		2	2-3/4	3	5-7/8	1/2	7.55
STT-3660		2-1/2	CONTACT FACTORY FOR DETAILS				

BRONZE STUD CONNECTORS

TYPE STT Continued

CATALOG NUMBER	STUD DIA./THD.	PIPE SIZE (NPS)	DIMENSIONS - INCHES				WEIGHT (POUNDS)
			A	B	C	J	
STT-4430	1-1/2 - 12	3/4	1-3/4	2	4-3/8	3/8	5.50
STT-4439		1	2-1/4	2	4-9/16	3/8	3.40
STT-4449		1-1/4	2-3/4	2-3/4	5-5/8	1/2	6.30
STT-4453		1-1/2	2-1/8	2-13/16	5-1/2	1/2	6.55
STT-4458		2	2-3/4	3	5-7/8	1/2	7.60
STT-4460		2-1/2	CONTACT FACTORY FOR DETAILS				
STT-5439		2 - 12	1	CONTACT FACTORY FOR DETAILS			
STT-5449	1-1/4		2-3/8	2-3/4	6	1/2	10.65
STT-5453	1-1/2		CONTACT FACTORY FOR DETAILS				
STT-5458	2						
STT-5460	2-1/2						
STT-5949	1-1/4						
STT-5953	1-1/2						
STT-5958	2						
STT-5960	2-1/2						
STT-5962	3						
STT-6149	3 - 12	1-1/4	CONTACT FACTORY FOR DETAILS				
STT-6153		1-1/2					
STT-6158		2					
STT-6160		2-1/2					
STT-6162		3	2-3/4	3-1/4	6-11/16	5/8	19.00

BRONZE STUD CONNECTORS

TYPE SXR/SXR2

Bolted

Stud to One or Two Cables

An alternative bolt-up type stud to one or two cables, with reversible caps for a wide range of cable, straight-on, or 90° to stud.

Metric options available for smooth and threaded stud connectors.

Contact factory for details.

Casting Alloy: Electric Bronze
Clamping Hardware: Silicon Bronze
Options: See Page 207

Aluminum version also available see ASXR/ASXR2: PAGE 205

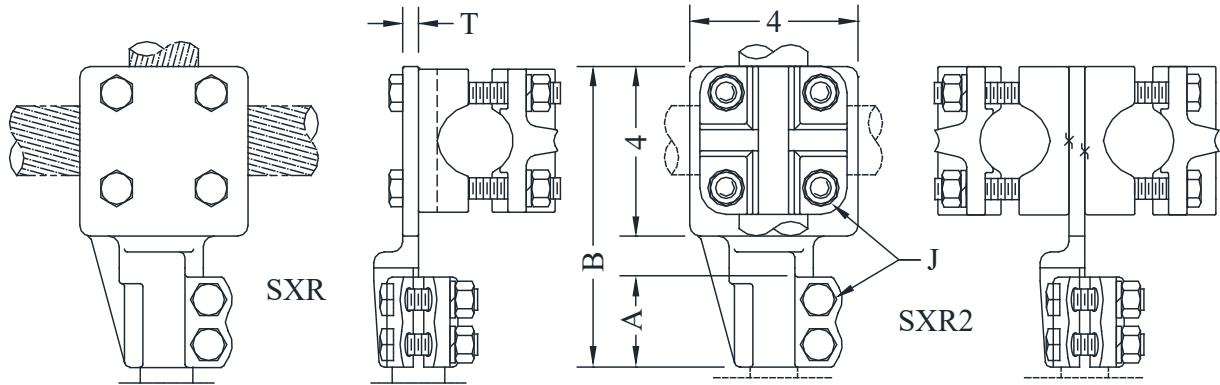

CATALOG NUMBER	STUD IN./THD.	CONDUCTOR RANGE	DIMENSIONS - INCHES				WEIGHT (POUNDS)
			A	B	J	T	
SXR-3348	1-1/8 - 12	#2 - 2000 MCM	2-1/8	7	1/2	3/8	10.80
SXR2-3348		(2) #2 - 2000 MCM					16.35
SXR-3648	1-1/4 - 12	#2 - 2000 MCM	2-1/8	7-1/8	1/2	3/8	11.55
SXR2-3648		(2) #2 - 2000 MCM					17.05
SXR-4448	1-1/2 - 12	#2 - 2000 MCM	2-1/8	7-1/16	1/2	1/2	12.05
SXR2-4448		(2) #2 - 2000 MCM					17.60
SXR-5048	1-3/4 - 12	#2 - 2000 MCM	2-3/8	7-5/16	1/2	1/2	14.00
SXR2-5048		(2) #2 - 2000 MCM					19.60
SXR-5448	2 - 12	#2 - 2000 MCM	2-7/16	7-9/16	1/2	1/2	14.10
SXR2-5448		(2) #2 - 2000 MCM					19.60
SXR-5748	2-1/4 - 12	#2 - 2000 MCM	2-5/8	7-11/16	1/2	3/4	16.70
SXR2-5748		(2) #2 - 2000 MCM					22.15
SXR-5948	2-1/2 - 12	#2 - 2000 MCM	2-1/2	7-1/2	1/2	3/4	17.20
SXR2-5948		(2) #2 - 2000 MCM					22.95
SXR-6148	3 - 12	#2 - 2000 MCM	3-1/8	8-3/8	1/2 - 5/8	3/4	21.65
SXR2-6148		(2) #2 - 2000 MCM					27.20
SXR-6348	4 - 12	#2 - 2000 MCM	3-1/2	8-3/4	1/2 - 5/8	1	27.60
SXR2-6348		(2) #2 - 2000 MCM					33.25

BRONZE STUD CONNECTORS

TYPE SXT

Bolted Expansion
Stud to Pipe

Casting Alloy: Electrical Bronze
Clamping Hardware: Silicon Bronze
Options: See Page 207

All-bronze expansion stud connector for copper stud to standard copper pipe.
Alignment guide accommodates standard or extra-heavy pipe.
Normally furnished with laminated copper straps.
For 90° connection, substitute SXT90 in table below.
Add suffix (H) for SCH 80 pipe.
Example: SXT-4458H
Metric options available for smooth and threaded stud connectors.
Contact factory for details.

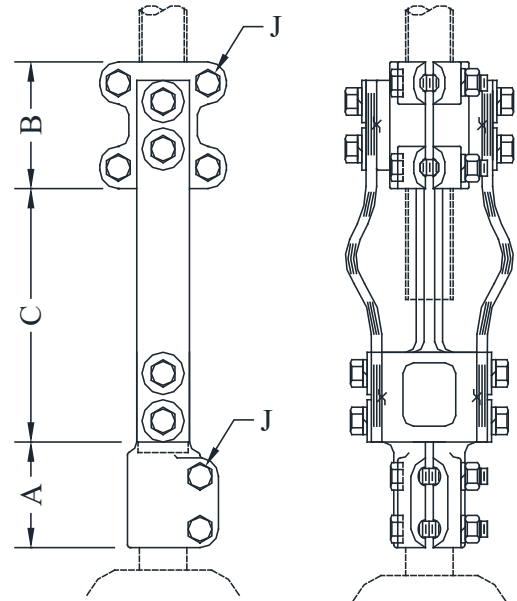
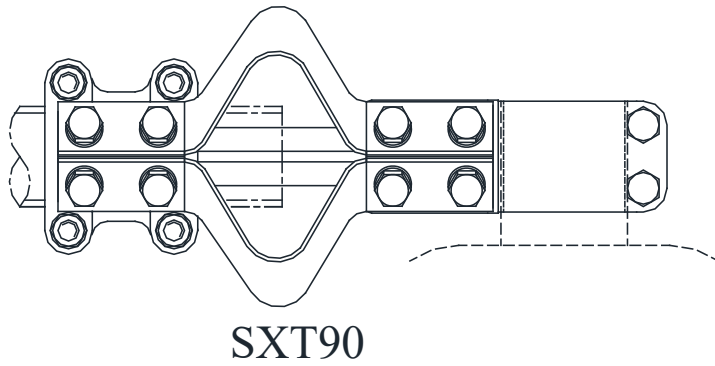

CATALOG NUMBER	STUD DIA./THD.	PIPE SIZE (NPS)	STRAPS	DIMENSIONS - INCHES				WEIGHT (POUNDS)
				A	B	C	J	
SXT-2730	1 - 14	3/4	2	2-1/8	3	6	3/8	7.35
SXT-2739		1	2	2-1/2	3	7-1/2	3/8	9.35
SXT-2749		1-1/4	2	2-1/4	3-1/2	6-1/4	1/2	12.25
SXT-2753		1-1/2	2	2-1/4	3-1/2	6-1/4	1/2	16.55
SXT-3330	1-1/8 - 12	3/4	2	2-1/8	3	6	3/8	9.35
SXT-3339		1	2	4-5/8	3	3-7/8	3/8	10.60
SXT-3349		1-1/4	2	2-3/8	3-1/2	8-1/2	1/2	15.15
SXT-3353		1-1/2	2	2-3/8	3-1/2	8-1/2	1/2	18.65
SXT-3358		2	4	2-7/8	3-1/2	8	1/2	19.45
SXT-3630	1-1/4 - 12	3/4	2	2-3/4	3	4-3/4	3/8	10.45
SXT-3639		1	2	2-3/4	3	4-3/4	3/8	12.10
SXT-3649		1-1/4	2	2-1/4	3-1/2	8-1/2	1/2	14.30
SXT-3653		1-1/2	2	2-1/4	3-1/2	8-1/2	1/2	16.35
SXT-3658		2	4	2-1/4	3-1/2	8-1/2	1/2	18.25

Continued on next page

BRONZE STUD CONNECTORS

TYPE SXT Continued

CATALOG NUMBER	STUD DIA./THD.	PIPE SIZE (NPS)	NO. STRAPS	DIMENSIONS - INCHES				WEIGHT (POUNDS)
				A	B	C	J	
SXT-4430	1-1/2 - 12	3/4	2	2-1/2	3	4-1/2	3/8	9.00
SXT-4439		1	2	2-1/2	3	4-3/4	3/8	11.85
SXT-4449		1-1/4	2	2-1/8	2-1/2	11-11/16	1/2	18.20
SXT-4453		1-1/2	2	2-1/2	2-1/2	5	1/2	18.25
SXT-4458		2	4	2-1/8	3-1/2	9-1/4	1/2	22.30
SXT-4460		2-1/2	4	2-1/8	4	9	1/2	23.75
SXT-4462		3	4	2-3/4	4	9-5/8	1/2	28.70
SXT-5449	2 - 12	1-1/4	2	2-7/16	2-1/2	11-1/2	1/2	21.25
SXT-5453		1-1/2	2	2-7/16	3-1/2	12-3/16	1/2	23.60
SXT-5458		2	4	2-3/4	3-1/2	7	1/2	23.25
SXT-5460		2-1/2	4	2-3/4	4	9	1/2	26.10
SXT-5462		3	4	2-7/16	3	14-9/16	1/2	47.90
SXT-5958	2-1/2 - 12	2	4	2-3/4	3-1/2	9	1/2	27.55
SXT-5960		2-1/2	4	2-7/8	4	9	1/2	29.80
SXT-5962		3	4	2-3/4	3	9	1/2	31.20
SXT-6158	3 - 12	2	4	3-1/8	2-1/2	9	1/2	44.55
SXT-6160		2-1/2	2	3-1/8	3-3/4	16-5/8	1/2	48.35
SXT-6162		3	4	3	4	6	5/8	43.85
SXT-6163		3-1/2	4	3	4	6	5/8	54.10
SXT-6164		4	6	3	4	10-1/4	5/8	68.45
SXT-6262	3-1/2 - 12	3	CONTACT FACTORY FOR DETAILS					
SXT-6264		4						
SXT-6362	4 - 12	3	CONTACT FACTORY FOR DETAILS					
SXT-6364		4						

EHV STUD CONNECTORS



ASNFHV



ASNF2HV



ASN3HV



AS3N90

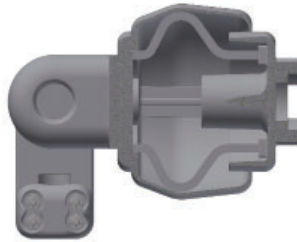

WSXTRHV



WSXHV

SEFCOR EHV stud connectors are corona-free for 345kV and 500kV applications. Both with high-voltage laboratory testing and with years of time-proven trouble-free operating service, our EHV stud connectors attest to the superiority of the SEFCOR designs.

Metric options available for smooth and threaded stud connectors.
Contact factory for details.

All aluminum castings are poured from 356 aluminum alloy and heat-treated to T6 temper. Bronze castings are high quality electrical bronze in accordance with ASTM-B145.
This section is arranged in the following sequence for the convenience of the user:

**STUD TO FLAT PAD
STUD TO CABLE
STUD TO PIPE**

OPTIONS

A suffix added to catalog number denotes a variation or option made to the standard cataloged item. The suffixes listed below display the various options available with SEFCOR EHV stud connectors. Consult manufacturer for further details, unlisted and/or special applications.

- A () Factory-set angle, (i.e.; A45, provides for a 45° angle)
- H Heavy (extra-thickness contact pad)
- HS Supplied with hardware shields
- SP Special requirement, refer to factory
- SS Stainless steel hardware instead of standard hardware
- TØ Smooth stud bore - no threads
- T () Special stud threads, (i.e.; T14, provides 14 threads per inch)

EHV STUD CONNECTORS

TYPE ASNFHV

Aluminum or Bronze Bolted
Stud to Flat Pad

TYPE ASNFHV

Casting Alloy: 356-T6 Aluminum
Clamping Hardware: Stainless Steel
Options: See Page 227

TYPE ASNFHV-BR

Casting Alloy: Electrical Bronze
Clamping Hardware: Silicon Bronze
Contact Pad: Tinned Both Sides
Options: See Page 227

Note: Pad mounting hardware and hardware shields must be ordered separately when required.

Use shield AA-1094 for in-line or AA-1207 for 90° angle.

Type ASNFHV is designed for corona-free service at 345-500kV when conductor tap is made in-line with the stud on EHV bushings. For conductor taps at 90° to stud, this fitting can be used at 345kV maximum, provided that 90° hardware shields AA-1207 are used at the pad connection.

Metric options available for smooth and threaded stud connectors.
Contact factory for details.

Aluminum contact threads are coated with a sealant, and fittings are shipped in clear plastic bags. Also available with 90° pad orientation

EXAMPLE: ASNFHV90-44-4B

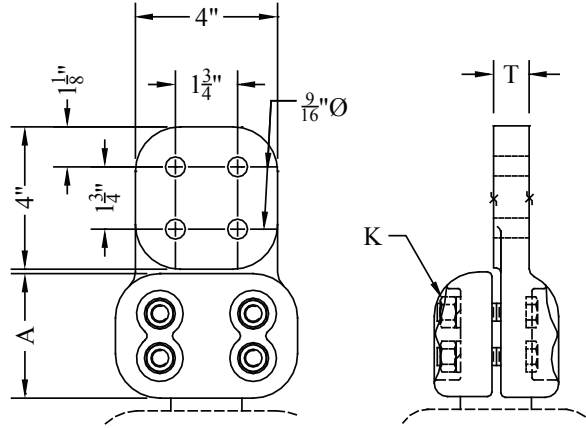

CATALOG NUMBER	STUD DIA./THD.	DIMENSIONS - INCHES			WEIGHT (POUNDS)
		A	T	K	
ASNFHV-33-4B	1-1/8 - 12	3-1/2	3/4	1/2	3.10
ASNFHV-36-4B	1-1/4 - 12	3-1/2	1	1/2	3.25
ASNFHV-44-4B	1-1/2 - 12	3-1/2	1	1/2	5.10
ASNFHV-50-4B	1-3/4 - 12	3-1/2	1	1/2	5.30
ASNFHV-54-4B	2 - 12	3-1/2	1	1/2	5.50
ASNFHV-57-4B	2-1/4 - 12	3-1/2	1	5/8	5.70
ASNFHV-59-4B	2-1/2 - 12	3-1/2	1	5/8	6.00
ASNFHV-61-4B	3 - 12	3-1/2	1	5/8	6.25
ASNFHV-62-4B	3-1/2 - 12	4	1-1/8	5/8	6.50
ASNFHV-63-4B	4 - 12	4	1-1/8	5/8	6.75
ASNFHV-33-4B-BR	1-1/8 - 12	3-1/2	3/4	1/2	9.40
ASNFHV-36-4B-BR	1-1/4 - 12	3-1/2	1	1/2	9.75
ASNFHV-44-4B-BR	1-1/2 - 12	3-1/2	1	1/2	16.60
ASNFHV-50-4B-BR	1-3/4 - 12	3-1/2	1	1/2	17.20
ASNFHV-54-4B-BR	2 - 12	3-1/2	1	1/2	18.00
ASNFHV-57-4B-BR	2-1/4 - 12	3-1/2	1	5/8	19.10
ASNFHV-59-4B-BR	2-1/2 - 12	3-1/2	1	5/8	20.50
ASNFHV-61-4B-BR	3 - 12	3-1/2	1	5/8	22.00
ASNFHV-62-4B-BR	3-1/2 - 12	4	1-1/8	5/8	22.50
ASNFHV-63-4B-BR	4 - 12	4	1-1/8	5/8	27.00

EHV STUD CONNECTORS

TYPE ASNF2HV

Bifurcating
Stud to Flat Pad

Casting Alloy: 356-T6 Aluminum
Stud Hardware: Stainless Steel
Pad Hardware: Aluminum with stainless steel Belleville washers
Options: See Page 227

Type ASNF2HV is designed for corona-free service at 500kV when used with EHV compression terminals to form a bifurcating stud-to-cable connection. Take-off angle A is factory-set at the specified angle. The required angle ($0^\circ - 90^\circ$) is to be inserted within the parenthesis to complete the catalog number.

Metric options available for smooth and threaded stud connectors. Contact factory for details.

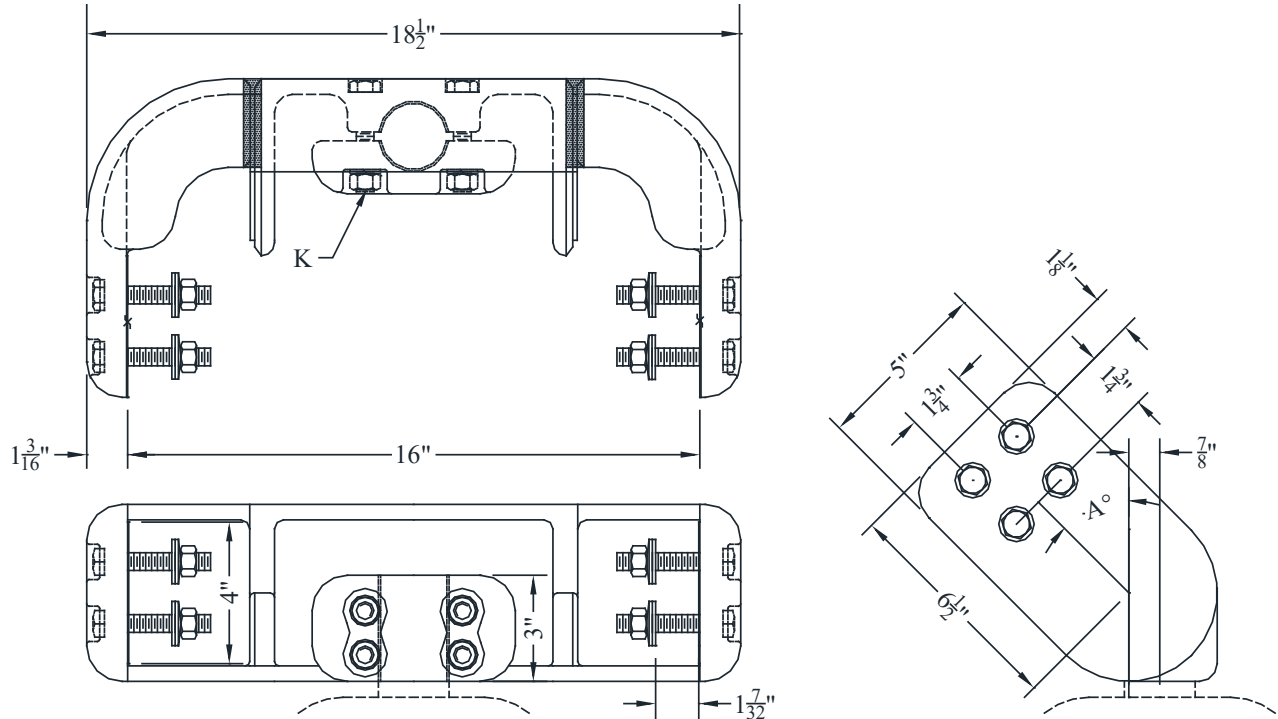

CATALOG NUMBER	STUD DIA./THD.	DIMENSIONS - INCHES		WEIGHT (POUNDS)
		K		
ASNF2HV-33-A ()	1-1/8 - 12	1/2		14.40
ASNF2HV-36-A ()	1-1/4 - 12	1/2		14.50
ASNF2HV-44-A ()	1-1/2 - 12	1/2		18.00
ASNF2HV-50-A ()	1-3/4 - 12	1/2		18.00
ASNF2HV-54-A ()	2 - 12	1/2		15.50
ASNF2HV-57-A ()	2-1/4 - 12	5/8		16.00
ASNF2HV-59-A ()	2-1/2 - 12	5/8		16.40
ASNF2HV-61-A ()	3 - 12	5/8		18.55
ASNF2HV-62-A ()	3-1/2 - 12	5/8		18.00

EHV STUD CONNECTORS

TYPE ASN3HV

Trifurcating
Stud to Cable

Casting Alloy: 356-T6 Aluminum
Stud Hardware: Stainless Steel
Options: See Page 227

Type ASN3HV is designed for corona-free service at 500kV when used with EHV compression terminals to form a trifurcating stud-cable connection. Take-off angle A is factory-set to the specified angle (45° - 90°). The value of the required angle is to be inserted within the parenthesis to form the catalog number. Aluminum contact surfaces are factory-coated with a sealant. Metric options available for smooth and threaded stud connectors. Contact factory for details.

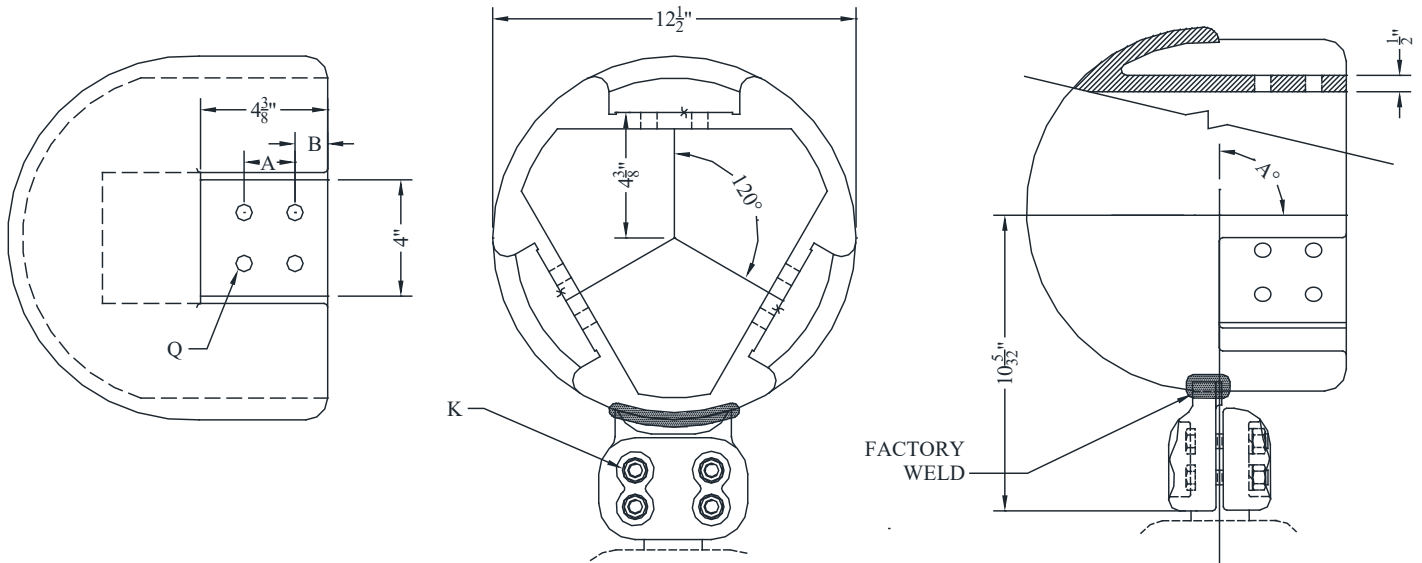

CATALOG NUMBER	STUD DIA./THD.	DIMENSIONS - INCHES				WEIGHT (POUNDS)
		A	B	K	Q	
ASN3HV-33-A ()	1-1/8 - 12	1-3/4	1-1/8	1/2	9/16	37.50
ASN3HV-36-A ()	1-1/4 - 12	1-3/4	1-1/8	1/2	9/16	37.75
ASN3HV-44-A ()	1-1/2 - 12	1-3/4	1-1/8	1/2	9/16	40.00
ASN3HV-50-A ()	1-3/4 - 12	1-3/4	1-1/8	1/2	9/16	38.25
ASN3HV-54-A ()	2 - 12	1-3/4	1-1/8	1/2	9/16	37.25
ASN3HV-57-A ()	2-1/4 - 12	1-3/4	1-1/8	5/8	9/16	39.00
ASN3HV-59-A ()	2-1/2 - 12	1-3/4	1-1/8	5/8	9/16	39.25
ASN3HV-61-A ()	3 - 12	1-3/4	1-1/8	5/8	9/16	39.70
ASN3HV-62-A ()	3-1/2 - 12	1-3/4	1-1/8	5/8	9/16	39.75

EHV STUD CONNECTORS

TYPE AS3N90

90° Trifurcating
Stud to Cable

Stud Connection: Electrical Bronze
Trifurcating Bell: 356-T6 Aluminum
Stud Hardware: Silicon Bronze
Connection Hardware: Stainless Steel
Options: See Page 227

Type AS3N90 is designed for corona-free service at 500kV when used with three EHV compression terminals to form a 90° trifurcating stud-to-cable connection. See Compression Connector section for cable sizes available. Stud clamp is all-bronze with tinned pad. Aluminum contact surfaces are factory-coated with a sealant. Metric options available for smooth and threaded stud connectors. Contact factory for details.

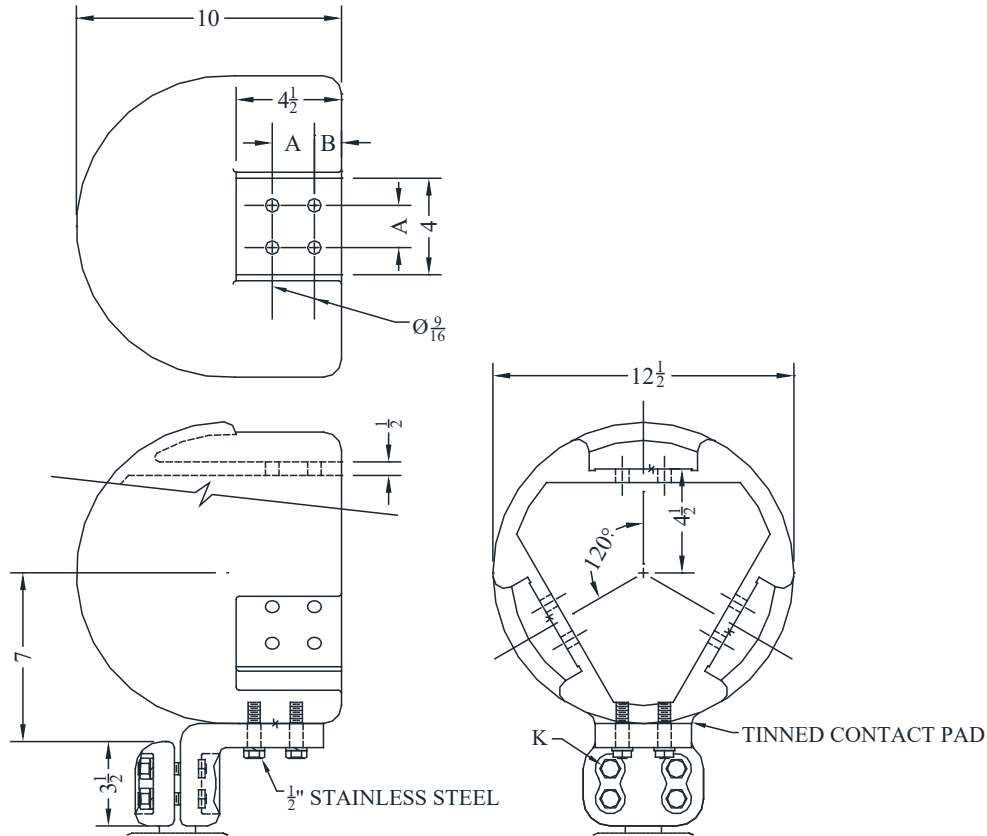

CATALOG NUMBER	STUD DIA./THD.	DIMENSIONS - INCHES			WEIGHT (POUNDS)
		A	B	K	
AS3N90-33	1-1/8 - 12	1-3/4	1-1/8	1/2	37.75
AS3N90-36	1-1/4 - 12	1-3/4	1-1/8	1/2	38.00
AS3N90-44	1-1/2 - 12	1-3/4	1-1/8	1/2	52.15
AS3N90-50	1-3/4 - 12	1-3/4	1-1/8	1/2	38.50
AS3N90-54	2 - 12	1-3/4	1-1/8	1/2	52.15
AS3N90-57	2-1/4 - 12	1-3/4	1-1/8	1/2	39.00
AS3N90-59	2-1/2 - 12	1-3/4	1-1/8	1/2	39.25
AS3N90-61	3 - 12	1-3/4	1-1/8	5/8	39.75
AS3N90-62	3-1/2 - 12	1-3/4	1-1/8	5/8	40.00

EHV STUD CONNECTORS

TYPE WSXTRHV

Weld Expansion
Stud To Pipe

Casting Alloy: 356 Aluminum
Laminated straps: 1100-O Aluminum
Stud Hardware: Stainless Steel
Connection Hardware: Aluminum
Options: See Page 227

Type WSXTRHV is designed for corona-free service at 345kV Angle A is factory-set at the required take-off angle ($0^\circ - 90^\circ$). The value of the required angle is to be inserted within the parenthesis to complete the catalog number. Metric options available for smooth and threaded stud connectors. Contact factory for details.

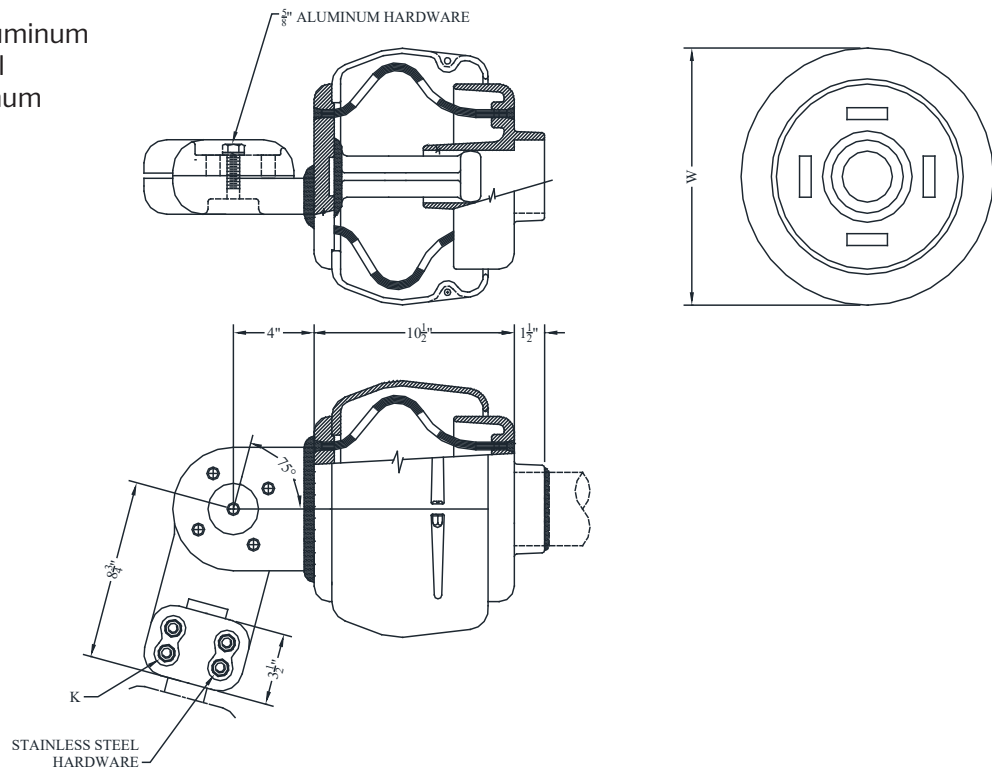

CATALOG NUMBER	STUD DIA./THD.	PIPE SIZE (NPS)	CURRENT CAPACITY	DIMENSIONS - INCHES		WEIGHT (POUNDS)
				W	K	
WSXTRHV-4462-A ()	1-1/2 - 12	3	2000 A	12-1/2	1/2	45.20
WSXTRHV-4464-A ()		4				39.50
WSXTRHV-5464-A ()	2 - 12	4	2000 A	12-1/2	1/2	47.10
WSXTRHV-5467-A ()		5				47.10
WSXTRHV-5469-A ()		6				47.85
WSXTRHV-5764-A ()	2-1/4 - 12	4	2500 A	12-1/2	5/8	44.55
WSXTRHV-5767-A ()		5				40.50
WSXTRHV-5964-A ()	2-1/2 - 12	4	3000 A	12-1/2	5/8	40.25
WSXTRHV-5967-A ()		5				40.75
WSXTRHV-5969-A ()		6				41.25
WSXTRHV-6164-A ()	3 - 12	4	3000 A	12-1/2	5/8	40.50
WSXTRHV-6167-A ()		5				41.00
WSXTRHV-6169-A ()		6				41.50
WSXTRHV-6264-A ()	3-1/2 - 12	4	3000 A	12-1/2	5/8	40.75
WSXTRHV-6267-A ()		5				41.25
WSXTRHV-6269-A ()		6				41.75

EHV STUD CONNECTORS

TYPE WSXH_V

Weld Expansion
Stud To Pipe

Casting Alloy: 356-T6 Aluminum
Laminated straps: 1100-0 Aluminum
Stud Hardware: Stainless Steel
Options: See Page 227

Type WSXH_V is designed for corona-free service at 500kV. Angle A is factory-set at the required take-off angle (0° - 45°). The value of the required angle is to be inserted within the parenthesis to complete the catalog number. Metric options available for smooth and threaded stud connectors. Contact factory for details.

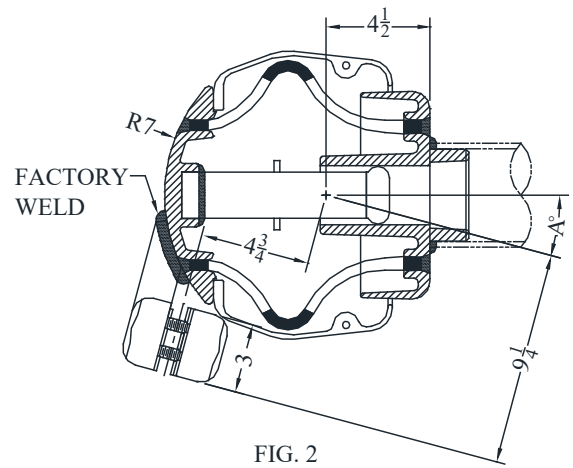
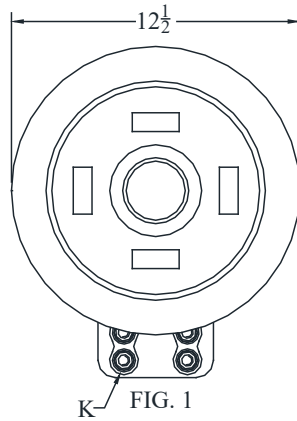
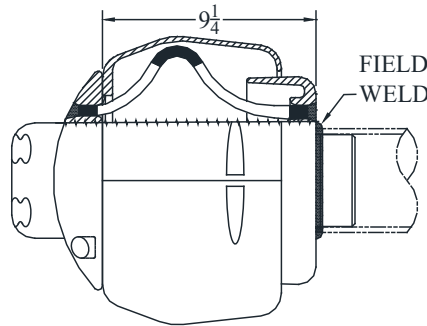

CATALOG NUMBER	STUD DIA./THD.	PIPE SIZE (NPS)	FIG. NO.	CURRENT CAPACITY	K	WEIGHT (POUNDS)
WSXH _V -3363-R()	1-1/8 - 12	3-1/2	1	2000 A	1/2	30.25
WSXH _V -3364-R()		4	2			30.75
WSXH _V -4464-R()	1-1/2 - 12	4	2	2000 A	1/2	29.79
WSXH _V -4467-R()		5				29.57
WSXH _V -5064-R()	1-3/4 - 12	4	2	2000 A	1/2	31.25
WSXH _V -5067-R()		5				31.75
WSXH _V -5464-R()	2 - 12	4	2	2000 A	1/2	29.81
WSXH _V -5467-R()		5			1/2	32.25
WSXH _V -5469-R()		6			5/8	32.75
WSXH _V -5764-R()	2-1/2 - 12	4	2	2500 A	5/8	32.25
WSXH _V -5767-R()		5				32.75
WSXH _V -5769-R()		6				33.25
WSXH _V -6164-R()	3 - 12	4	2	3000 A	5/8	32.50
WSXH _V -6167-R()		5				33.00
WSXH _V -6169-R()		6				33.50

ALUMINUM, BRONZE & EHV

MISCELLANEOUS

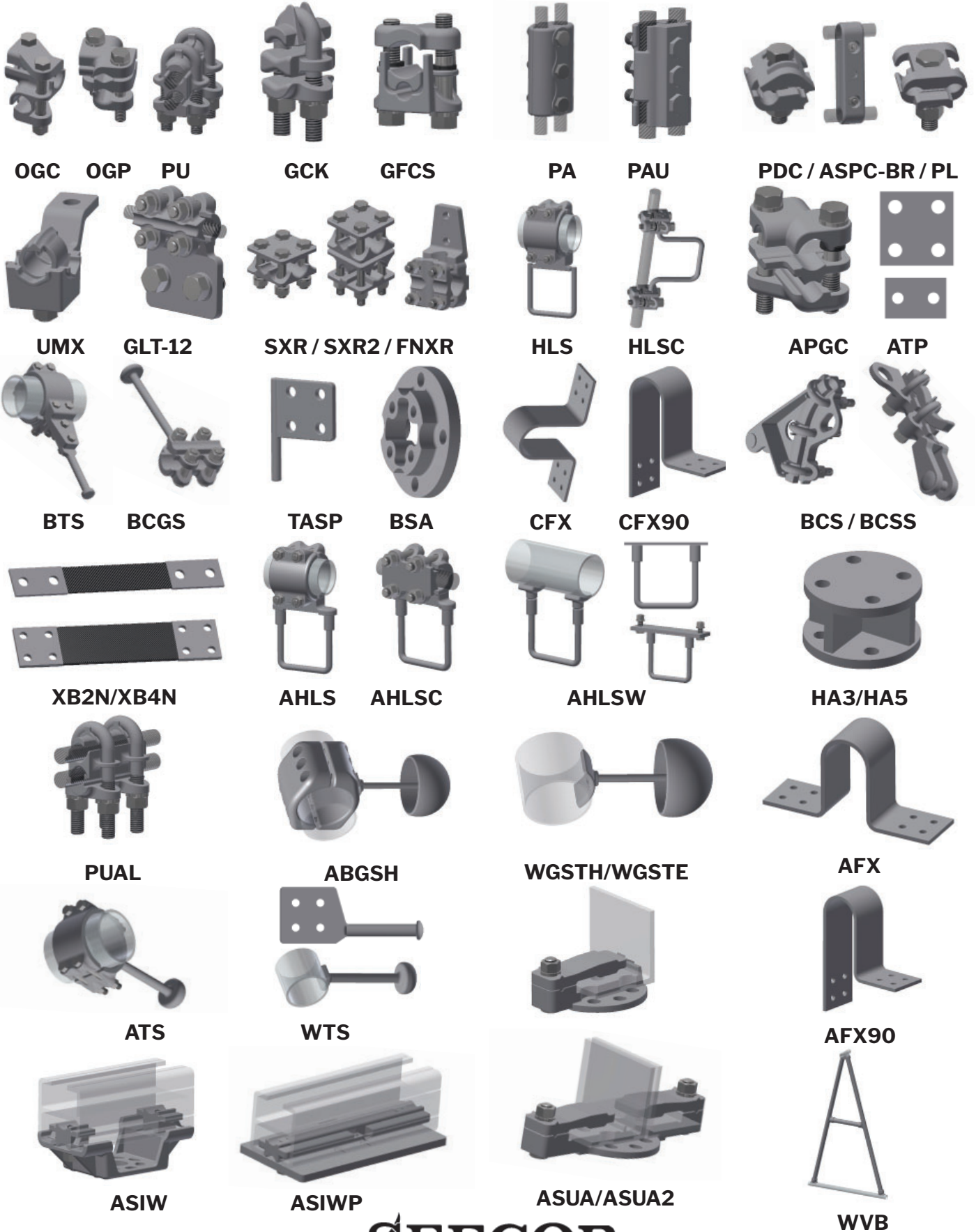

ALUMINUM MISCELLANEOUS

AA-1156 & AA-1467

Horizontal Bifurcating
Flat to Flat

Casting Alloy: 356-T6 Aluminum

Aluminum alloy bifurcating terminal adapter.
Designed for corona-free service at 500kV when used with hardware shields.
Hardware shields are not included with these catalog numbers.

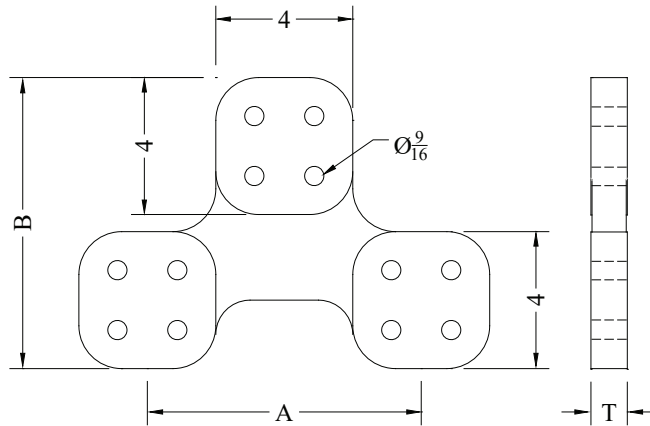

CATALOG NUMBER	DIMENSIONS - INCHES			WEIGHT (POUNDS)
	A	B	T	
AA-1156	4-1/8	8-1/2	1	4.25
AA-1467	8	8-1/2	1	6.50

TYPE BSA

Bolt Circle
Height Adapter

Bronze or aluminum bolt circle and/or height adapter.
Consult manufacturer for further details or unlisted applications.
Add suffix: “-BR” for bronze or
“-AL” for aluminum.

Casting Alloy: Electrical Bronze or 356-T6 Aluminum

CATALOG NUMBER	BOLT CIRCLE	HEIGHT
BSA-5-3	5" to 3"	1-7/16
BSA-7-5	7" to 5"	1-1/4
BSA3-3-5	5" to 3"	3

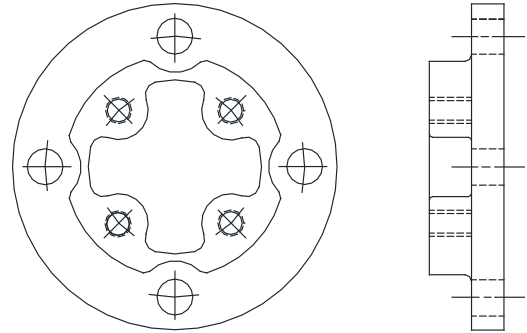

TYPE HA3/HA5

Insulator Height Adapter

Height adapter that can be made from aluminum alloy or galvanized steel and used for either bronze or aluminum applications.
Adapters are custom made to specifications.
Consult manufacturer for further details or unlisted applications.

Material: 356-T Aluminum or Galvanized Steel

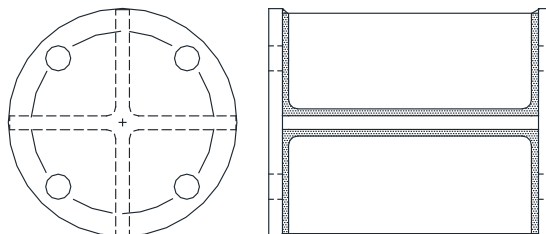

ALUMINUM MISCELLANEOUS

TYPE AFX

Flex Bolted
Flat to Flat

Laminated Strap Material: Aluminum

Aluminum laminated flex connector generally used between bushing terminals and rigid bus. Pad holes have NEMA spacing. Contact sealant recommended between laminations and on contact surfaces. Not recommended as a support member. Also available with other pad sizes and amperage ratings. Consult manufacturer for further details or unlisted applications.

CATALOG NUMBER	FIG. NO.	A (INCHES)	AMPS (INDOOR)
AFX-2B-2	1	2	600
AFX-4A-2	2	3	800
AFX-4A-3	2	3	1200
AFX-4B-2	2	4	1100
AFX-4B-3	2	4	1400
AFX-4B-4	2	4	1600
AFX-4B-6	2	4	2000

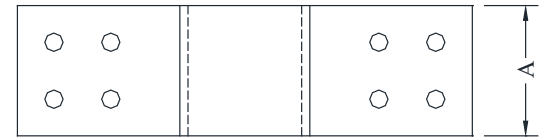
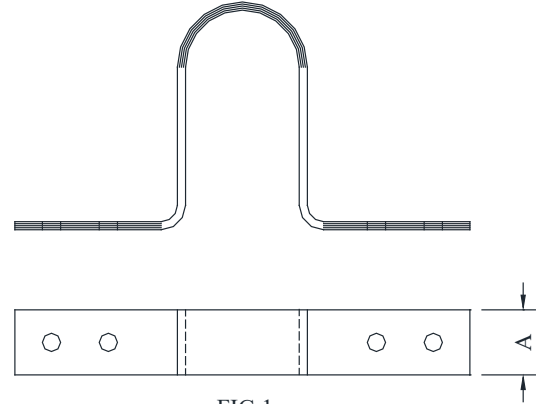

FIG 2

TYPE AFX90

Flex Bolted
Flat to 90° Flat

Laminated Strap Material: Aluminum

Aluminum laminated flex connector generally used between bushing terminals and rigid bus. Pad holes have NEMA spacing. Contact sealant recommended between laminations and on contact surfaces. Not recommended as a support member. Also available with other pad sizes and amperage ratings. Consult manufacturer for further details or unlisted applications.

CATALOG NUMBER	FIG. NO.	A (INCHES)	AMPS (INDOOR)
AFX90-2B-2	1	2	750
AFX90-4A-2	2	3	850
AFX90-4A-3	2	3	1200
AFX90-4B-2	2	4	1100
AFX90-4B-3	2	4	1300
AFX90-4B-4	2	4	1600
AFX90-4B-6	2	4	2200

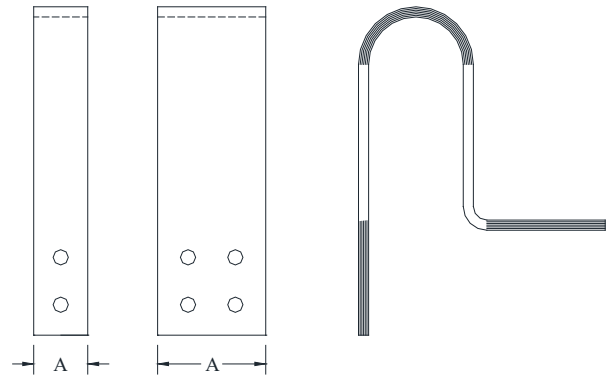

FIG 1

FIG 2

ALUMINUM MISCELLANEOUS

TYPE AHLS

Straight Bolted
Pipe to Stirrup

Aluminum stirrup clamp for ground connections to aluminum pipe.
Contact sealant is recommended.

Casting Alloy: 356-T6 Aluminum
Clamping Hardware: Aluminum Alloy
Stirrup: Tinned Copper

CATALOG NUMBER	CONDUCTOR SIZE (NPS)
AHLS-39	1
AHLS-53	1-1/2
AHLS-58	2
AHLS-60	2-1/2
AHLS-62	3
AHLS-63	3-1/2
AHLS-64	4
AHLS-67	5

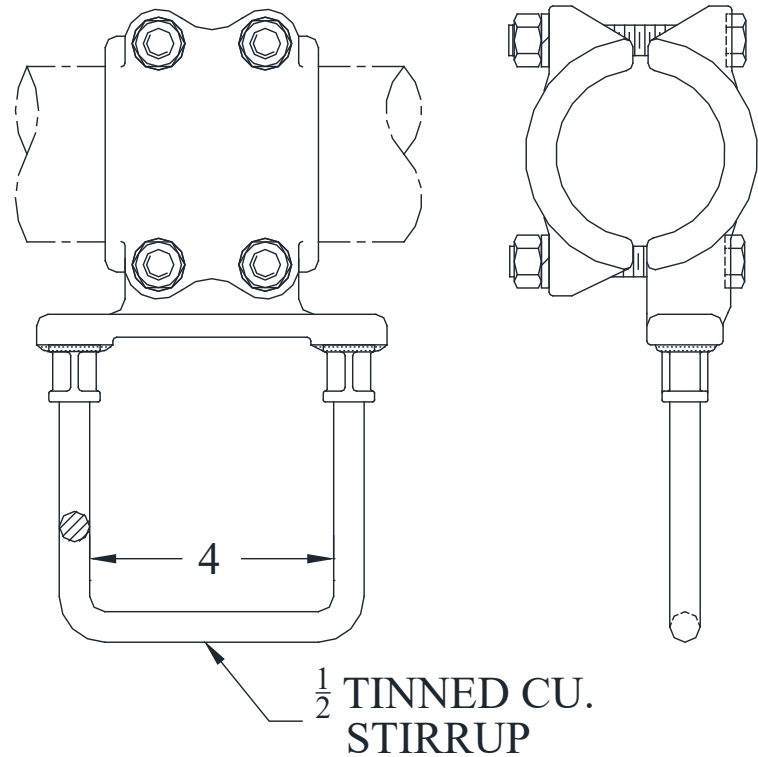

TYPE AHLSC

Line Stirrup
Cable to Stirrup

Aluminum stirrup clamp for ground connections to aluminum cable.
Contact sealant is recommended.
Consult manufacturer for further details or unlisted applications.

Casting Alloy: 356-T6 Aluminum
Clamping Hardware: Aluminum Alloy
Stirrup: Tinned Copper

CATALOG NUMBER	CONDUCTOR RANGE	
	AAC	ACSR
AHLSC-20	4/0 - 500 MCM	3/0 - 397 MCM
AHLSC-24	350 - 650 MCM	336 - 556 MCM
AHLSC-34	550 - 1033 MCM	477 - 954 MCM
AHLSC-39	874 - 1300 MCM	715 - 1113 MCM
AHLSC-46	1250 - 1800 MCM	1113 - 1590 MCM
AHLSC-56	2000 - 3500 MCM	2034 - 3064 MCM

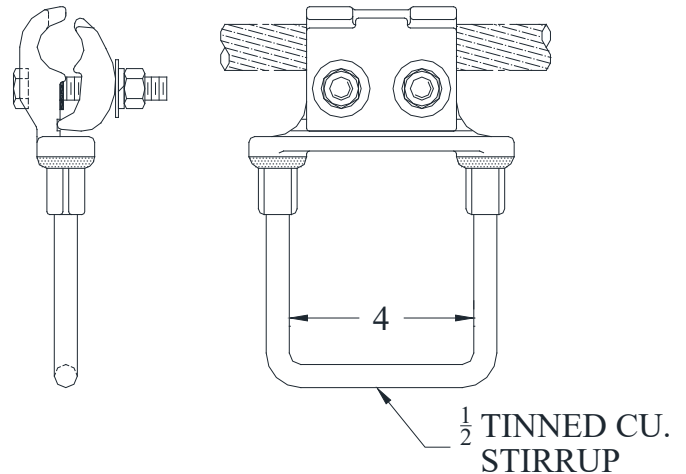

ALUMINUM MISCELLANEOUS

TYPE AHLSW

Welded Hot Line
Pipe to Stirrup

Aluminum welded hot line stirrup

Casting Alloy: 356-T6 Aluminum
Stirrup: Tinned Copper
Ferrule: 1100-0 Aluminum

CATALOG NUMBER	CONDUCTOR SIZE
AHLSW-6064	2" - 6" NPS
AHLSW-6769	5" - 6" NPS
AHLSW-UABC	ALUM ANGLE OR BAR

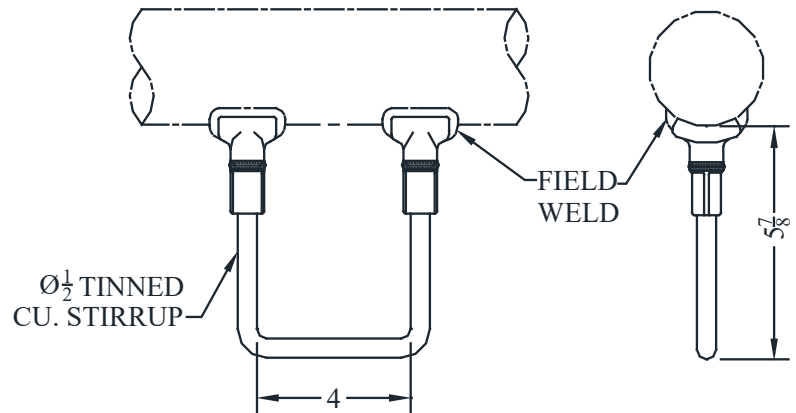

TYPE AHLSW-UABC

Welded Hot Line
Flat Aluminum Bar, UABC, Etc. to Stirrup

Casting Alloy: 356-T6 Aluminum
Stirrup: Tinned Copper
Ferrule: 1100-0 Aluminum

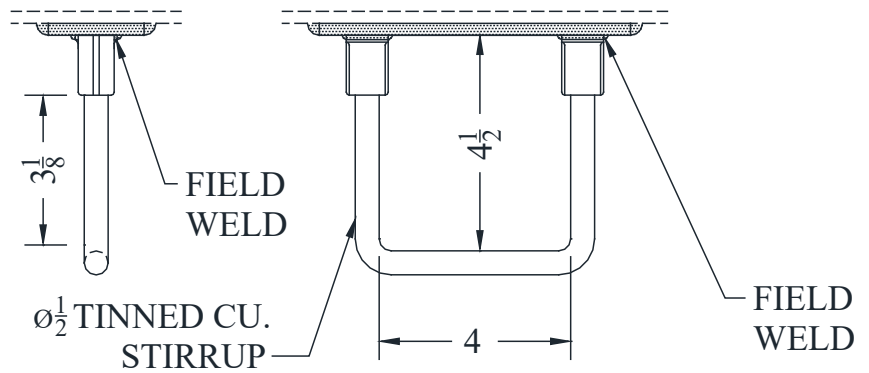

TYPE AHLU-UABC

Bolted Hot Line
Flat Aluminum Bar, UABC, Etc. to Stirrup

Casting Alloy: 356-T6 Aluminum
Stirrup: Tinned Copper
Ferrule: 1100-0 Aluminum
Mounting Hardware: Aluminum Alloy

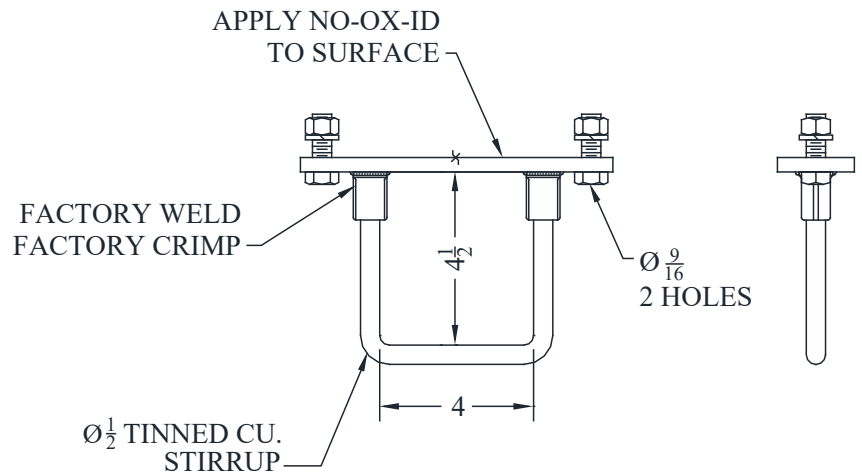

ALUMINUM MISCELLANEOUS

TYPE APGC

Bolted Cross/Parallel
Cable Run to Cable Tap

Casting Alloy: 356-T6 Aluminum
Clamping Hardware: Aluminum Alloy

Aluminum bolted parallel or cross connector for connections on aluminum cable.
Contact sealant is recommended.
Consult manufacturer for further details or unlisted applications.

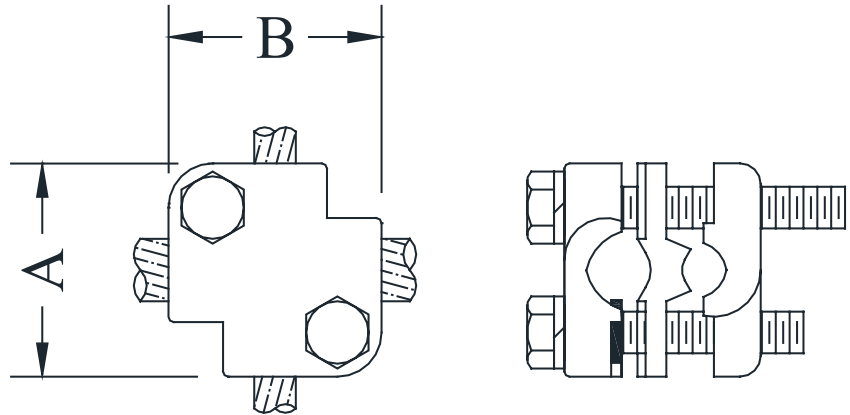

CATALOG NUMBER	CONDUCTOR RANGE		DIMENSIONS - INCHES		WEIGHT (POUNDS)
	MAIN	TAP	A	B	
APGC-1111	#2 - 4/0 AAC	#2 - 4/0 AAC	2-5/8	2-5/8	1.40
APGC-1818	#2 - 397 AAC	#2 - 397 AAC	2-3/4	2-3/4	0.90
APGC-2011	4/0 - 500 AAC	#1 - 250 AAC	2-9/16	2-9/16	0.90
APGC-2916	336 - 795 AAC	1/0 - 336 AAC	2-7/8	2-7/8	1.20
APGC-2929	397 - 795 AAC	397 - 795 AAC	3	3	3.20

TYPE ATP

Bimetallic
Transition Plate

Material: 80% Aluminum
20% Copper

Bimetallic transition plate for making aluminum to copper connections.
Total thickness is 1/16".
Contact sealant is recommended.

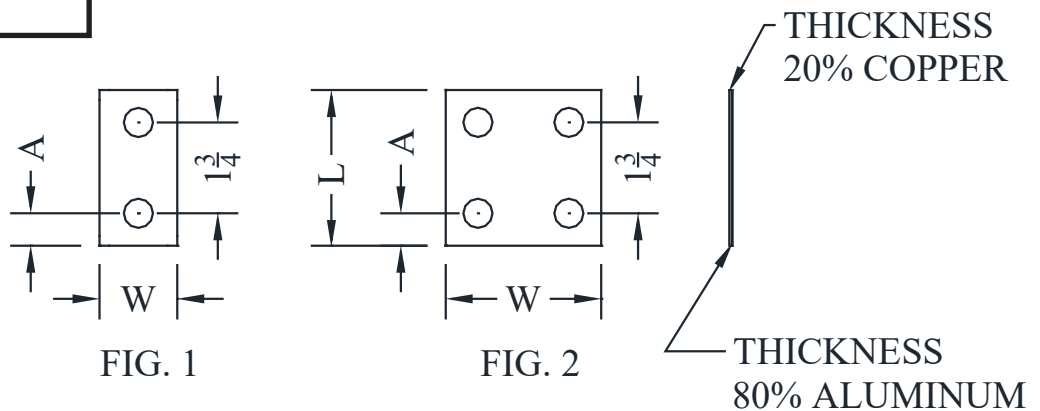

CATALOG NUMBER	FIG. NO.	DIMENSIONS - INCHES			WEIGHT (POUNDS)
		L	A	W	
ATP-B	1	3	5/8	1-1/2	0.05
ATP-B2	1	3	5/8	2	0.05
ATP-C	2	3	5/8	3	0.10
ATP-D	2	4	1-1/8	4	0.15

ALUMINUM MISCELLANEOUS

TYPE ASIW

Horizontal Bolted
IWBC to Insulator

Casting Alloy: 356-T6 Aluminum
Clamping Hardware: Aluminum Alloy

ALUMINUM BUS SUPPORTS for slip or rigid fit for IWCB.
Consult manufacturer for further details or unlisted applications.

FOR RIGID FIT, INVERT CLAMPING
LUGS FROM POSITION SHOWN

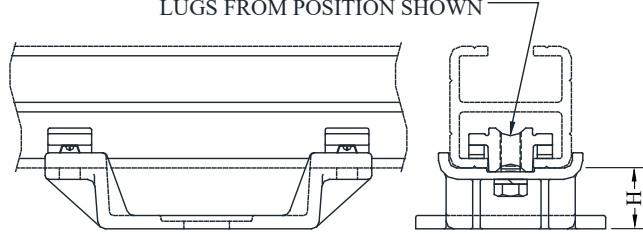

CATALOG NUMBER	CONDUCTOR SIZE IWCB	DIMENSIONS - INCHES	
		BOLT CIRCLE	H
ASIW-63-3	4 X 4 OR 4 X 6	3	2
ASIW-63-5		5	2
ASIW-63-7		7	2

TYPE ASIWP

Horizontal Bolted IWCB
To Insulator

Casting Alloy: 356-T6 Aluminum
Clamping Hardware: Aluminum Alloy
Base: Fabricated 6061-T6

ALUMINUM BUS SUPPORTS for slip or rigid fit for IWCB cast & fabricated.
Consult manufacturer for further details or unlisted applications.

CATALOG NUMBER	FIG. NO.	CONDUCTOR SIZE IWCB	BOLT CIRCLE
ASIWP-63-3	1	4 X 4 Or 4 X 6	3
ASIWP-63-3R	2		3
ASIWP-63-5	1		5
ASIWP-63-5R	2		5
ASIWP-63-7	1		7
ASIWP-63-7R	2		7
ASIWP-68-3	1	6 X 6 Or 5 X 8 Or 8 X 8	3
ASIWP-68-3R	2		3
ASIWP-68-5	1		5
ASIWP-68-5R	2		5
ASIWP-68-7	1		7
ASIWP-68-7R	2		7
ASIWP-715-3	1	9 X 9	3
ASIWP-715-3R	2		3
ASIWP-715-5	1		5
ASIWP-715-5R	2		5
ASIWP-715-7	1		7
ASIWP-715-7R	2		7
ASIWP-717-3	1	10 X 10	3
ASIWP-717-3R	2		3
ASIWP-717-5	1		5
ASIWP-717-5R	2		5
ASIWP-717-7	1		7
ASIWP-717-7R	2		7

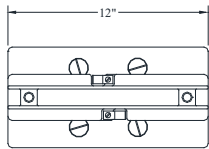

FIGURE 1

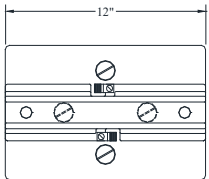
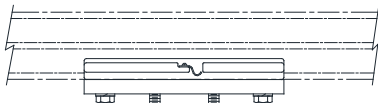
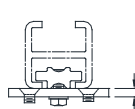
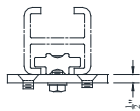
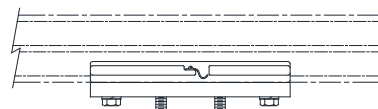

FIGURE 2



ALUMINUM MISCELLANEOUS

TYPE ASUA

Horizontal Bus Support
UABC to Insulator

Aluminum bolted bus support for UABC single run.
It can be used for slip or rigid fit.
The -SE suffix can be removed if used in a rigid fit only application.
Bolts have hex stops for one wrench installation.
Consult manufacturer for further details or unlisted applications.

Casting Alloy: 356-T6 Aluminum
Clamping Hardware: Stainless Steel

CATALOG NUMBER	CONDUCTOR SIZE UABC	BC	A
ASUA-325-3-SE	1/4 x 3-1/4 x 3-1/4	3	13/16
ASUA-325-5-SE	1/4 x 3-1/4 x 3-1/4	5	7/8
ASUA-400-3-SE	1/4 x 4 x 4	3	13/16
ASUA-400-5-SE	1/4 x 4 x 4	5	7/8
ASUA-400H-3-SE	3/8 x 4 x 4	3	13/16
ASUA-400H-5-SE	3/8 x 4 x 4	5	7/8

Slip fit shown.
For rigid fit invert cap.

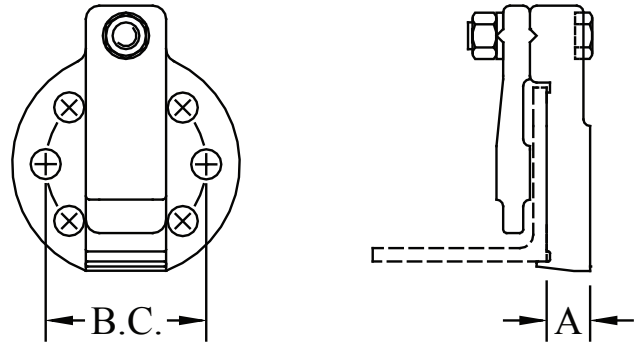

* Tees, couplers, splice assemblies, expansions, terminals and customer specs for aluminum angle are also available upon request.

TYPE ASUA2

Horizontal Bolted (2) UABC
To Insulator

Casting Alloy: 356-T6 Aluminum
Clamping Hardware: Stainless Steel

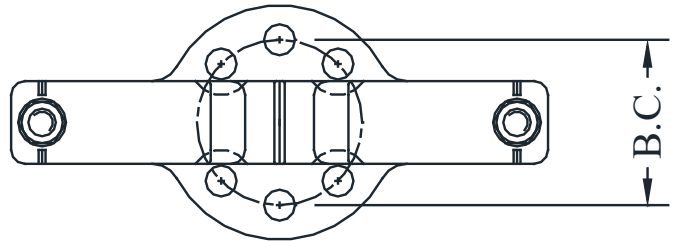

$3\frac{1}{4} \times 3\frac{1}{4} \times \frac{1}{4}$ UABC
WITH $\frac{1}{4}$ SPACING

Slip fit shown.
For clamp fit invert cap.

CATALOG NUMBER	CONDUCTOR SIZE UABC	BOLT CIRCLE
ASUA2-325-3	(2) 3-1/4 x 3-1/4	3
ASUA2-325-5	(2) 3-1/4 x 3-1/4	5

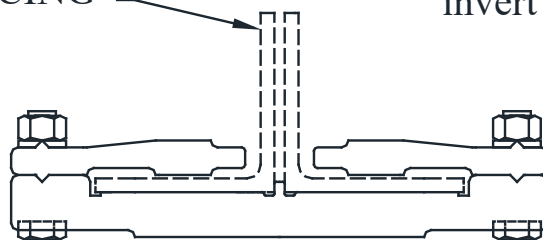

* Tees, couplers, splice assemblies, expansions, terminals and customer specs for aluminum angle are also available upon request.

ALUMINUM MISCELLANEOUS

TYPE ATS

Straight Bolted
Stud to Pipe

Aluminum bolted grounding stud for grounding aluminum pipe.
Consult manufacturer for further details or unlisted applications.

Casting Alloy: 356-T6 Aluminum
Clamping Hardware: Aluminum Alloy

CATALOG NUMBER	PIPE SIZE
ATS-58	2" NPS
ATS-60	2-1/2" NPS
ATS-62	3" NPS
ATS-63	3-1/2" NPS
ATS-64	4" NPS
ATS-67	5" NPS

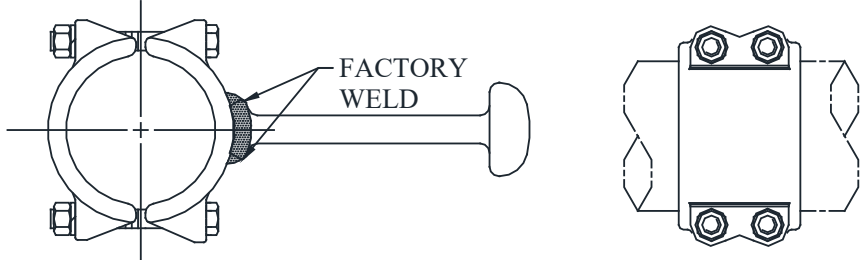

TYPE GSAL2N-4

Straight Bolted
Flat Pad to Stud

Aluminum grounding stud for grounding aluminum flat bar pads.
NEMA drilling is standard.
Contact sealant is recommended.
A bronze version is also available, example: GSAL2N-4-BR.
Consult manufacturer for further details or unlisted applications.

Casting: 356-T6 Aluminum

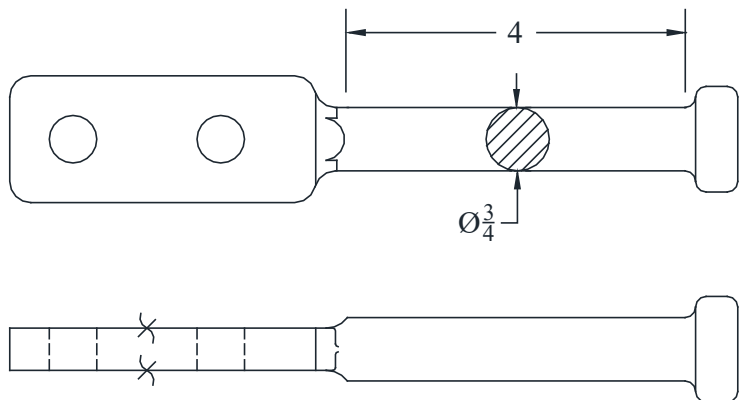

ALUMINUM MISCELLANEOUS

TYPE PUAL

Parallel Connector
Cable to Cable

Aluminum parallel connector for aluminum to aluminum conductor splice/tap connections.
Contact sealant is recommended.
Consult manufacturer for further details or unlisted applications.

Casting Alloy: 356-T6 Aluminum
Clamping Hardware: Stainless Steel

CATALOG NUMBER	RUN		TAP	
	AAC	ACSR	AAC	ACSR
PUAL-5050	2/0 - 4/0	1/0 - 3/0	2/0 - 4/0	1/0 - 3/0
PUAL-5555	1/0 - 400	#1 - 336	1/0 - 400	#1 - 336
PUAL-5951	250 - 650	4/0 - 556	#1 - 266	#2 - 4/0
PUAL-5959	250 - 650	4/0 - 556	250 - 650	4/0 - 556
PUAL-6155	500 - 800	397 - 636	1/0 - 400	#1 - 336
PUAL-6161	500 - 800	397 - 636	500 - 800	397 - 636
PUAL-6655	500 - 1033	397 - 954	1/0 - 400	#1 - 336
PUAL-6666	450 - 1033	397 - 954	450 - 1033	397 - 954

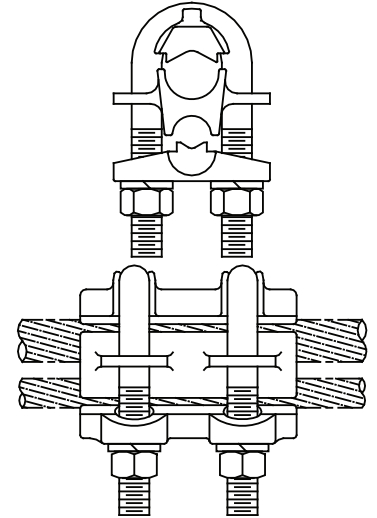

TYPE WTS

Straight Weldment
Stud to Pipe

Aluminum weldment range-taking grounding stud for grounding aluminum pipe.
Consult manufacturer for further details or unlisted applications.

Casting Alloy: 356-T6 Aluminum

CATALOG NUMBER	PIPE SIZE
WTS-3960	1" - 2-1/2" NPS
WTS-6064	2-1/2" - 8" NPS

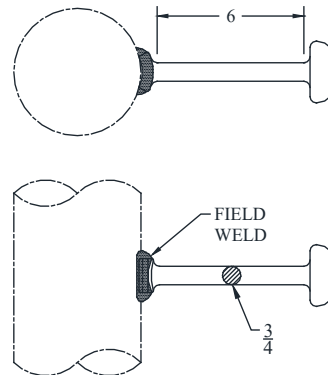

TYPE WTS

Straight Bolted
Flat Pad to Stud

Aluminum alloy for flat bar pads to stud for grounding.
NEMA drilling is standard. Contact sealant is recommended.
Consult manufacturer for further details or unlisted applications.

Casting Alloy: 356-T6 Aluminum

CATALOG NUMBER	PAD SIZE	FIG.
WTS-2B	2" x 3" (2 HOLE)	2
WTS-4A	3" x 3" (4 HOLE)	1
WTS-4B	4" x 4" (4 HOLE)	1

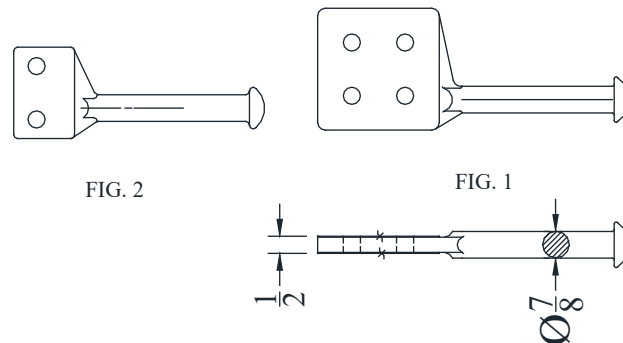

ALUMINUM MISCELLANEOUS

TYPE WVB

Straight Bolted
Pipe Main to Pipe Tap

Casting Alloy: 356-T6 Aluminum
Legs & Braces: 6063-T6 Aluminum

Aluminum welded "A" frame assemblies including vees, tees, legs and braces. The "A" frame is custom made to customer specifications. Consult manufacturer for further details or unlisted applications.

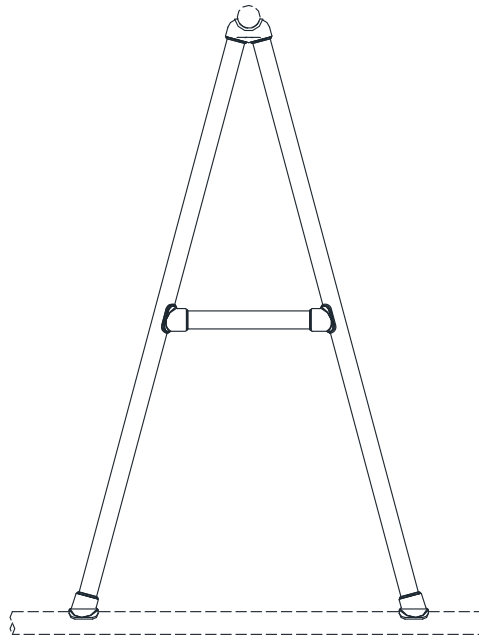

TYPE WRLA

Welded Rope-Lay Assembly
Flat to Flat

Casting Alloy: 356-T6 Aluminum

Aluminum flexible rope-lay assemblies for connecting flat pads. NEMA drilling is standard. Contact sealant is recommended. Assemblies are also available with angled terminals. Consult manufacturer for further details or unlisted applications. Note: Replace (L) in the catalog numbers listed below with the length required.

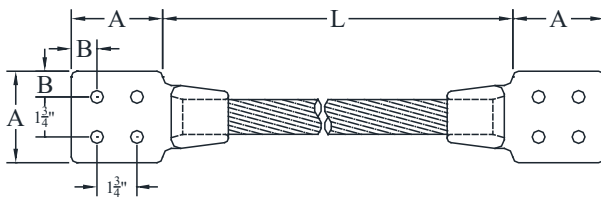

FIG. 1

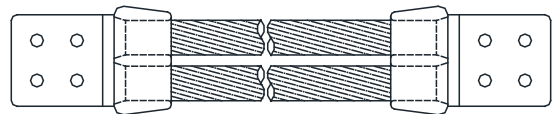

FIG. 2

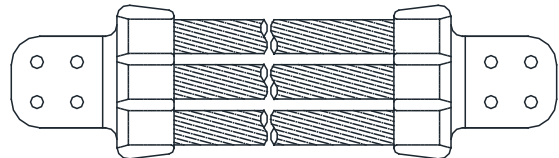

FIG. 3

CATALOG NUMBER	FIG. NO.	DIMENSIONS - INCHES			AMPERE RATING
		A	B	T	
WRLA-1272-4A-(L)	1	3	5/8	5/8	1000
WRLA-1272-4B-(L)	1	4	1 1/8	5/8	1000
WRLA2-1272-4B-(L)	2	4	1 1/8	3/4	2000
WRLA3-1272-4B-(L)	3	4	1 1/8	1	3300

BRONZE MISCELLANEOUS

TYPE BCS/BCSS

Dead End Strain Clamp
Straight / Quadrant

Add suffix - SF or - CF for socket fitting or clevis fitting.
Example: BCS-2034-SF

Casting Alloy: Aluminum Bronze
Clamping Hardware: Silicon Bronze

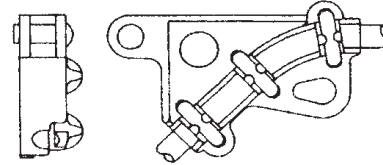

BCS

CATALOG NUMBER	CONDUCTOR SIZE
BCS-20	4 / 0 - 500 MCM QUADRANT
BCS-2034	500 - 1000 MCM QUADRANT
BCS-3442	1000 - 1500 MCM QUADRANT
BCS2-2027	(2) 500 - 750 MCM QUADRANT
BCSS-0814	1/0 STR - 300 MCM STRAIGHT
BCSS-2028	500 - 800 MCM STRAIGHT
BCSS-2734	750 - 1000 MCM STRAIGHT

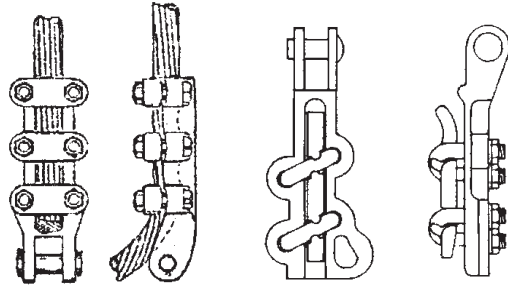

BCSS

TYPE BTS/BCGS

Pipe to Stud
Cable to Stud

Bronze bolted grounding stud for grounding copper pipe or cable.
Consult manufacturer for further details or unlisted applications.

Casting Alloy: Electrical Bronze
Clamping Hardware: Silicon Bronze

CATALOG NUMBER	CONDUCTOR SIZE
BTS-49	1-1/4" NPS
BTS-53	1-1/2" NPS
BCGS-34	4/0 SOL - 1000 MCM

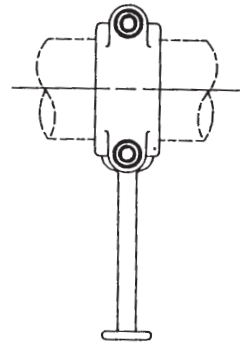

BTS

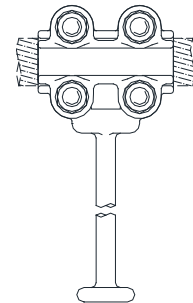

BCGS

TYPE BSA

Bolt Circle/Height
Adapter

Bronze or aluminum bolt circle and/or height adapter.
Consult manufacturer for further details or unlisted applications.

Add suffix: "-BR" for bronze or
"-AL" for aluminum.

Casting: Electrical Bronze or 356-T6 Aluminum

CATALOG NUMBER	BOLT CIRCLE	HEIGHT
BSA-5-3	5" to 3"	1-7/16
BSA-7-5	7" to 5"	1-1/4
BSA3-3-5	5" to 3"	3

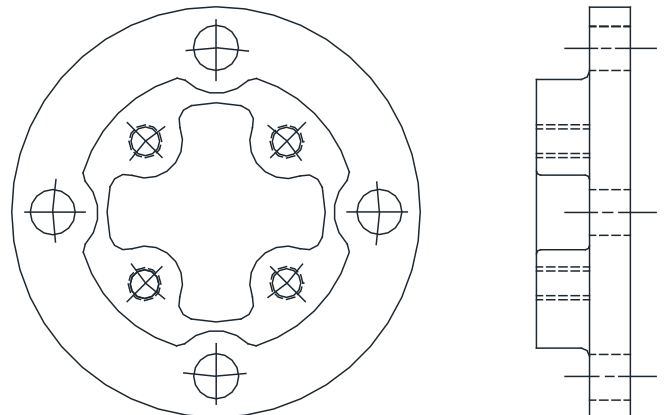

BRONZE MISCELLANEOUS

TYPE CFX

Straight Expansion Bend
Pad to Pad

Laminated Strap: Copper

Copper laminated expansion bend used between bushing terminals and rigid bus. Tinned ends are soldered together under pressure to form one piece unit at contact ends. Pad holes have NEMA spacing. Not recommended as a support member. Pad size & Ampere rating should be specified. Consult manufacturer for further details or unlisted applications.

CATALOG NUMBER	FIG. NO.	A (INCHES)	AMPS (INDOOR)
CFX-2B-2	1	2	900
CFX-4A-1	2	3	700
CFX-4A-2	2	3	1000
CFX-4A-3	2	3	1200
CFX-4B-2	2	4	1200
CFX-4B-3	2	4	1600
CFX-4B-4	2	4	2000
CFX-4B-6	2	4	3000

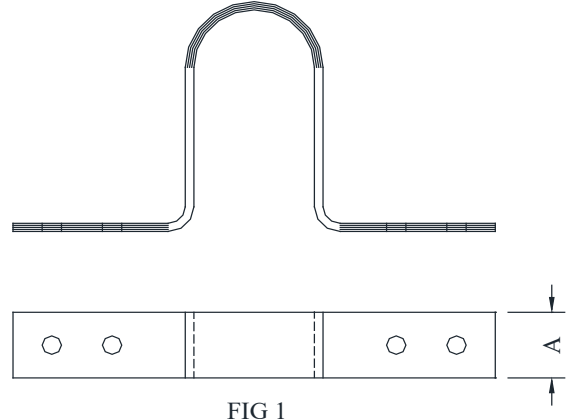

FIG 1

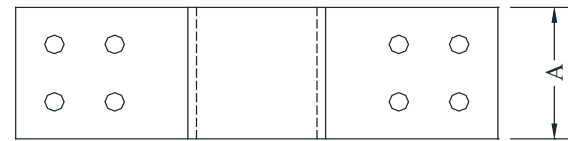

FIG 2

TYPE CFX90

90° Expansion Bend
Pad to Pad

Laminated Strap: Copper

Copper laminated expansion bend used between bushing terminals and rigid bus. Tinned ends are soldered together under pressure to form one piece unit at contact ends. Pad holes have NEMA spacing. Not recommended as a support member. Pad size & Ampere rating should be specified. Consult manufacturer for further details or unlisted applications.

CATALOG NUMBER	FIG. NO.	A (INCHES)	AMPS (INDOOR)
CFX90-2B-2	1	2	800
CFX90-4A-1	2	3	700
CFX90-4A-2	2	3	1000
CFX90-4A-3	2	3	1200
CFX90-4B-2	2	4	1200
CFX90-4B-3	2	4	1600
CFX90-4B-4	2	4	2000
CFX90-4B-6	2	4	3000

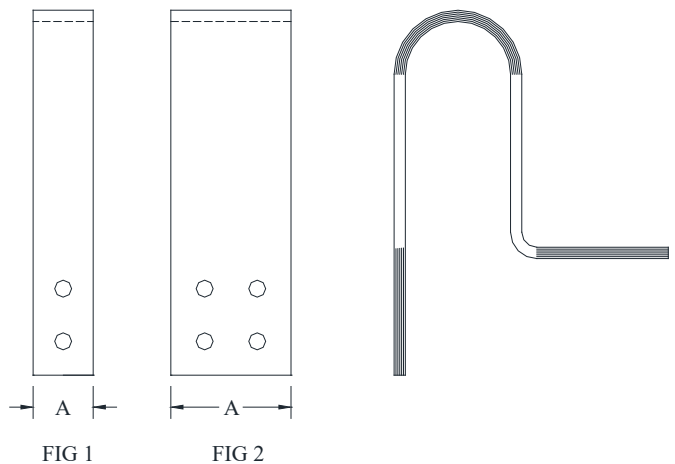

FIG 1



FIG 2

BRONZE MISCELLANEOUS

TYPE GFCS

Parallel Connector
Cable to Cable

Bronze parallel connector with separator for copper to copper connections. Consult manufacturer for further details or unlisted applications.

Casting Alloy: Electrical Bronze
Retaining Ring: Neoprene Rubber
Clamping Hardware: Silicon Bronze

CATALOG NUMBER	CONDUCTOR RANGE	
	RUN	TAP
GFCS-4848	#6 SOL - 2/0 STR	#3 STR - 2/0 STR
GFCS-5050	#1 - 4/0 STR	#6 - 4/0 STR
GFCS-5353	2/0 - 350 MCM	#4 - 350 MCM
GFCS-5656	3/0 - 500 MCM	#4 - 500 MCM
GFCS-6262	350 - 800 MCM	#2 - 800 MCM
GFCS-6666	450 - 1000 MCM	1/0 - 1000 MCM

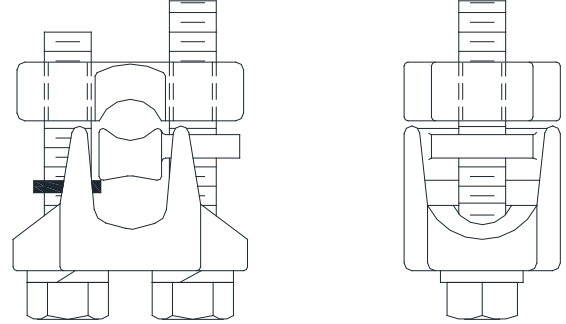

TYPE GCK

Parallel Connector
Cable to Cable

Bronze single U-bolt type parallel connector with separator for copper cable to cable connections. Consult manufacturer for further details or unlisted applications.

Casting Alloy: Electrical Bronze
Clamping Hardware: Silicon Bronze

CATALOG NUMBER	CONDUCTOR RANGE	
	RUN	TAP
GCK-4848	#2 SOL - 2/0 STR	#2 SOL - 2/0 STR
GCK-5050	#1 - 4/0 STR	#1 - 4/0 STR
GCK-5252	1/0 - 300 MCM	1/0 - 300 MCM
GCK-5656	4/0 - 500 MCM	4/0 - 500 MCM

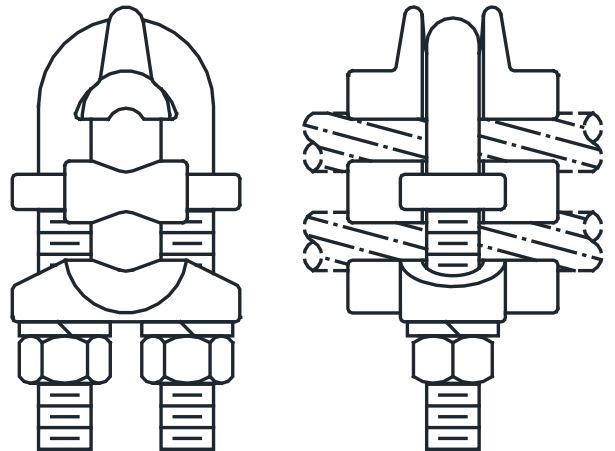

TYPE GLT-12

Bronze Grounding Terminal
Cable to Terminal

A through-type grounding terminal for apparatus grounding pads having tapped holes on a NEMA 2-hole pattern. Connector allows continuity of the ground conductor where required. Conductor sizes: #6 STR through 250 MCM.

Casting Alloy: Electrical Bronze
Clamping Hardware: Silicon Bronze
Mounting Hardware: Silicon Bronze

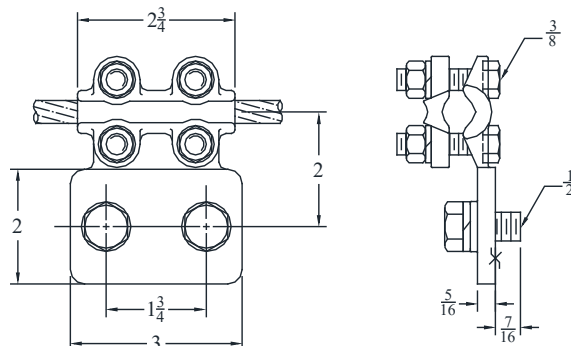

BRONZE MISCELLANEOUS

TYPE SXR/SXR2

Straight or 90° Bolted
Terminal to Cable or Pipe

Bronze bolted terminal that can be used for straight or 90° connections to cable or pipe to flat bar or terminal pad.
Consult manufacturer for further details or unlisted applications.

Casting Alloy: Electrical Bronze
Clamping Hardware: Silicon Bronze

CATALOG NUMBER	CONDUCTOR RANGE	
	CABLE	NPS
NEMA DRILLING		
SXR-34	#2 - 1000 MCM	3/8"-3/4"
SXR2-34	(2) #2 - 1000 MCM	3/8"-3/4"
NON-NEMA DRILLING		
SXR-48	#2 - 2000 MCM	3/8"-1"
SXR2-48	(2) #2 - 2000 MCM	3/8"-1"

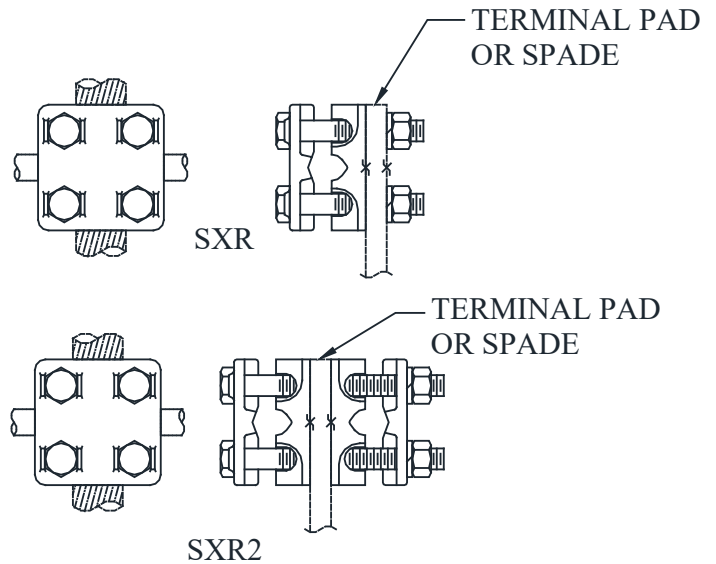

TYPE FNXR

Dual Function/Tee Connector/Terminal
Terminal to Cable or Pipe

Bronze bolted, dual function tee/terminal for cable or pipe connections to flat pad tap. Reversible cap allows a wide range conductor, straight or 90° to a 2 or 4 hole NEMA flat.

Casting Alloy: Electrical Bronze
Clamping Hardware: Silicon Bronze

CATALOG NUMBER	FIG. NO.	WIDTH IN. (W)	T	CONDUCTOR RANGE	
				CABLE	NPS
FNXR-0139-2B	2	2	1/2	#8 - 1300 MCM	1/4" - 1"
FNXR-0139-4A	1	3	3/8	#8 - 1300 MCM	1/4" - 1"
FNXR-0420-2B	2	2	3/8	#4 - 500 MCM	1/4" - 3/8"
FNXR-39-2B	2	2	1/2	350 - 1500 MCM	1/2" - 1"
FNXR-39-4A	1	3	1/2	350 - 1500 MCM	1/2" - 1"
FNXR-48-4A	1	3	3/4	#2 - 2000 MCM	3/8" - 1"
FNXR-48-4B	1	4	3/4	#2 - 2000 MCM	3/8" - 1"

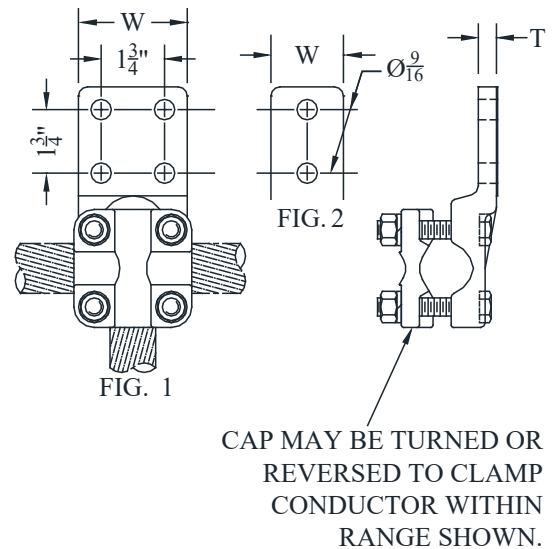

BRONZE MISCELLANEOUS

TYPE HLS

Stirrup Clamp
Pipe Main to Stirrup

Bronze stirrup clamp for ground connections to copper pipe.
Contact sealant is recommended.
Consult manufacturer for further details or unlisted applications.

Casting Alloy: Electrical Bronze
Stirrup: Tinned Copper
Clamping Hardware: Silicon Bronze

CATALOG NUMBER	PIPE SIZE (NPS)
HLS-30	3/4
HLS-39	1
HLS-49	1-1/4
HLS-53	1-1/2
HLS-58	2
HLS-60	2-1/2
HLS-62	3
HLS-63	3-1/2
HLS-64	4

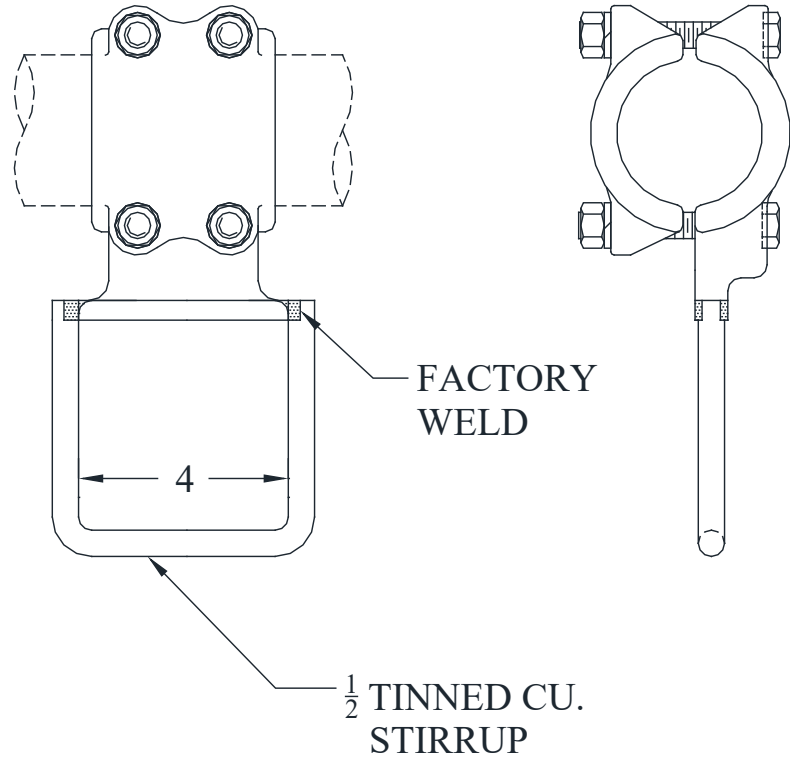

TYPE HLSC

Stirrup Clamp
Cable Main to Stirrup

Bronze stirrup for ground connections to copper cable.
Contact sealant is recommended.
Consult manufacturer for further details or unlisted applications.

Casting Alloy: Electrical Bronze
Stirrup: Tinned Copper
Clamping Hardware: Silicon Bronze

CATALOG NUMBER	CONDUCTOR RANGE
HLSC-0711	#1 SOL - 4/0 MCM
HLSC-1020	3/0 - 500 MCM
HLSC-1420	300 - 500 MCM
HLSC-2028	500 - 800 MCM
HLSC-2034	500 - 1000 MCM
HLSC-2734	750 - 1000 MCM
HLSC-3842	1200 - 1500 MCM
HLSC-4248	1500 - 2000 MCM
HLSC-48	2000 MCM

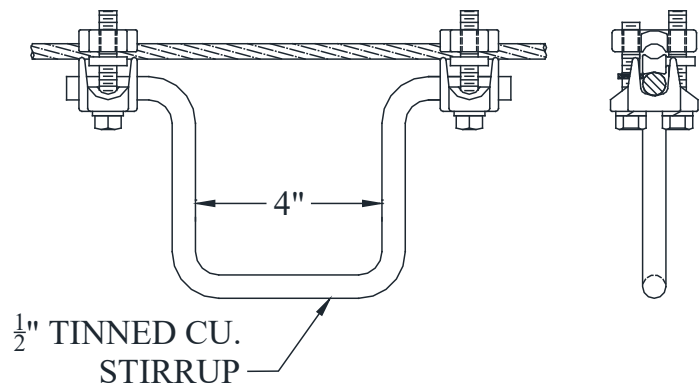

BRONZE MISCELLANEOUS

TYPE OGP

Cross or Parallel Bolted
Cable to Cable

Bronze connector used with copper cable in a cross or parallel bolted configuration.

Casting Alloy: Electrical Bronze
Clamping Hardware: Silicon Bronze

CATALOG NUMBER	CONDUCTOR RANGE	
	RUN	TAP
OGP-5050	#2 SOL - 4/0 STR	#2 SOL - 4/0 STR
OGP-5650	250 - 500 MCM	#1 SOL - 4/0 STR
OGP-6666	500 - 1000 MCM	500 - 1000 MCM

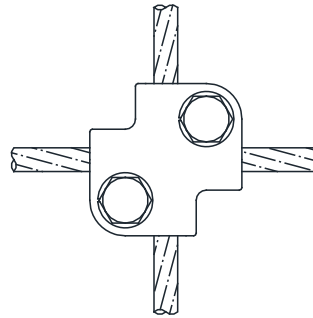

Cross Bolted

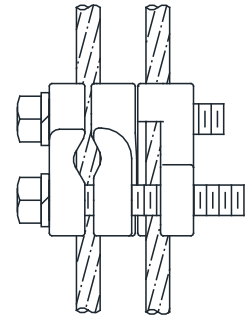

Parallel Bolted

TYPE OGC

Cross Bolted
Cable to Cable

Bronze connector used with copper cable in a cross bolted configuration.

Casting Alloy: Electrical Bronze
Clamping Hardware: Silicon Bronze

CATALOG NUMBER	CONDUCTOR RANGE	
	RUN	TAP
OGC-4848	#4 SOL - 2/0 STR	#4 SOL - 2/0 STR
OGC-5151	2/0 - 250 MCM	2/0 - 250 MCM
OGC-5656	300 - 500 MCM	300 - 500 MCM
OGC-6161	550 - 750 MCM	550 - 750 MCM

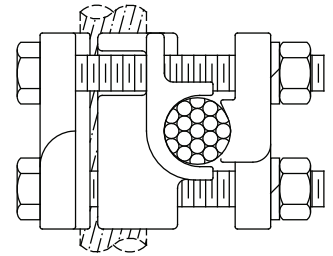
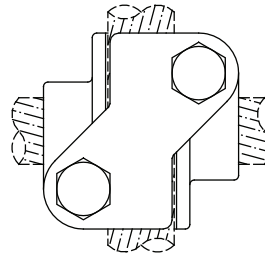

TYPE PU

Parallel Bolted Clamp
Cable to Cable

Bronze double U-bolt type parallel connector with spacer or separator for cable to cable connections.
Consult manufacturer for further details or unlisted applications.

Casting Alloy: Electrical Bronze
Clamping Hardware: Silicon Bronze

CATALOG NUMBER	CONDUCTOR RANGE	
	RUN	TAP
PU-5050	#2 - 4/0 STR	#2 - 4/0 STR
PU-5252	1/0 - 300 MCM	1/0 - 300 MCM
PU-5656	300 - 500 MCM	300 - 500 MCM
PU-6250	500 - 800 MCM	1/0 - 4/0 STR
PU-6262	500 - 800 MCM	500 - 800 MCM
PU-7262	1000 - 1500 MCM	500 - 800 MCM
PU-7878	1500 - 2000 MCM	1500 - 2000 MCM

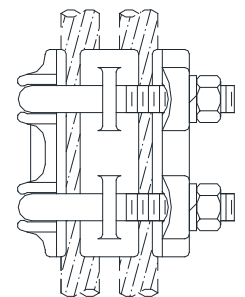
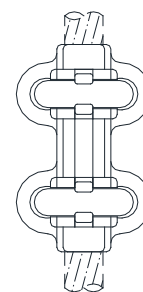

BRONZE MISCELLANEOUS

TYPE PAU

Parallel Connector
Cable to Cable

Multi-bolted, range taking bronze parallel connector with multiple center bolts for use with copper to copper cable connections. Consult manufacturer for further details or unlisted applications.

Casting Alloy: Electrical Bronze
Clamping Hardware: Silicon Bronze

CATALOG NUMBER	CONDUCTOR RANGE	
	RUN	TAP
*PAU-47	#6 - 1/0 STR	#6 - 1/0 STR
*PAU-50	#4 SOL - 4/0 STR	#4 SOL - 4/0 STR
*PAU-52	#2 SOL - 300 MCM	#2 SOL - 300 MCM
PAU-56	4/0 - 500 MCM	4/0 - 500 MCM
PAU-62	4/0 - 800 MCM	4/0 - 800 MCM
PAU-66	500 - 1000 MCM	500 - 1000 MCM

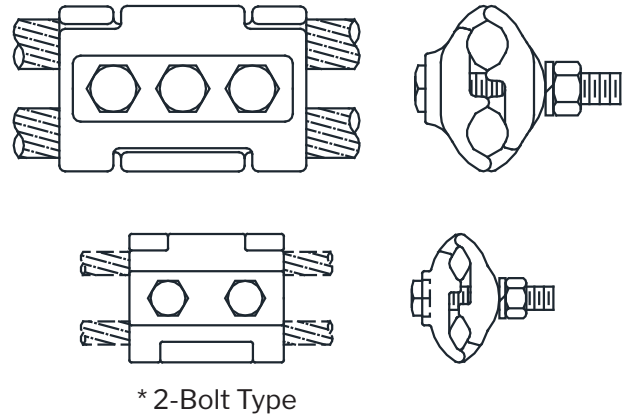

TYPE PA

Parallel Connector
Cable to Cable

Bronze multi-bolted parallel clamp used in parallel cable to cable connections. Consult manufacturer for further details or unlisted applications.

Casting Alloy: Electrical Bronze
Clamping Hardware: Silicon Bronze

CATALOG NUMBER	CONDUCTOR RANGE	
	RUN	TAP
*PA-4747	1/0 STR	1/0 STR
PA-4949	3/0 STR	3/0 STR
*PA-5045	4/0 STR	#2 STR
*PA-5047	4/0 STR	1/0 STR
PA-5050	4/0 STR	4/0 STR
*PA-5147	250 MCM	1/0 STR
PA-5650	500 MCM	4/0 STR
PA-5653	500 MCM	350 MCM
PA-5656	500 MCM	500 MCM

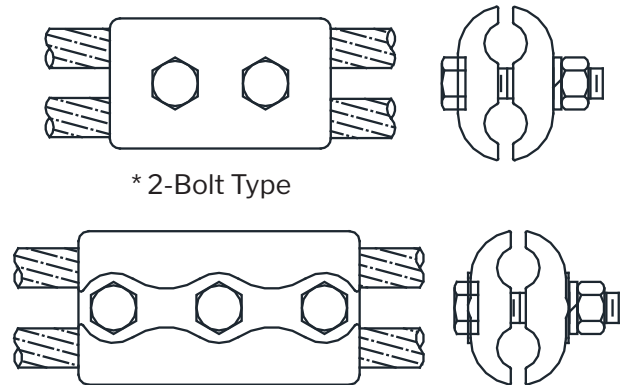

TYPE PL

Parallel Connector
Connector to Cable

Single bolt two piece bronze connector for connecting copper cable, copper weld, guy strand or static wire.

Casting Alloy: Electrical Bronze
Clamping Hardware: Silicon Bronze

CATALOG NUMBER	CABLE RANGE (A)		DIMENSIONS - INCHES	
	MIN.	MAX	B	N
PL-50	#6 STR	4/0 STR	2	1/2

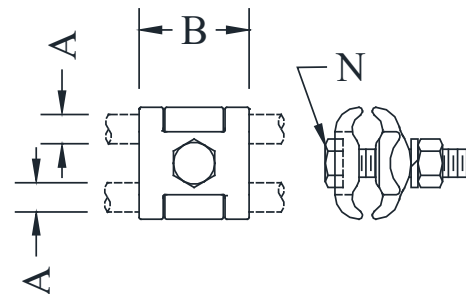

BRONZE MISCELLANEOUS

TYPE PDC

Parallel Connector
Cable to Cable

Single bolt parallel connector for copper to copper cable connections. Consult manufacturer for further details or unlisted applications.

Casting Alloy: Electrical Bronze
Clamping Hardware: Silicon Bronze

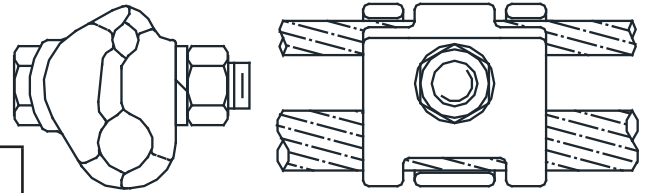

CATALOG NUMBER	CONDUCTOR RANGE	
	RUN	TAP
PDC-1107	1/0 SOL - 4/0 STR	#8 SOL - 1 STR
PDC-4747	#6 - 1/0 STR	#6 - 1/0 STR
PDC-5046	#2 - 4/0 STR	#8 SOL - 1 STR
PDC-5247	1/0 - 300 MCM	#6 - 1/0 STR

TYPE PGC2

Straight Bolted
Cable to Cable

Bronze bolted connector used with copper cable in a cross or parallel configuration. Consult manufacturer for further details or unlisted applications.

Consult manufacturer for further details or unlisted applications.

Casting Alloy: Electrical Bronze
Clamping Hardware: Silicon Bronze

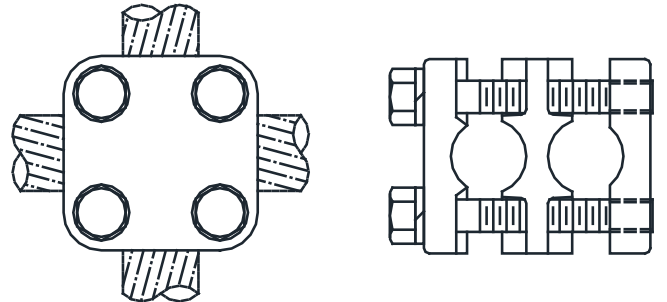

CATALOG NUMBER	CONDUCTOR RANGE	
	RUN	TAP
PGC2-2020	4/0 - 500 MCM	4/0 - 500 MCM
PGC2-3434	500 - 1000 MCM	500 - 1000 MCM

TYPE PT

Parallel Bolted
Cable to Cable

Single bolt bronze parallel connector for copper to copper cable connections. Consult manufacturer for further details or unlisted applications.

Casting Alloy: Electrical Bronze
Clamping Hardware: Silicon Bronze

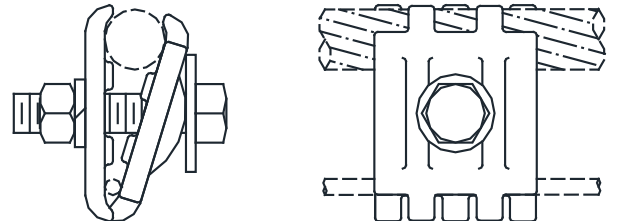

CATALOG NUMBER	CONDUCTOR RANGE	
	MAIN	TAP
PT-4051-A	#8 SOL - 250 MCM	#8 SOL - 250 MCM

BRONZE MISCELLANEOUS

TYPE TASP

Terminal Adapter
Terminal to Flat Pad

Terminal adapter for transformer to flat pad.
Consult manufacturer for further details or unlisted applications.

Casting Alloy: Electrical Bronze

CATALOG NUMBER	STUD DIA.	PAD SIZE
TASP-10-4A	1/2	3" x 3"
TASP-33-4A	1-1/8	3" x 3"

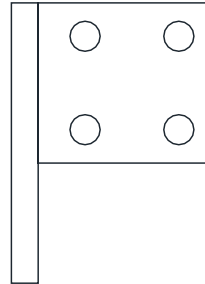

BOTH SIDES
FINISHED

TYPE TXR

Straight Bolted Multi-Purpose
Pipe or Cable

Bronze multi-purpose tee / coupler / parallel connector for copper cable or pipe.
Reversible cap accommodates a wide range of cable or pipe sizes.
Clamping bolts have hex-stops for one-wrench installation.

Casting Alloy: Electrical Bronze
Clamping Hardware: Silicon Bronze

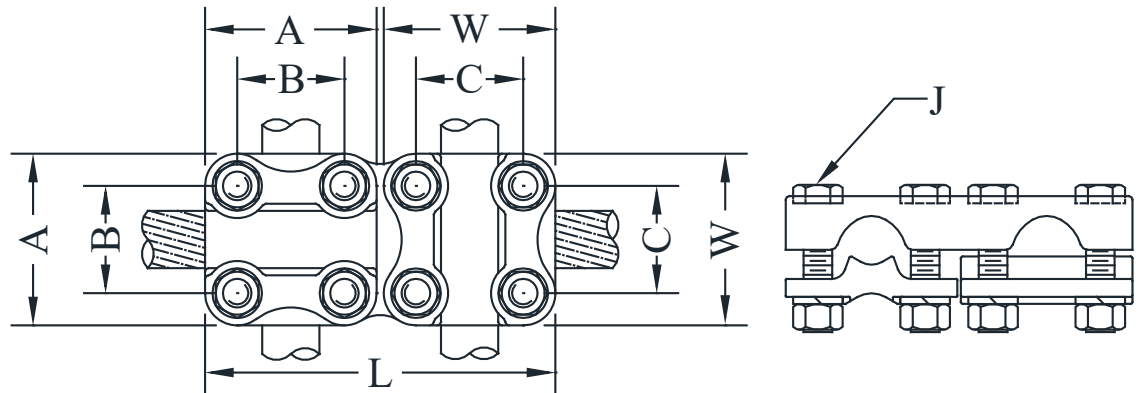

CATALOG NUMBER	CONDUCTOR RANGE				DIMENSIONS - INCHES						WEIGHT (POUNDS)
	MAIN		TAP		L	A	B	C	W	J	
	NPS	CABLE	NPS	CABLE							
TXR-0628	1/4 - 3/4	#2 SOL - 800 MCM	1/4-3/4	#2 SOL - 800 MCM	4-13/16	2-3/8	1-1/2	1-1/2	2-3/8	3/8	3.60
TXR-1134	1/4 - 3/4	4/0 - 1000 MCM	1/4-3/4	4/0 - 1000 MCM	6-1/8	3	1-7/8	1-7/8	3	1/2	5.15
TXR-4830	1/2 - 1-1/4	500 - 2000 MCM	1/4-3/4	#6 - 850 MCM	6-3/4	3-1/2	2-3/8	1-7/8	3	1/2	9.65

BRONZE MISCELLANEOUS

TYPE UMX

Bronze Eye-Bolt
Cable to Terminal

Casting Alloy: Electrical Bronze
Eye-Bolt: Aluminum Bronze/Tinned
Clamping Hardware: Silicon Bronze

Bronze single eye-bolt terminal for connecting copper cable to copper flat.
Cable entrance straight on or 90° to flat.
Consult manufacturer for further details or unlisted applications.

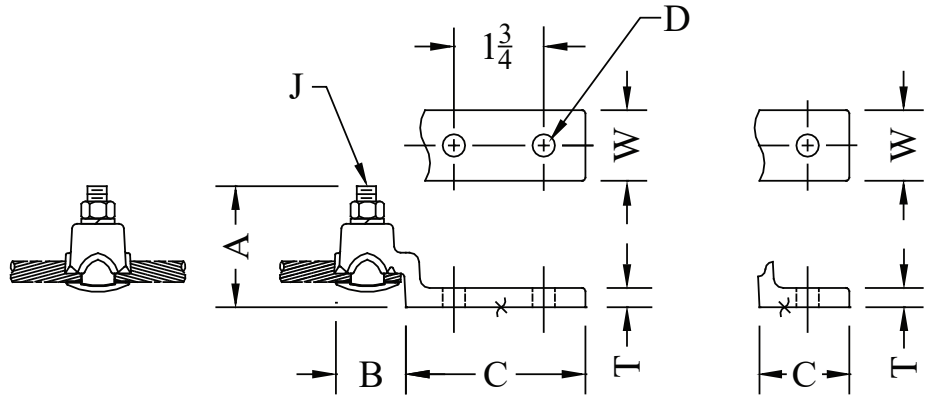

CATALOG NUMBER	CONDUCTOR RANGE	HOLES IN PAD	DIMENSIONS - INCHES						
			A	B	C	D	J	W	T
UMX-4048-1	#8 SOL - 2/0 STR	1	2-5/8	1-3/8	1-3/8	7/16	3/8	3/4	5/16
UMX-4151-1	#6 - 250 MCM	1	3-1/4	2-15/16	1-1/4	9/16	1/2	1-3/8	5/16
UMX-4151-2N	#6 - 250 MCM	2	3-1/4	2-15/16	3	9/16	1/2	1-3/8	5/16
UMX-4756-1	1/0 STR - 500 MCM	1	3-7/8	3-1/8	1-5/8	9/16	1/2	1-3/8	3/8
UMX-4756-2N	1/0 STR - 500 MCM	2	3-7/8	3-5/16	3	9/16	1/2	2	3/8

TYPE XB2N/XB4N

Flexible Braid Shunt

Flexible braid tinned copper shunts.
Available with 2 or 4 hole NEMA drilled pads.
Consult manufacturer for further details or unlisted applications.

Material: Tinned Copper

(L) = desired overall length in inches.
Example: XB2N-145-18

CATALOG NUMBER	FIG. NO.	AMPERE RATINGS	
		INDOOR	OUTDOOR
XB2N-76-(L)	1	225 A.	300 A.
XB2N-145-(L)	1	380 A.	475 A.
XB2N-152-(L)	1	375 A.	485 A.
XB2N-291-(L)	1	500 A.	640 A.
XB2N-437-(L)	1	600 A.	760 A.
XB2N-583-(L)	1	680 A.	810 A.
XB2N-876-(L)	1	1000 A.	1200 A.
XB4N-291-(L)	2	600 A.	780 A.
XB4N-583-(L)	2	800 A.	1000 A.
XB4N-875-(L)	2	1000 A.	1260 A.
XB4N-1168-(L)	2	1200 A.	1500 A.

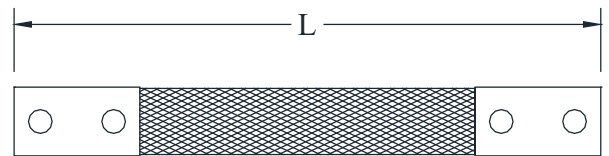

XB2N

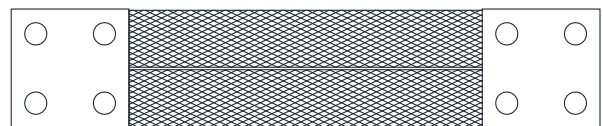

XB4N

EHV MISCELLANEOUS

TYPE WGSTH/WGSTE

Welded Ground Stud to Pipe

Types WGSTH and WGSTE ground studs are designed for corona-free service at 345kV and 500kV respectively. The contact stud is solid aluminum rod, welded into saddle and bell or sphere castings. Because of the damping effect created by the extended sphere, it is recommended that 500kV grounding studs be installed as near to a bus support as practical.

Casting Alloy: 356-T6 Aluminum
Stud: 6061-T6 Aluminum

ALUMINUM • 345 - 500kV

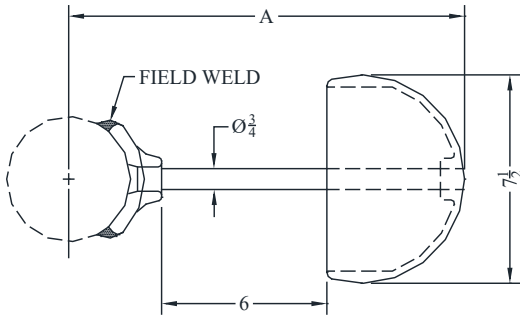

FIG. 1

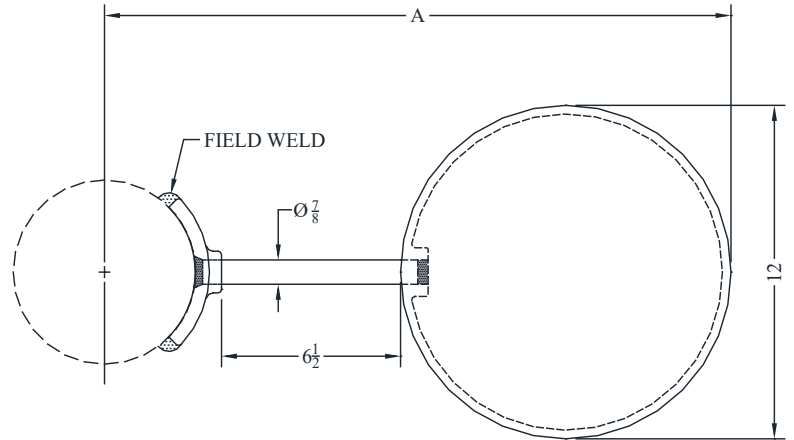

FIG. 2

CATALOG NUMBER	FIG. NO.	MAX KV	PIPE SIZE (NPS)	A
WGSTH-60	1	345	2-1/2	13-5/8
WGSTH-62	1	345	3	13-7/8
WGSTH-63	1	345	3-1/2	14-1/8
WGSTH-64	1	345	4	14-3/8
WGSTH-67	1	345	5	14-7/8
WGSTH-69	1	345	6	15-3/8
WGSTE-62	2	500	3	20-3/4
WGSTE-63	2	500	3-1/2	21
WGSTE-64	2	500	4	21-1/4
WGSTE-67	2	500	5	21-5/8
WGSTE-69	2	500	6	22-3/4

TYPE ABGSH

Bolted Ground Stud For Pipe

Type ABGSH ground stud is designed for corona-free service at 345kV. For catalog number, substitute ABGSH for WGTSH in chart above. Consult manufacturer for further details or unlisted applications.

Casting Alloy: 356-T6 Aluminum
Stud: 6061-T6 Aluminum

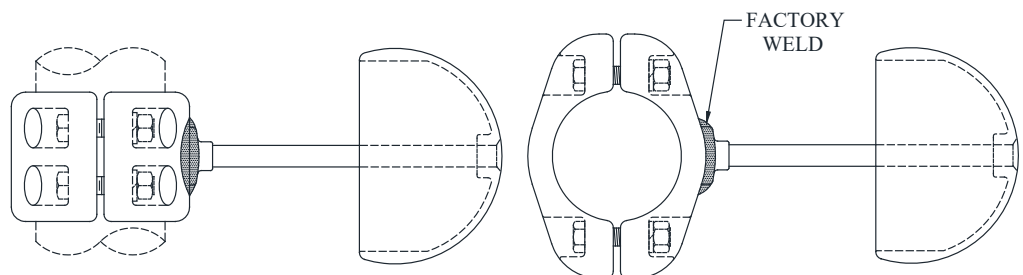

EHV HARDWARE SHIELDS



AA-1094

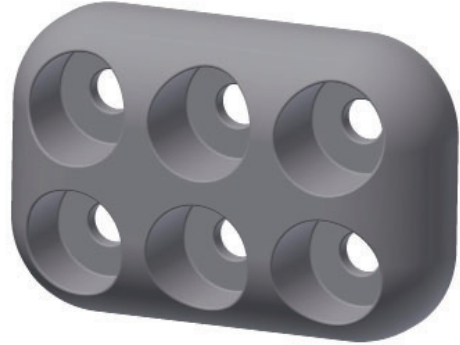

HS-6B

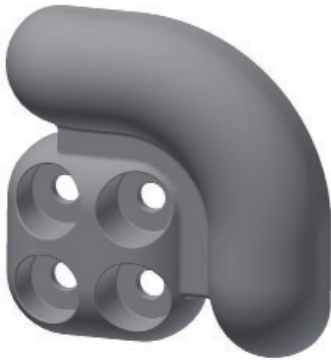

AA-1207

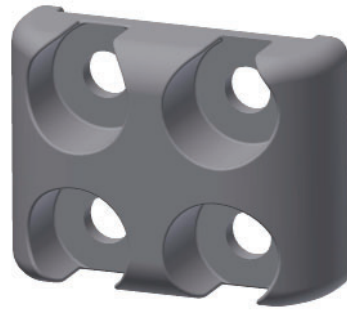

AA-1520

EHV HARDWARE SHIELDS

TYPE AA-1094

Hardware
Shield

Casting Alloy: 356-F Aluminum

ALUMINUM • 345 - 500kV

This 4" x 4" hardware shield is designed to shield pad mounting hardware on in-line 345 and 500kV connections. The pad has NEMA drilling.

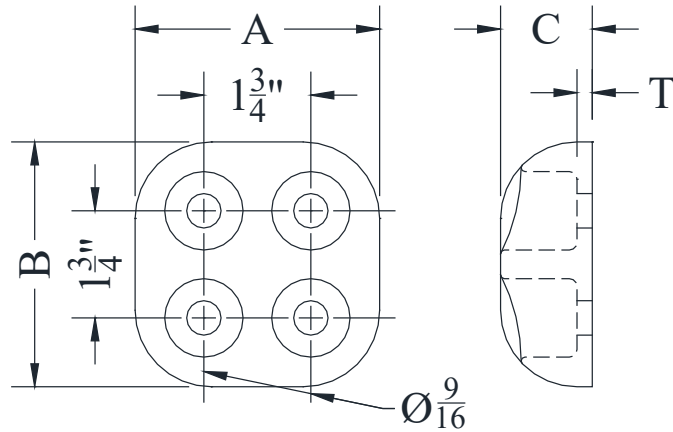

ACCOMMODATES Ø1 1/4" WASHER

CATALOG NUMBER	DIMENSIONS - INCHES				WEIGHT (POUNDS)
	A	B	C	T	
AA-1094	4	4	1-1/2	1/4	1.13

TYPE HS-6B

Hardware
Shield

Casting Alloy: 356-F Aluminum

ALUMINUM • 345 - 500kV

This 6" x 4" hardware shield is designed to shield pad mounting hardware on in-line 345 and 500kV connections. The pad has NEMA drilling.

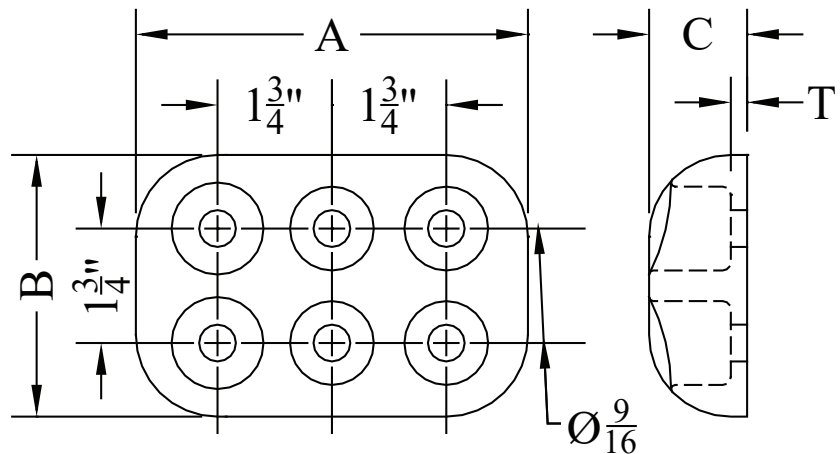

ACCOMMODATES Ø1 1/4" WASHER

CATALOG NUMBER	DIMENSIONS - INCHES				WEIGHT (POUNDS)
	A	B	C	T	
HS-6B	6	4	1-1/2	1/4	2.00

EHV HARDWARE SHIELDS

TYPE AA-1207

90° Hardware
Shield

This 4" x 4' hardware shield is designed for 90° take-off for 345kV and below. It is generally used in pairs. Additional shielding may be required at 500kV. It is not necessary that terminal pad corners be rounded when using this shield.

Casting Alloy: 356-F Aluminum

ALUMINUM • 345 - 500kV

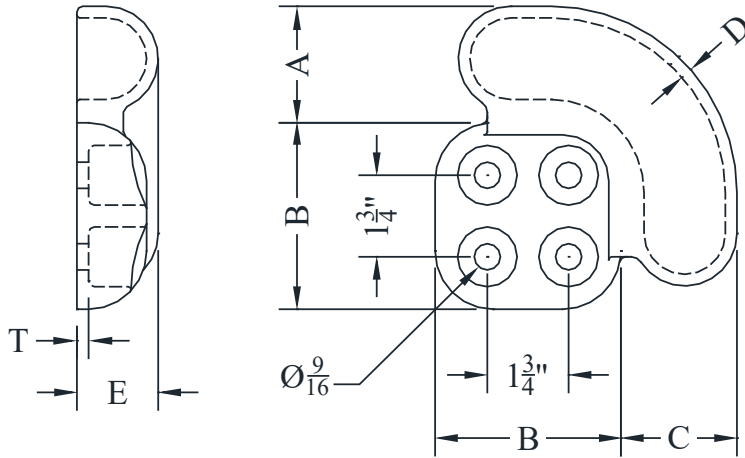

CATALOG NUMBER	DIMENSIONS - INCHES						WEIGHT (POUNDS)
	A	B	C	D	E	T	
AA-1207	2-1/2	4	2-1/2	4	1-3/4	1/4	2.50

TYPE AA-1520

Hardware
Shield

This hardware shield is designed to shield pad mounting hardware on in-line 230kV connections on NEMA 3" x 3" pads.

Casting Alloy: 356-F Aluminum

ALUMINUM • 345 - 500kV

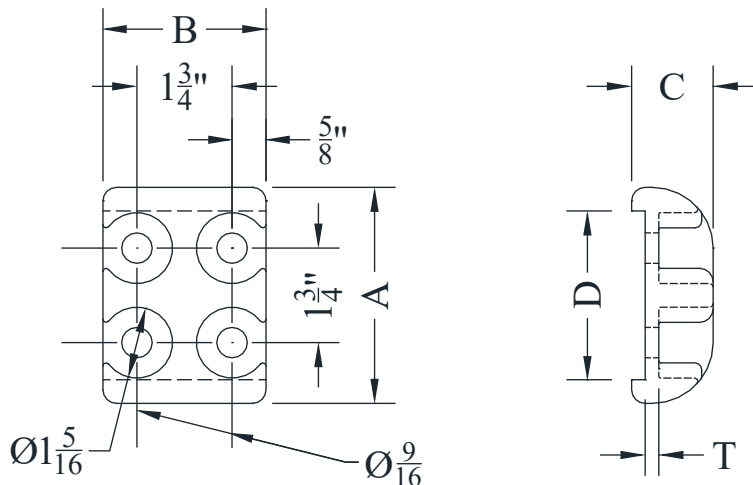

CATALOG NUMBER	DIMENSIONS - INCHES					WEIGHT (POUNDS)
	A	B	C	D	T	
AA-1520	4	3	1-1/2	3-1/8	1/4	1.00

GROUND CONNECTORS



1-OC



2-OC



GUI



GBR



OCS



OF



PL



GF



GF2



GTC

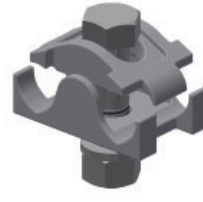

GTC2



GTT2



GLT-12



UN



UNN



GCK



XBG

GROUND CONNECTORS

TYPE 1-OC

Single Cable to Pipe
Parallel or 90°

Casting Alloy: Electrical Bronze
Clamping Hardware: Silicon Bronze

All-bronze ground connector for NPS or O.D. fence posts to copper wire or cable.
NOTE: Separate sizes for some O.D. sizes.

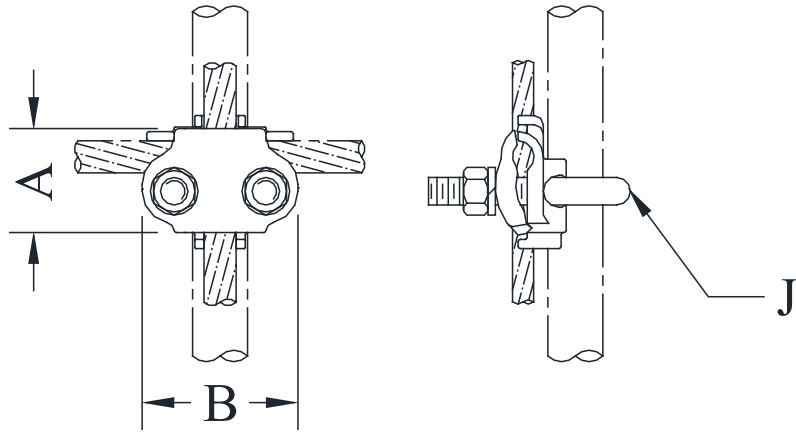

CATALOG NUMBER	PIPE SIZE		CONDUCTOR RANGE		DIMENSIONS - INCHES			WEIGHT (POUNDS)
	(NPS)	(O.D.)	MINIMUM	MAXIMUM	A	B	J	
1-OC-2148	3/8	5/8 - 3/4	#4 SOL	2/0 STR	1-13/16	2-1/8	3/8	0.70
1-OC-2151			2/0 SOL	250 MCM	2-1/16	2-1/4	3/8	1.00
1-OC-2156			300 MCM	500 MCM	2-9/16	2-9/16	1/2	1.25
1-OC-2343	3/4	1	#8 SOL	#4 STR	2	2-5/16	3/8	0.85
1-OC-2348			#4 SOL	2/0 STR	1-13/16	2-5/16	3/8	1.00
1-OC-2351			2/0 SOL	250 MCM	2-1/16	2-5/16	3/8	1.00
1-OC-2356			300 MCM	500 MCM	2-9/16	2-3/4	1/2	1.30
1-OC-2443	1	1-1/4	#8 SOL	#4 STR	2-1/16	2-9/16	3/8	0.80
1-OC-2448			#4 SOL	2/0 STR	1-13/16	2-9/16	3/8	0.90
1-OC-2451			2/0 SOL	250 MCM	2-1/16	2-9/16	3/8	1.00
1-OC-2456			300 MCM	500 MCM	2-9/16	3	1/2	0.85
1-OC-2543	1-1/4	1-3/4	#8 SOL	#4 STR	2-1/16	3	3/8	1.05
1-OC-2548			#4 SOL	2/0 STR	1-13/16	2-15/16	3/8	1.00
1-OC-2551			2/0 SOL	250 MCM	2-1/16	2-15/16	3/8	0.80
1-OC-2556			300 MCM	500 MCM	2-9/16	3	1/2	0.85
1-OC-2648	1-1/2	1-7/8	#4 SOL	2/0 STR	1-13/16	3-3/16	3/8	1.05
1-OC-2651			2/0 SOL	250 MCM	2-1/16	3-1/4	3/8	1.05
1-OC-2656			300 MCM	500 MCM	2-3/4	3-1/2	1/2	2.15
1-OC-27X43	-	2	#8 SOL	#4 STR	1-15/16	3-5/16	3/8	1.10
1-OC-27X48			#4 SOL	2/0 STR	1-7/8	3-5/16	3/8	1.05
1-OC-27X51			2/0 SOL	250 MCM	2-1/16	3-5/16	3/8	1.30

GROUND CONNECTORS

TYPE 1-OC Continued

CATALOG NUMBER	PIPE SIZE		CONDUCTOR RANGE		DIMENSIONS - INCHES			WEIGHT (POUNDS)
	(NPS)	(O.D.)	MINIMUM	MAXIMUM	A	B	J	
1-OC-2748	2	2-3/8	#4 SOL	2/0 STR	1-13/16	3-5/8	3/8	1.05
1-OC-2751			2/0 SOL	250 MCM	2-1/16	3-5/8	3/8	1.25
1-OC-2756			300 MCM	500 MCM	2-5/8	4	1/2	1.95
1-OC-28X43	-	2-1/2	#8 SOL	#4 STR	1-3/4	3-3/8	3/8	1.45
1-OC-28X48			#4 SOL	2/0 STR	1-13/16	3-3/8	3/8	1.35
1-OC-28X51			2/0 SOL	250 MCM	2-1/8	3-7/8	3/8	1.95
1-OC-2843	2-1/2	2-7/8	#8 SOL	#4 STR	1-3/4	4-3/16	3/8	1.15
1-OC-2848			#4 SOL	2/0 STR	1-7/8	4-3/16	3/8	1.45
1-OC-2851			2/0 SOL	250 MCM	2-1/16	4-3/8	3/8	2.60
1-OC-2856			300 MCM	500 MCM	2-3/4	4-1/2	1/2	2.90
1-OC-29X48	-	3	#4 SOL	2/0 STR	1-7/8	3-3/4	3/8	1.70
1-OC-29X51			2/0 SOL	250 MCM	2-1/8	4-5/16	3/8	1.85
1-OC-29X56			300 MCM	500 MCM	2-9/16	5-3/16	1/2	2.95
1-OC-2948	3	3-1/2	#4 SOL	2/0 STR	2	4-13/16	3/8	1.75
1-OC-2951			2/0 SOL	250 MCM	2-1/8	4-13/16	3/8	2.90
1-OC-2956			300 MCM	500 MCM	3	5-3/16	1/2	4.15
1-OC-3043	3-1/2	4	#8 SOL	#4 STR	1-5/8	5-1/16	3/8	1.60
1-OC-3048			#4 SOL	2/0 STR	2	5-3/8	3/8	2.05
1-OC-3051			2/0 SOL	250 MCM	2-1/8	5-3/8	3/8	2.50
1-OC-3056			300 MCM	500 MCM	3	5-11/16	1/2	4.00
1-OC-3148	4	4-1/2	#4 SOL	2/0 STR	2	5-13/16	3/8	2.30
1-OC-3151			2/0 SOL	250 MCM	2-1/8	5-13/16	3/8	3.50
1-OC-3156			300 MCM	500 MCM	3	6-3/16	1/2	4.55

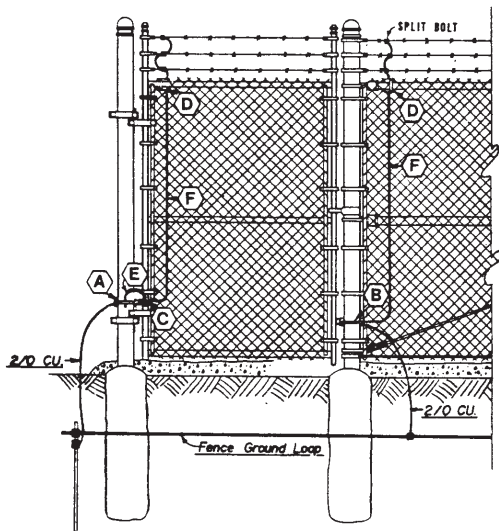

LEGEND

- A - Type GU1 Ground Clamp
- B - Type GU1 Ground Clamp
- C - Type 1-OC or GU1 Ground Clamp
- D - Type 1-OC Ground Clamp
- E - Type XBG Ground Strap
- F - No. 2 Tinned Copper Wire

TYPICAL GATE GROUNDING SCHEME

GROUND CONNECTORS

TYPE 2-OC

Two Cables
Parallel to Pipe

Casting Alloy: Electrical Bronze
Clamping Hardware: Silicon bronze

All-bronze ground connector for two cables parallel to NPS or O.D. fence post.
Note separate catalog numbers for some O.D. sizes.

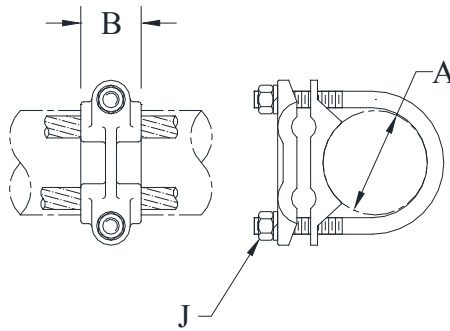

CATALOG NUMBER	PIPE SIZE		CONDUCTOR RANGE		DIMENSIONS - INCHES			WEIGHT (POUNDS)
	(NPS)	(O.D.)	MINIMUM	MAXIMUM	A (MAX)	B	J	
2-OC-2148	3/8	5/8 - 3/4	#4 SOL	2/0 STR	0.750	1-1/8	3/8	0.95
2-OC-2151			2/0 SOL	250 MCM	0.750	1-1/2	3/8	0.95
2-OC-2348	3/4	1	#4 SOL	2/0 STR	1.050	1-1/8	3/8	1.10
2-OC-2351			2/0 SOL	250 MCM	1.050	1-1/8	3/8	1.50
2-OC-2448	1	1-1/4	#4 SOL	2/0 STR	1.315	1-1/8	3/8	1.50
2-OC-2548	1-1/4	1-5/8	#4 SOL	2/0 STR	1.660	1-1/4	3/8	0.90
2-OC-2551			2/0 SOL	250 MCM	1.660	1-3/8	3/8	1.00
2-OC-2648	1-1/2	1-7/8	#4 SOL	2/0 STR	1.900	1-3/8	3/8	1.05
2-OC-2651			2/0 SOL	250 MCM	1.900	1-3/8	3/8	1.25
2-OC-27X48	-	2	#4 SOL	2/0 STR	2.000	1-3/8	3/8	1.00
2-OC-27X51			2/0 SOL	250 MCM	2.000	1-3/8	3/8	1.30
2-OC-2748	2	2-3/8	#4 SOL	2/0 STR	2.375	1-3/8	3/8	1.10
2-OC-2751			2/0 SOL	250 MCM	2.375	1-3/8	3/8	1.30
2-OC-2756			300 MCM	500 MCM	2.375	1-5/8	1/2	1.75
2-OC-28X51	-	2-1/2	2/0 SOL	250 MCM	2.500	1-3/8	3/8	1.35
2-OC-2848	2-1/2	2-7/8	#4 SOL	2/0 STR	2.875	1-3/8	3/8	1.10
2-OC-2851			2/0 SOL	250 MCM	2.875	1-3/8	3/8	1.35
2-OC-29X48	-	3	#4 SOL	2/0 STR	3.000	1-3/8	3/8	1.60
2-OC-29X51			2/0 SOL	250 MCM	3.000	1-1/2	3/8	1.45
2-OC-2948	3	3-1/2	#4 SOL	2/0 STR	3.500	1-3/8	3/8	1.20
2-OC-2951			2/0 SOL	250 MCM	3.500	1-1/2	3/8	1.90
2-OC-2956			300 MCM	500 MCM	3.500	1-5/8	1/2	2.80
2-OC-3048	3-1/2	4	#4 SOL	2/0 STR	4.000	1-3/8	3/8	3.15
2-OC-3051	3-1/2	4	2/0 SOL	250 MCM	4.000	1-3/8	3/8	3.15
2-OC-3148	4	4-1/2	#4 SOL	2/0 STR	4.500	1-3/8	3/8	3.20
2-OC-3151	4	4-1/2	2/0 SOL	250 MCM	4.500	1-1/2	3/8	3.20

GROUND CONNECTORS

TYPE GBR

Flexible Braid
Parallel to Pipe

All - bronze connector for clamping a Type XBG flexible copper grounding braid to NPS or O.D. fence post.
Used for grounding switch operating pipes and gate frames.

Casting Alloy: Electrical Bronze
Clamping Hardware: Silicon Bronze

CATALOG NUMBER	PIPE SIZE		DIMENSIONS - INCHES				WEIGHT (POUNDS)
	(NPS)	(O.D.)	A	B	C	J	
GBR-30	3/4	1	1-1/4	2-3/8	1	3/8	0.45
GBR-39	1	1-1/4	1-1/2	2-5/8	1-1/8	3/8	0.60
GBR-49	1-1/4	1-1/2	1-1/4	3	1-1/8	3/8	0.60
GBR-54	1-1/2	2	1-1/4	3-3/8	1-3/8	3/8	0.90
GBR-58	2	-	1-3/8	3-5/8	1-1/2	3/8	1.05
GBR-59	-	2-1/2	2	3-7/8	1-3/4	3/8	1.15
GBR-61	2-1/2	3	2	4-11/16	2-1/2	1/2	1.60
GBR-62	3	3-1/2	2	5-3/16	2-1/2	1/2	1.65
GBR-63	3-1/2	4	2-1/4	5-9/16	3	1/2	2.25
GBR-64	4	-	2-1/2	6-3/8	1-3/8	1/2	2.25
GBR-69	6	6-7/8	2-1/2	8-3/8	1-3/4	1/2	2.90

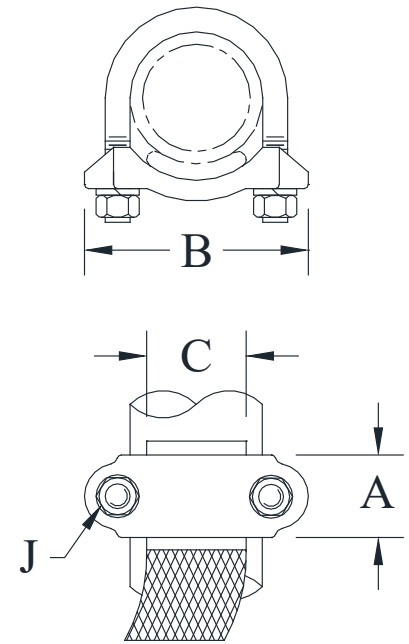

TYPE GCK

Parallel Connector
Single U-Bolt

All-bronze parallel clamp for static wire connections.
Top saddle is captive on U-bolt.

Casting Alloy: Electrical Bronze
Clamping Hardware: Silicon Bronze

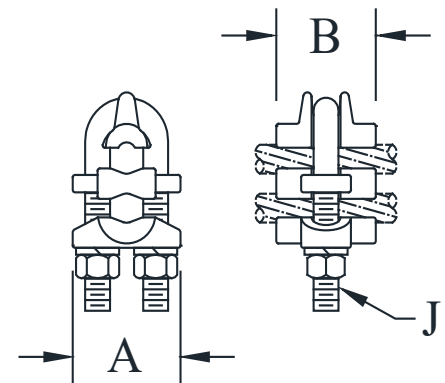

CATALOG NUMBER	CONDUCTOR RANGE (BOTH GROOVES)	DIMENSIONS - INCHES			WEIGHT (POUNDS)
		A	B	J	
GCK-4848	#2 SOL - 2/0 STR	1-5/8	1-1/2	3/8	0.75
GCK-5050	#1 STR - 4/0 STR	1-7/8	1-1/2	3/8	0.95
GCK-5252	1/0 SOL - 300 MCM	2	1-3/8	3/8	0.90
GCK-5656	4/0 SOL - 500 MCM	2-9/16	2-1/8	1/2	1.30

GROUND CONNECTORS

TYPE GF

Single Piece Clamp
Cable to Flat

A one-piece bronze ground clamp for single cable to flat copper or galvanized steel surface, with silicon bronze or galvanized steel hardware. Also available with stainless steel bolt and flat washer for use in tapped holes having UNC-2 fit. Add suffix (-T) to catalog number.

Casting Alloy: Electrical Bronze
Clamping Hardware: Silicon Bronze/Galvanized Steel

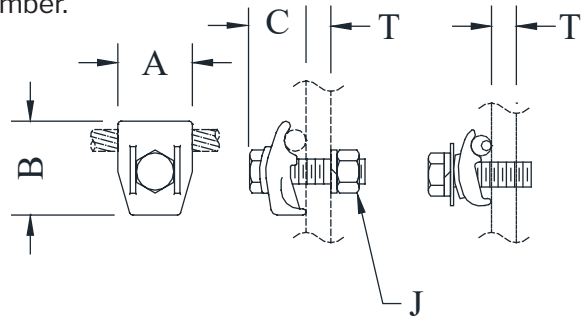

CATALOG NUMBER		CONDUCTOR RANGE	DIMENSIONS - INCHES					WEIGHT (POUNDS)
HARDWARE			A	B	C	J	T	
GALVANIZED	SILICON BRONZE							
GF-08	GF-08B	#4 SOL - 2/0 STR	1-1/2	1-5/8	1	1/2	3/8	0.40
*GF-09	**GF-09B	#4 SOL - 4/0 STR	1-1/8	1-9/16	1-1/16	3/8*	3/8	0.30
GF-12	GF-12B	#2 SOL - 250 MCM	1-1/2	1-7/8	1-1/8	1/2	1/2	0.50
GF-20	GF-20B	300 MCM - 500 MCM	1-7/8	2-1/8	1-7/16	1/2	1/2	0.75
GF-28	GF-28B	550 MCM - 750 MCM	1-1/2	2-5/8	1-3/4	1/2	1/2	1.00

* Uses galvanized steel carriage bolt. ** Uses silicon bronze carriage bolt.

TYPE GF2

Two Cables to Flat
Single-Piece Clamp

A one-piece bronze ground clamp for two cables of equal size to a flat copper or galvanized steel surface, available with silicon bronze or galvanized steel hardware. For galvanized steel flat washer in addition to the regular hardware, add suffix (-GW) to catalog number.

Castings: Electrical Bronze
Hardware: Silicon Bronze / Galvanized Steel

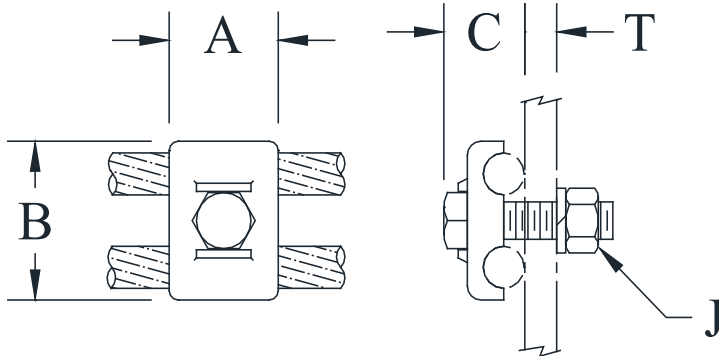

CATALOG NUMBER		CONDUCTOR RANGE	DIMENSIONS - INCHES					WEIGHT (POUNDS)
HARDWARE			A	B	C	J	T	
GALVANIZED	SILICON BRONZE							
GF2-08	GF2-08B	#4 SOL - 2/0 STR	1-1/2	1-7/8	1	1/2	3/8	0.40
GF2-11	GF2-11B	1/0 SOL - 4/0 STR	1-1/2	2-1/8	1-1/8	1/2	1/2	0.55
GF2-12	GF2-12B	#2 SOL - 250 MCM	1-7/8	2-3/8	1-1/4	5/8	5/8	0.85
GF2-20	GF2-20B	300 MCM - 500 MCM	2	2-3/4	1-1/4	1/2	7/16	0.95

GROUND CONNECTORS

TYPE GTT2

Two-Bolt Clamp

One or Two Cables to Flat

Casting Alloy: Electrical Bronze
Clamping Hardware: Silicon Bronze / Galvanized Steel

A two-bolt ground connector for two cables of equal or unequal diameters to flat copper or galvanized surface.

For T dimension greater than shown, add required thickness to catalog number. Example: GTT2-14-1/2.

Also available with stainless steel bolts and flat washers for use in tapped holes having class 2 fit. Add suffix (-T) to catalog number.

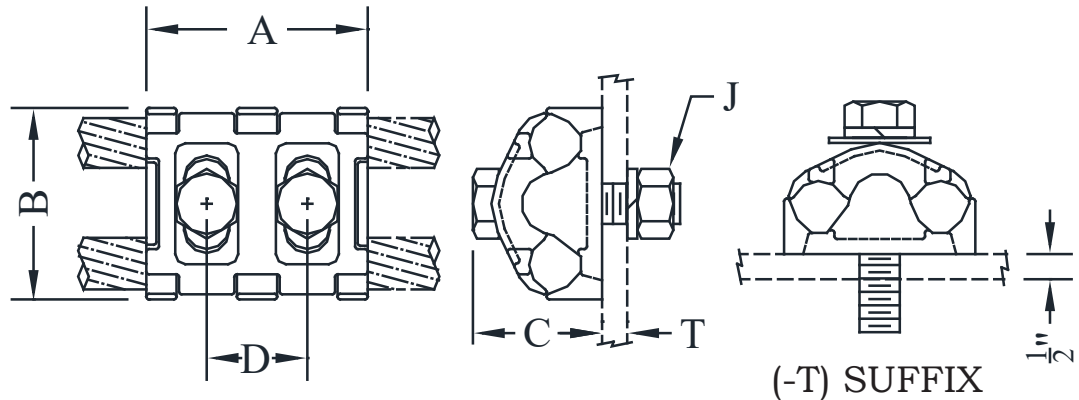

CATALOG NUMBER		CONDUCTOR RANGE	DIMENSIONS - INCHES						WEIGHT (POUNDS)
HARDWARE			A	B	C	D	J	T	
GALVANIZED	SILICON BRONZE								
GTT2-14	GTT2-14-B	#4 SOL - 300 MCM	2-3/4	2-3/8	1-5/8	1-1/4	1/2	5/16	1.40
GTT2-14-N	GTT2-14-N-B	#4 SOL - 300 MCM	3-1/4	2-3/8	1-5/8	1-3/4	1/2	5/16	1.50
GTT2-20	GTT2-20-B	300 - 500 MCM	2-3/4	2-7/8	1-3/4	1-1/4	1/2	1/2	1.90
GTT2-20-N	GTT2-20-N-B	1/0 SOL - 500 MCM	3-1/4	2-3/4	1-3/4	1-3/4	1/2	1/2	3.45

TYPE GLT-12

Equipment Grounding Terminal
Cable to Flat

Castings: Electrical Bronze
Hardware: Silicon Bronze / Galvanized Steel

A through-type grounding terminal for apparatus grounding pads having tapped holes on a NEMA 2-hole pattern.

Connector allows continuity of the ground conductor where required.

Conductor sizes: #6 STR through 250 MCM.

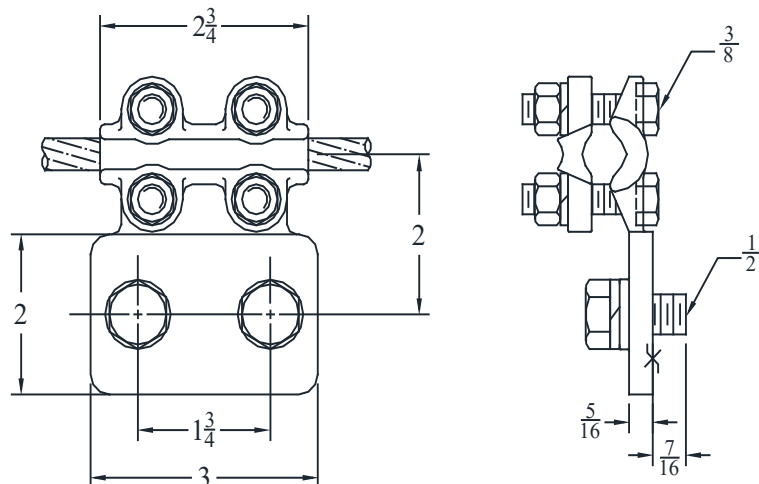

GROUND CONNECTORS

TYPE GTC

Single Cable to Flat
Two-Piece Clamp

Casting Alloy: Electrical Bronze
Clamping Hardware: Silicon Bronze /
Galvanized Steel

A two-piece ground connector for single cable to flat copper or galvanized steel surface, available with silicon bronze or galvanized steel hardware. For T dimension greater than shown, add required thickness as suffix to catalog number.

Example: GTC-14-1/2.

Also available with stainless steel bolt and flat washer for use in tapped holes having class 2 fit. Add suffix (-T) to catalog number.

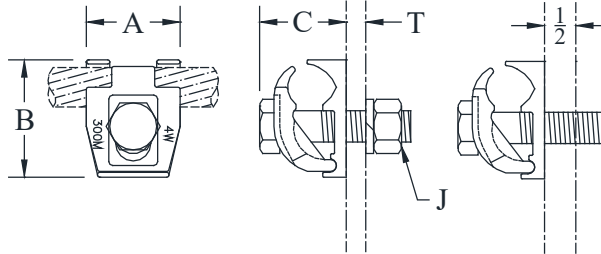

* Uses galvanized steel carriage bolt

CATALOG NUMBER		CONDUCTOR RANGE	DIMENSIONS - INCHES					WEIGHT (POUNDS)
HARDWARE			A	B	C	J	T	
GALVANIZED	SILICON BRONZE							
GTC-04	GTC-04B	#8 SOL - #4 STR	1	1-1/2	7/8	3/8	3/8	0.35*
GTC-09	GTC-09B	#4 SOL - 2/0 STR	1-1/4	1-3/4	1-1/2	1/2	1/2	0.70
GTC-14	GTC-14B	#4 SOL - 300 MCM	1-1/2	1-7/8	1-3/8	1/2	5/16	0.60
GTC-20	GTC-20B	300 MCM - 500 MCM	1-3/8	2-7/16	1-3/4	1/2	1/2	1.00
GTC-1020	GTC-1020B	4/0 SOL - 500 MCM	2	2-5/16	1-7/8	5/8	1/2	1.20

TYPE GTC2

One or Two Cables to Flat
Two-Piece Clamp

Casting Alloy: Electrical Bronze
Clamping Hardware: Silicon Bronze /
Galvanized Steel

A two-piece ground connector for one or two cables to flat copper or galvanized steel surface, available with silicon bronze or galvanized steel hardware.

For T dimension greater than shown, add required thickness as suffix to catalog number. Example: GTC2-14-1/2.

Also available with stainless steel bolt and flat washer for use in tapped holes having class 2 fit. Add suffix (-T) to catalog number.

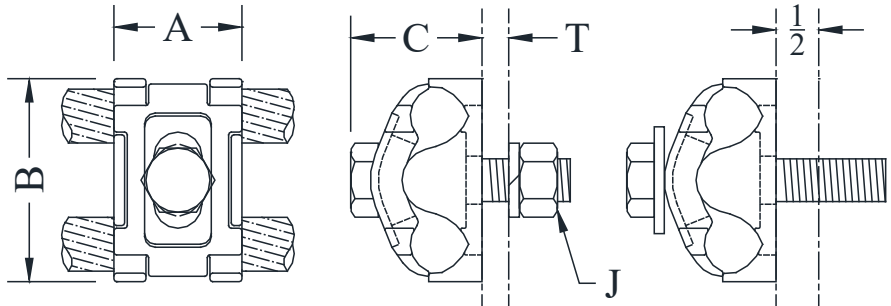

CATALOG NUMBER		CONDUCTOR RANGE	DIMENSIONS - INCHES					WEIGHT (POUNDS)
HARDWARE			A	B	C	J	T	
GALVANIZED	SILICON BRONZE							
GTC2-09A	GTC2-09A-B	#4 SOL - 2/0 STR	1-1/8	1-7/8	1-1/8	3/8	3/8	0.50
GTC2-14	GTC2-14B	#4 SOL - 300 MCM	1-5/8	2-7/16	1-5/8	1/2	5/16	0.75
GTC2-0520	GTC2-0520B	#2 STR - 500 MCM	1-3/4	2-3/4	1-3/4	1/2	1/2	1.25
GTC2-1020	GTC2-1020B	4/0 STR - 500 MCM	2	2-7/8	2	5/8	1/2	1.90

GROUND CONNECTORS

TYPE GU1

One or Two Cables
Parallel or 90° to Pipe

Casting Alloy: Electrical Bronze
Clamping Hardware: Silicon Bronze

A more universal type all-bronze ground connector for either one or two copper cables parallel or 90° to NPS or O.D. post.

The 90° position accommodates two cables of unequal size within the range listed. Sizes indicated by (*) will also accommodate a Type XBG gate-grounding strap under the connector saddle.

Note: Catalog numbers GU1-1809 and GU1-1812 will accommodate only one cable in the parallel position.

NOTE: CATALOG NUMBERS:

GU1-3912

GU1-4912

GU1-5412

GU1-5812

GU1-6012

GU1-6212

GU1-6312

WILL ACCOMMODATE THREE
EQUAL SIZE CONDUCTORS
PARALLEL TO ROD OR PIPE.
(WITH NOTED LIMITATIONS)

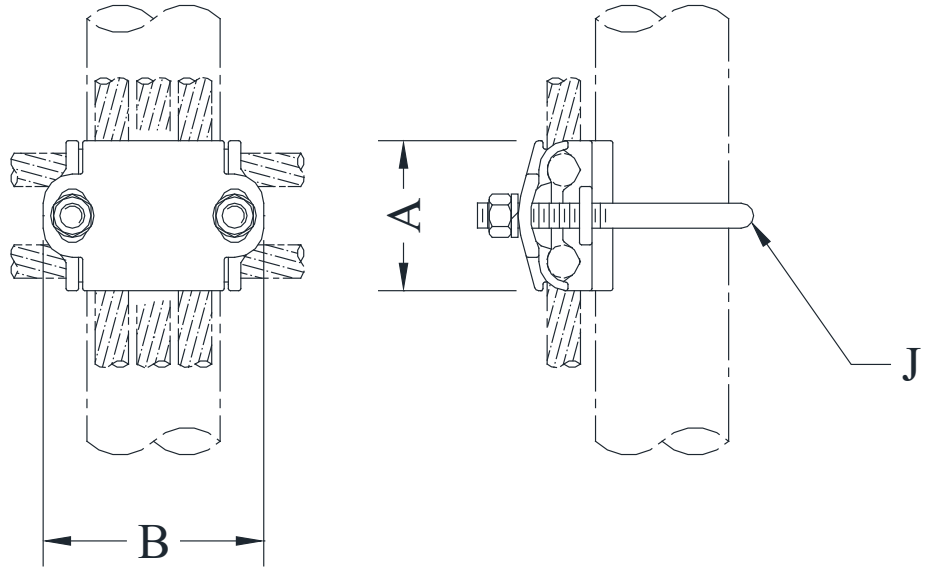

CATALOG NUMBER	PIPE SIZE		CONDUCTOR RANGE		DIMENSIONS - INCHES			WEIGHT (POUNDS)
	(NPS)	(O.D.)	MINIMUM	MAXIMUM	A (MAX)	B	J	
GU1-1809	3/8	1/2 - 3/4	#4 SOL	2/0 STR	1-5/8	2-1/8	3/8	0.90
GU1-1812			#2 SOL	250 MCM	2-1/2	2-1/8	3/8	1.25
GU1-3909	1	1-1/4	#4 SOL	2/0 STR	1-5/8	3-5/8	3/8	1.20
GU1-3912			2/0 SOL	250 MCM	2-1/4	3-5/8	3/8	1.75
GU1-4909	1-1/4	1-5/8	#4 SOL	2/0 STR	1-5/8	3	3/8	1.25
GU1-4912			#2 SOL	250 MCM	2-1/2	3	3/8	1.80
GU1-5409	1-1/2	2	#4 SOL	2/0 STR	1-5/8	3-5/16	3/8	1.65
GU1-5412			#2 SOL	250 MCM	2-1/4	3-5/16	3/8	1.80
GU1-5809	2	2-1/2	#4 SOL	2/0 STR	1-5/8	3-13/16	3/8	1.90
GU1-5812			2/0 SOL	250 MCM	2-1/4	3-3/4	3/8	1.55
GU1-6009*	2-1/2	3	#4 SOL	2/0 STR	1-5/8	4-5/16	3/8	1.95
GU1-6012*			#2 SOL	250 MCM	2-1/2	4-1/4	3/8	2.40
GU1-6209*	3	3-1/2	#4 SOL	2/0 STR	1-5/8	4-3/4	3/8	2.10
GU1-6212*			#2 SOL	250 MCM	2-1/2	4-13/16	3/8	2.55
GU1-6309*	3-1/2	4	#4 SOL	2/0 STR	1-5/8	5-5/16	3/8	2.25
GU1-6312*			#4 SOL	250 MCM	2-1/4	5-5/16	3/8	2.95

GROUND CONNECTORS

TYPE GUR

One or Two Cables
Parallel or 90° to Pipe

Casting Alloy: Electrical Bronze
Clamping Hardware: Silicon Bronze

A universal type all-bronze ground connector for either one or two copper cables parallel or 90° to NPS or O.D. post.

The three-piece design allows for the connector to be firmly bolted to the post without having to connect the copper cables. The copper cables can then be firmly bolted at a later time.

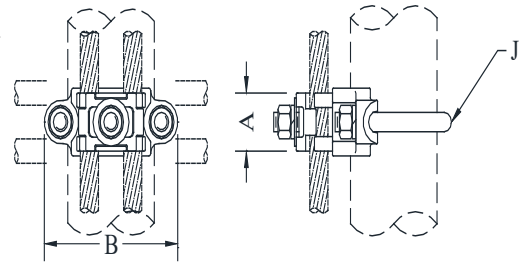

CATALOG NUMBER	PIPE SIZE		CONDUCTOR RANGE		DIMENSIONS - INCHES			WEIGHT (POUNDS)
	(NPS)	(O.D.)	MINIMUM	MAXIMUM	A (MAX)	B	J	
GUR-5804	2	2-1/2	#8 SOL	#4 STR	1-3/4	4-1/8	1/2	2.20
GUR-5809			#4 SOL	2/0 STR				2.35
GUR-5814			#4 SOL	300 MCM				2.60
GUR-5820			#2 STR	500 MCM				3.00
GUR-6004	2-1/2	3	#8 SOL	#4 STR	1-3/4	4-5/8	1/2	2.55
GUR-6009			#4 SOL	2/0 STR				2.70
GUR-6014			#4 SOL	300 MCM				2.90
GUR-6020			#2 STR	500 MCM				3.30
GUR-6204	3	3-1/2	#8 SOL	#4 STR	1-3/4	5-5/16	1/2	2.90
GUR-6209			#4 SOL	2/0 STR				3.05
GUR-6214			#4 SOL	300 MCM				3.25
GUR-6220			#2 STR	500 MCM				3.65
GUR-6304	3-1/2	4	#8 SOL	#4 STR	1-3/4	5-11/16	1/2	3.20
GUR-6309			#4 SOL	2/0 STR				3.35
GUR-6314			#4 SOL	300 MCM				3.55
GUR-6320			#2 STR	500 MCM				3.95
GUR-6404	4	4-1/2	#8 SOL	#4 STR	1-3/4	6-1/4	1/2	3.35
GUR-6409			#4 SOL	2/0 STR				3.50
GUR-6414			#4 SOL	300 MCM				3.85
GUR-6420			#2 STR	500 MCM				4.25
GUR-6704	5	5-1/2	#8 SOL	#4 STR	2	6-7/8	3/8	3.35
GUR-6709			#4 SOL	2/0 STR				3.45
GUR-6714			#4 SOL	300 MCM				3.65
GUR-6720			#2 STR	500 MCM				4.65
GUR-6904	6	6-5/8	#8 SOL	#4 STR	2	8-3/8	1/2	3.90
GUR-6909			#4 SOL	2/0 STR				4.20
GUR-6914			#4 SOL	300 MCM				4.40
GUR-6920			#2 STR	500 MCM				4.80
GUR-7004	-	8	#8 SOL	#4 STR	2	11-3/4	1/2	6.35
GUR-7009			#4 SOL	2/0 STR				6.75
GUR-7014			#4 SOL	300 MCM				6.40
GUR-7020			#2 STR	500 MCM				6.80
GUR-7014	8	8-11/16	#8 SOL	#4 STR	2	10-7/16	1/2	6.00
GUR-7109			#4 SOL	2/0 STR				6.15
GUR-7114			#4 SOL	300 MCM				6.05
GUR-7120			#2 STR	500 MCM				6.20

GROUND CONNECTORS

TYPE OF

Cable or Rod
To Flat Bar

All-Bronze ground connector for cable, rod, or pipe to flat bar, where continuous run of the conductor is required. Accommodates bar thickness shown.

Casting Alloy: Electrical Bronze
Clamping Hardware: Silicon Bronze

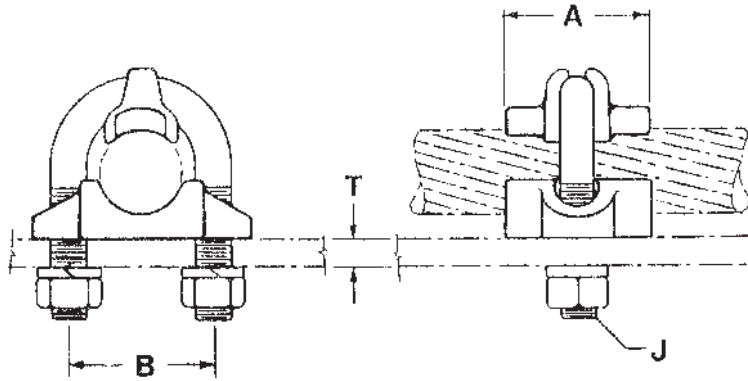

CATALOG NUMBER	CONDUCTOR RANGE	DIMENSIONS - INCHES				WEIGHT (POUNDS)
		A	B	J	T	
OF-24	1" NPS	1-1/2	1-3/4	3/8	1/2	0.50
OF-4750	1/0 STR - 4/0 STR	1-3/8	1-1/16	3/8	3/8	0.50
OF-4752	1/0 STR - 300 MCM	1-5/8	1-1/16	3/8	1/2	1.00
OF-5256	300 MCM - 500 MCM	1-5/8	1-1/4	3/8	1/2	1.40

TYPE PL

Parallel / Ground
Connector for Cable

Two Piece Bronze Connector for connecting copper cable, copper weld, guy strand or static wire.

Casting Alloy: Electrical Bronze
Clamping Hardware: Silicon Bronze

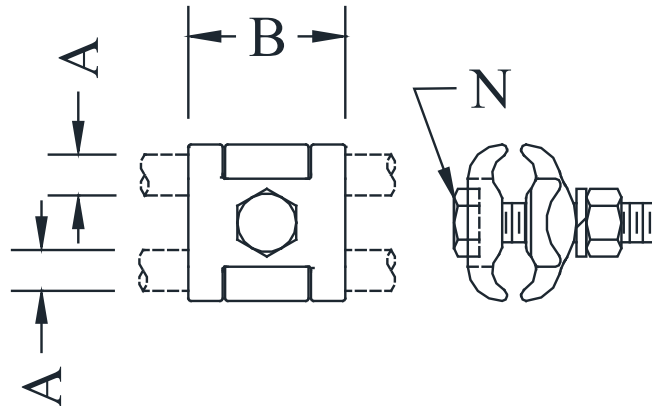

CATALOG NUMBER	CABLE RANGE (A)		DIMENSIONS - INCHES	
	MIN.	MAX	B	N
PL-50	#6 STR	4/0 STR	2	1/2
PL-52	2/0 STR	300 MCM	2	1/2
PL-56	300 MCM	500 MCM	2-1/8	5/8
PL-61	500 MCM	750 MCM	2-1/8	5/8

GROUND CONNECTORS

TYPE UN

Eye-Bolt Connector
Cable to Flat Pad

All-bronze ground connector for single cable to flat bar. For tin plating, add suffix (-SND) to catalog number. Not recommended for use with aluminum conductor.

Casting Alloy: Electrical Bronze
Clamping Hardware: Silicon Bronze
Eye-Bolt: Aluminum Bronze / Tinned

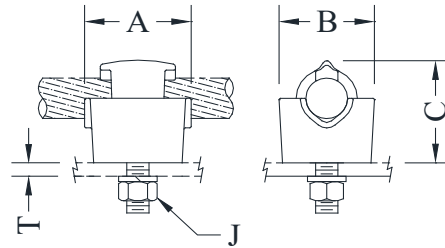

CATALOG NUMBER	CONDUCTOR RANGE	DIMENSIONS - INCHES					WEIGHT (POUNDS)
		A	B	C	J	T	
UN-4048	#8 SOL - 2/0 STR	1-3/4	1-1/4	1-9/16	1/2	5/16	0.55
UN-4048T						3/4	
UN-4151	#6 STR - 250 MCM	1-5/8	1-1/2	1-13/16	1/2	1/2	0.70
UN-4151T						1-1/8	
UN-4553	#2 SOL - 350 MCM	1-7/8	1-3/4	2-3/16	1/2	5/16	0.75
UN-4553T						3/4	
UN-4656	1/0 SOL - 500 MCM	2-1/8	2	2-1/2	5/8	5/16	1.00
UN-4656T						3/4	

TYPE UNN

Eye-Bolt Connector
One or Two Cable to Flat

All-bronze ground connector for use as single-cable double-grip or two-cable single-grip to flat to bar. For tin plating, add suffix (-SND) to catalog number. Not recommended for use with aluminum conductor.

Casting Alloy: Electrical Bronze
Clamping Hardware: Silicon Bronze
Eye-Bolt: Aluminum Bronze / Tinned

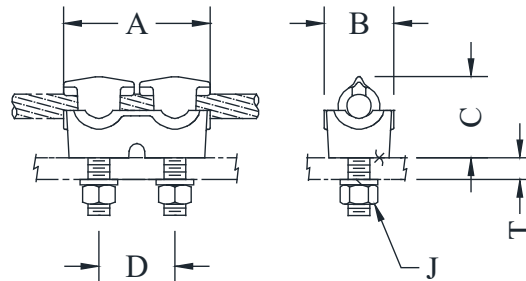

CATALOG NUMBER	CONDUCTOR RANGE	DIMENSIONS - INCHES						WEIGHT (POUNDS)
		A	B	C	D	J	T	
UNN-4048	#8 SOL - 2/0 STR	3-1/2	1-3/4	1-5/8	1-3/4	1/2	1/4	1.80
UNN-4048T							3/4	
UNN-4151	#6 STR - 250 MCM	3-1/2	1-3/4	1-7/8	1-3/4	1/2	5/16	1.50
UNN-4151T							3/4	
UNN-4553	#2 SOL - 350 MCM	3-5/8	1-7/8	2-3/16	1-3/4	1/2	5/16	1.65
UNN-4553T							3/4	
UNN-4656	1/0 SOL - 500 MCM	4-1/8	2-3/8	2-3/8	1-3/4	1/2	5/16	2.10
UNN-4656T							3/4	
*UNN-5361	350 MCM - 750 MCM	3-5/8	2-1/8	2-1/2	1-3/4	1/2	5/16	2.30
*UNN-5361T							3/4	

* Single-cable, double-grip only.

SEFCOR

GROUND CONNECTORS

TYPE OCS

Single Cable to H-Section
Fence Post
Parallel or 90°

All - bronze ground clamp for clamping a single cable parallel or 90° to H-section fence post.

Casting Alloy: Electrical Bronze
Clamping Hardware: Silicon Bronze

CATALOG NUMBER	POST SIZE (A x B)	CABLE RANGE	C	J	WEIGHT (POUNDS)
OCS-A48	1-3/8 x 1-1/2	#4 SOL - 2/0 STR	1-7/8	3/8	1.10
OCS-A51	1-3/8 x 1-1/2	2/0 SOL - 250 MCM	2-1/8	3/8	0.75
OCS-B48	2 x 2	#4 SOL - 2/0 STR	1-7/8	3/8	1.40
OCS-C48	2 x 2-1/4	#4 SOL - 2/0 STR	1-7/8	3/8	1.30
OCS-C51	2-1/4 x 2-1/4	2/0 SOL - 250 MCM	2-1/8	3/8	2.00
OCS-C56	2 x 2-1/4	300 - 500 MCM	2-5/8	3/8	2.35
OCS-D51	2 x 2-1/2	2/0 SOL - 250 MCM	2-1/8	3/8	2.20

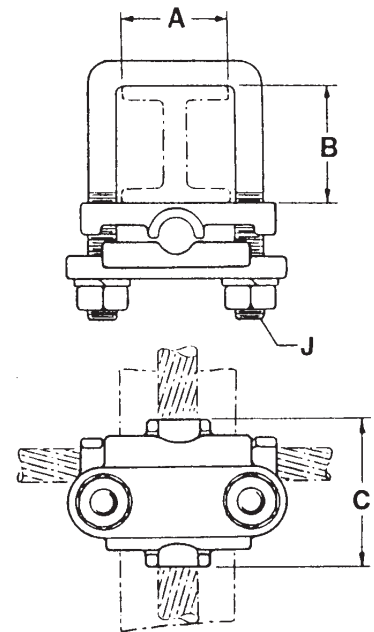

TYPE XBG

Grounding Strap
Flexible Braid

Flexible tinned copper grounding strap for use with Types GBR, and GU1 ground clamps.

Ferrules are solder-dipped after pressing, to form a solidly bonded mass full length of the ferrule.

Ferrule surfaces are tinned.

Additional strap lengths (L) may be obtained by substituting the required dimension (in inches) in catalog number.

Braid: Tinned Copper
Ferrules: Tinned Copper

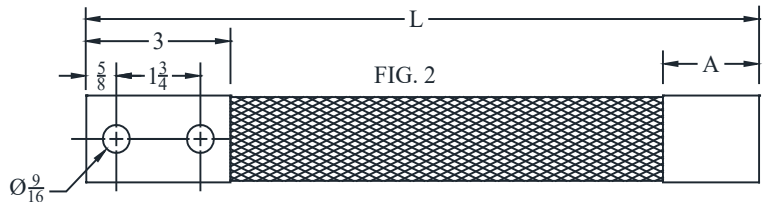
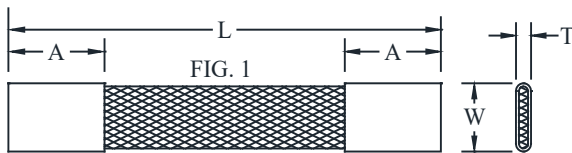

CATALOG NUMBER	FIG. NO.	CIRCULAR MILS.	DIMENSIONS - INCHES				WEIGHT (POUNDS)
			A	L	T	W	
XBG76-B-12	1	77,000	2-1/4	12	3/16	7/8	0.40
XBG76-B-18	1	77,000	2-1/4	18	3/16	7/8	0.55
XBG76-B-24	1	77,000	2-1/4	24	3/16	7/8	0.65
XBG76-D-18	2	76,400	3	18	3/16	1-1/16	0.60
XBG76-D-24	2	76,400	3	24	3/16	1-1/16	0.75
XBG146-B-18	1	150,000	2-1/4	18	5/16	1-3/8	1.10
XBG146-B-24	1	150,000	2-1/4	24	5/16	1-3/8	1.35
XBG146-D-18	2	150,000	3	18	5/16	1-3/8	1.20
XBG146-D-24	2	150,000	3	24	5/16	1-3/8	1.45
XBG146-D-30	2	150,000	3	30	5/16	1-5/8	1.70

GROUND CONNECTORS

TYPE XB2N/XB4N

Flexible Braid Shunt

Flexible tinned copper braid shunt.

Available with two or four holes NEMA drilled pads.

(L)=Overall length in inches.

EXAMPLE: XB2N-145-18

Braid: Tinned Copper
Ferrules: Tinned Copper

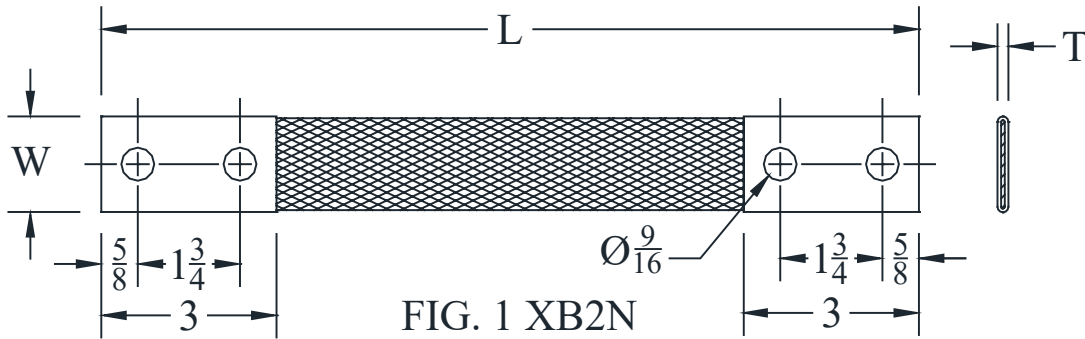

FIG. 1 XB2N

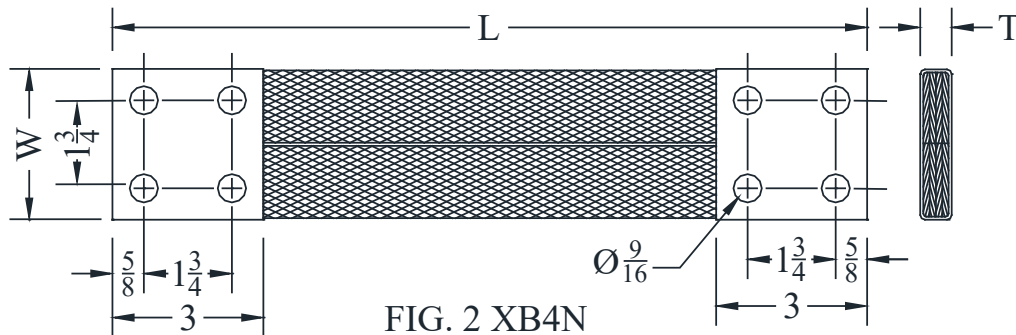

FIG. 2 XB4N

CATALOG NUMBER	FIG. NO.	AMPERE RATINGS		DIMENSIONS - INCHES			WEIGHT (POUNDS)
		INDOOR	OUTDOOR	L	T	W	
XB2N-76-(L)	1	225 A.	300 A.	To Be Specified By Customer	3/16	1-1/16	Refer To Factory
XB2N-145-(L)	1	380 A.	475 A.		3/16	1-5/8	
XB2N-152-(L)	1	375 A.	485 A.		5/16	1-1/4	
XB2N-291-(L)	1	500 A.	640 A.		5/16	1-5/8	
XB2N-437-(L)	1	600 A.	760 A.		1/2	1-5/8	
XB2N-583-(L)	1	680 A.	810 A.		1/2	1-3/4	
XB2N-876-(L)	1	1000 A.	1200 A.		3/4	1-3/4	
XB4N-291-(L)	2	600 A.	780 A.		1/4	3	
XB4N-583-(L)	2	800 A.	1000 A.		5/16	3	
XB4N-875-(L)	2	1000 A.	1260 A.		1/2	3	
XB4N-1168-(L)	2	1200 A.	1500 A.	5/8	3		

ALUMINUM COMPRESSION CONNECTORS



AL



AL-EHV



QCT-HV



AL2



ATCF



ATCF-EHV



ATCC



ATCC-EHV



ARS

AS

COPPER COMPRESSION CONNECTORS



CL



CTCC



CS



CTCF

COMPRESSION CONNECTORS

TYPE AL

(Hex Die)

Compression Terminal
Aluminum Cable to Flat

Pure aluminum compression terminal for aluminum cable to flat NEMA pad. Terminals are for use with hex dies only and should not be used with circular dies. Contact sealant is factory applied in the barrel and the connector is sealed in a clear plastic bag. Optional suffixes include the following:

- S: Short Barrel Design
- TTP: Ship with an AL/CU transition plate for pad
- WOI: Ship without oxide inhibitor in barrel
- MBFN: Include captive mounting bolts and flange nuts

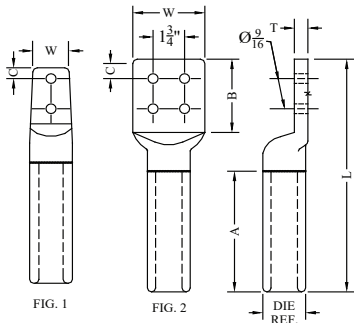
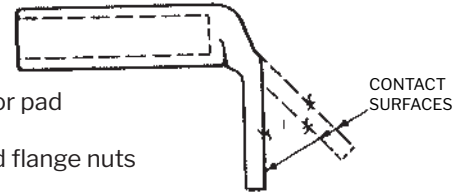

Angle connector may be obtained by adding desired angle to catalog number.
Example: AL-677-2B-15

Two cable to flat connection is also available. These are two compressions forming to a single 4 hole NEMA pad. See illustrations on pages 273 and 290.
Example: AL2-677-4A

CATALOG NUMBER	FIG. NO.	CONDUCTOR SIZE (MCM)		DIE REF	DIMENSION-INCHES						WEIGHT (POUNDS)
		AAC	ACSR		A	B	C	L	T	W	
AL-292-2A	1	#2 (7)(19)	#3 (6/1)	.640 73AH 243	2	3-1/4	5/8	6-1/16	1/4	1-3/16	0.15
AL-316-2A	1	-----	#2 (6/1)		2	3-1/4	5/8	6-1/16	1/4	1-3/16	0.15
AL-332-2A	1	#1 (7)(19)	#2 (7/1)		2	3-1/4	5/8	6-1/16	1/4	1-3/16	0.15
AL-355-2B	1	-----	#1 (6/1)	.840 74AH 249	3	3-1/4	5/8	7-1/2	5/16	2	0.25
AL-373-2B	1	1/0 (7)(19)	-----		3	3-1/4	5/8	7-1/2	5/16	2	0.35
AL-398-2B	1	-----	1/0 (6/1)		3	3-1/4	5/8	7-1/2	5/16	2	0.35
AL-419-2B	1	2/0 (7)(19)	-----		3	3-1/4	5/8	7-1/2	5/16	2	0.35
AL-447-2B	1	-----	2/0 (6/1)		3	3-1/4	5/8	7-1/2	5/16	2	0.30
AL-470-2B	1	3/0 (7)(19)(37)	-----		3	3-1/4	5/8	7-1/2	5/16	2	0.35
AL-502-2B	1	-----	3/0 (7)(19)		3	3-1/4	5/8	7-1/2	5/16	2	0.35
AL-528-2B	1	4/0 (7)(19)	-----		3	3-1/4	5/8	7-1/2	5/16	1-1/2	0.30
AL-528-4A	2				3	3-1/4	5/8	7-1/2	5/16	3	0.45
AL-563-2B	1	-----	4/0 (6/1)		3	3-1/8	5/8	7-1/4	3/8	2	0.30
AL-563-4A	2				3	3-1/4	5/8	7-1/2	5/16	3	0.45
AL-575-2B	1	250 (7)(19)(37)	-----		3-1/2	3-1/4	5/8	8-1/8	3/8	2	0.60
AL-575-4A	2				3-1/4	3-1/4	5/8	8-1/4	5/16	3	0.65
AL-593-2B	1	266.8 (7)(19)	-----		3-1/2	3-1/4	5/8	8-1/8	3/8	2	0.60
AL-593-4A	2				3-1/2	3-1/4	5/8	8-1/8	5/16	3	0.65
AL-609-2B	1	-----	266 (18/1)	1.125 76AH 316	3-1/2	3-1/4	5/8	8-1/8	3/8	2	0.60
AL-609-4A	2				3-1/2	3-1/4	5/8	8-1/8	5/16	3	0.65
AL-633-2B	1	300	266 (24/7) (22/7)(6/7)		3-1/2	3-1/4	5/8	8-1/8	3/8	2	0.60
AL-633-4A	2				3-1/2	3-1/4	5/8	8-1/8	5/16	3	0.65
AL-646-2B	1	-----	266 (26/7) 300 (18/1)		3-1/2	3-1/4	5/8	8-1/8	3/8	2	0.60
AL-646-4A	2				3-1/2	3-1/4	5/8	8-1/8	5/16	3	0.65
AL-677-2B	1	336 (19)(37)	336 (36/1) 266 (30/7)		3-1/2	3-1/4	5/8	8-1/4	3/8	2	0.55
AL-677-4A	2				4	3-1/4	5/8	8-5/8	5/16	3	0.65

Continued on next page

COMPRESSION CONNECTORS

TYPE AL CONTINUED

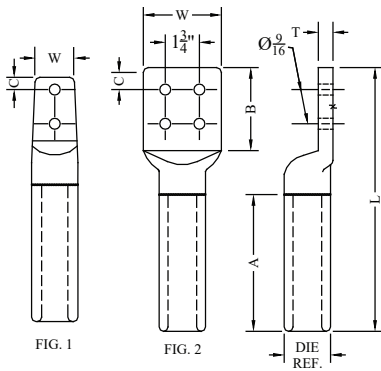

Type AL-EHV terminal used for high voltage applications where streamlined, tapered connectors are needed for corona free service. Add "EHV" to standard catalog number.
Example: AL-1031-4B-EHV

TYPE AL-EHV

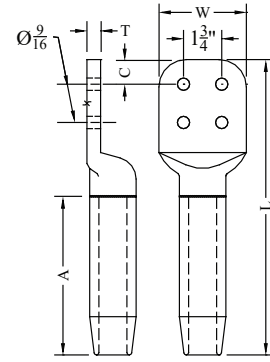

CATALOG NUMBER	FIG. NO.	CONDUCTOR SIZE (MCM)		DIE REF	DIMENSION-INCHES						WEIGHT (POUNDS)
		AAC	ACSR		A	B	C	L	T	W	
AL-684-2B	1	350 (19)	300 (26/7)	1.312 20AH 317	4	3-1/2	5/8	9	1/2	2	0.90
AL-684-4A	2	(37)(61)	336.4 (18/1)		4	3-1/4	5/8	9	3/8	3	0.95
AL-724-2B	1	397.5	300 (30/7)		4	3-1/4	5/8	8-3/4	1/2	2	0.85
AL-724-4A	2		336.4 (26/7)		4	3-1/4	5/8	9	3/8	3	0.95
AL-724-4B	2		(22/7)(24/7)		5	4-1/4	1-1/8	10-3/4	5/16	4	1.15
AL-736-2B	1	400 (19) (37)	397.5 (36/1)		4	3-1/4	5/8	8-3/4	1/2	2	0.85
AL-736-4A	2				4	3-1/4	5/8	9	3/8	3	0.90
AL-736-4B	2				5	4-1/4	1-1/8	10-3/4	5/16	4	1.00
AL-743-2B	1	-----	336.4 (30/7) 397.5 (18/1)		4	3-1/4	5/8	9	1/2	2	0.90
AL-743-4A	2				5	3-1/4	5/8	9-3/4	3/8	3	1.10
AL-743-4B	2				5	4-1/4	1-1/8	10-3/4	5/16	4	1.15
AL-783-2B	1	450 (19) (37)	397.5 (20/7) (22/7)(24/7) (26/7)		4	3-1/4	5/8	9	1/2	2	0.85
AL-783-4A	2				4	3-1/4	5/8	9	3/8	3	0.90
AL-783-4B	2				5	4-1/4	1-1/8	10-3/4	5/16	4	1.10
AL-795-2B	1	477 (19) (37)	-----		5	3-1/4	5/8	9-3/4	1/2	2	0.90
AL-795-4A	2				5	3-1/4	5/8	10	3/8	3	0.95
AL-795-4B	2				5	4-1/4	1-1/8	11	5/16	4	1.15
AL-814-2B	1	500 (19) (37)	397.5 (30/7) 477 (18/1) (36/1)		5	3-1/2	5/8	10	1/2	2	0.90
AL-814-4A	2				5	3-1/4	5/8	10	3/8	3	0.95
AL-814-4B	2				5	4-1/4	1-1/8	10-3/4	5/16	4	1.10
AL-846-2B	1	-----	477 (20/7) (22/7)(24/7)	4	3-1/4	5/8	8-3/4	1/2	2	0.80	
AL-846-4A	2			5	3-1/4	5/8	9-3/4	3/8	3	1.00	
AL-846-4B	2			5	4-1/4	1-1/8	10-3/4	5/16	4	1.10	
AL-858-2B	1	556.5 (19)(37)	477 (26/7)	5	3-1/4	5/8	9-3/4	1/2	2	0.85	
AL-858-4A	2			5	3-1/4	5/8	9-3/4	3/8	3	0.90	
AL-858-4B	2			5	10-3/4	1-1/8	10-3/4	5/16	4	1.00	

Continued on next page

COMPRESSION CONNECTORS

TYPE AL CONTINUED

TYPE AL-EHV

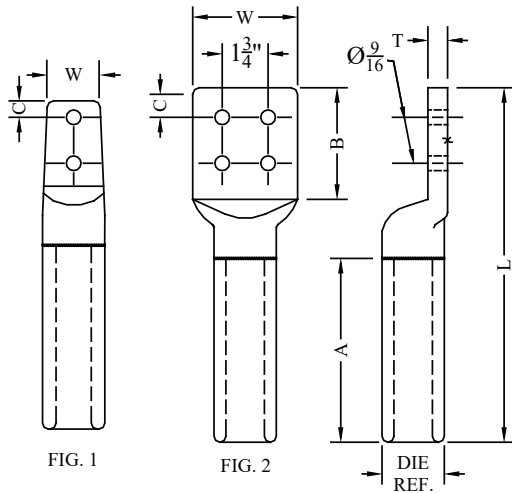
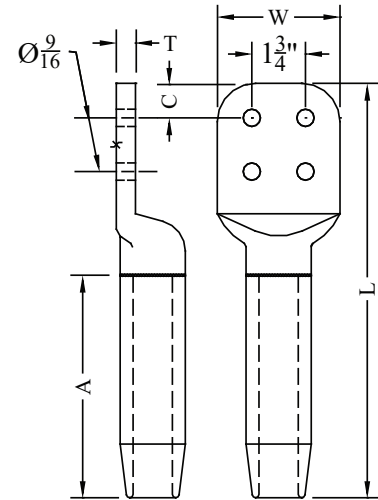

FIG. 1

FIG. 2

Type AL-EHV terminal used for high voltage applications where streamlined, tapered connectors are needed for corona free service. Add "EHV" to standard catalog number.

Example: AL-1031-4B-EHV



CATALOG NUMBER	FIG. NO.	CONDUCTOR SIZE (MCM)		DIE REF	DIMENSION-INCHES						WEIGHT (POUNDS)
		AAC	ACSR		A	B	C	L	T	W	
AL-883-2B	1		477 (30/7)	1.500 24AH 261	5	3-1/4	5/8	9-3/4	1/2	2	1.10
AL-883-4A	2	-----	556.5 (18/1) (36/1)		5	3-1/4	5/8	9-3/4	7/16	3	1.20
AL-883-4B	2				5	4-1/4	1-1/8	10-3/4	5/16	4	1.30
AL-893-2B	1				5	3-1/4	5/8	9-3/4	1/2	2	1.10
AL-893-4A	2	600	-----		5	3-1/4	5/8	9-3/4	7/16	3	1.20
AL-893-4B	2				5	4-1/4	1-1/8	10-3/4	5/16	4	1.30
AL-918-2B	1		500 (30/7)		5	3-1/4	5/8	9-3/4	1/2	2	1.10
AL-918-4A	2	636 (37) (61)	556.5 (22/7) (24/7)		5	3-1/4	5/8	9-3/4	7/16	3	1.15
AL-918-4B	2		605 (36/1)		5	4-1/4	1-1/8	10-3/4	5/16	4	1.30
AL-940-2B	1		556.5 (26/7)		5	3-1/4	5/8	9-3/4	1/2	2	1.50
AL-940-4A	2	650 (37) (61)(91)	636 (18/1) (36/1)		5	3-1/4	5/8	9-3/4	7/16	3	1.15
AL-940-4B	2				5	4-1/4	1-1/8	10-3/4	5/16	4	1.25
AL-966-2B	1		605 (24/7)		5	3-1/4	5/8	9-3/4	1/2	2	1.00
AL-966-4A	2	700 (37) (61)(91)	(26/7)		5	3-1/4	5/8	9-3/4	7/16	3	1.20
AL-966-4B	2		556 (30/7)		5	4-1/4	1-1/8	10-3/4	5/16	4	1.25
AL-987-2B	1		636 (24/7)		5	3-1/4	5/8	9-3/4	1/2	2	1.00
AL-987-4A	2	715 (37) (61)	(54/7)		5	3-1/4	5/8	9-3/4	7/16	3	1.10
AL-987-4B	2		715 (36/1)		5	4-1/4	1-1/8	10-3/4	3/8	4	1.35
AL-1000-2B	1		605 (30/7) (30/19)		5	3-1/4	5/8	9-3/4	1/2	2	1.00
AL-1000-4A	2	750 (37) (61)(91)	636 (26/7) (30/7)		5	3-1/4	5/8	9-3/4	7/16	3	1.10
AL-1000-4B	2		666.6 (24/7) (54/7)	5	4-1/4	1-1/8	11-1/8	5/16	4	1.30	

COMPRESSION CONNECTORS

TYPE AL CONTINUED

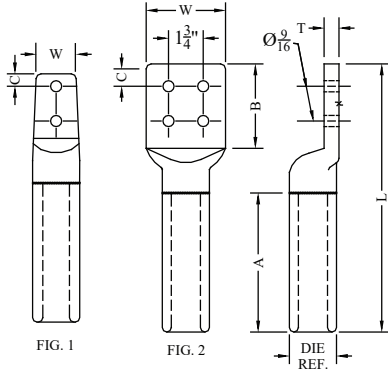

Type AL-EHV terminal used for high voltage applications where streamlined, tapered connectors are needed for corona free service.
Add "EHV" to standard catalog number.
Example: AL-1031-4B-EHV

TYPE AL-EHV

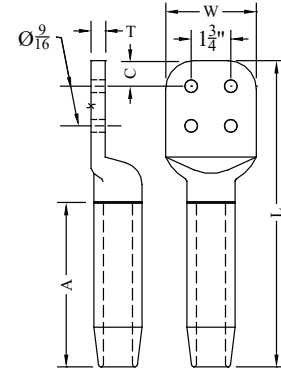

CATALOG NUMBER	FIG. NO.	CONDUCTOR SIZE (MCM)		DIE REF	DIMENSION-INCHES						WEIGHT (POUNDS)
		AAC	ACSR		A	B	C	L	T	W	
AL-1031-4A	2	795 (37)(61)	636 (30/19)	1.843 30AH 292	5	3-1/4	5/8	9-3/4	5/8	3	1.95
AL-1031-4B	2	800 (61)(91)	666.6 (26/7)		5	4-1/4	1-1/8	11-1/8	1/2	4	2.15
AL-1040-4A	2	-----	715 (54/7)		5	3-1/4	5/8	9-3/4	1/2	3	2.00
AL-1040-4B	2	-----	795 (36/1)		5	4-1/4	1-1/8	11-1/8	1/2	4	2.15
AL-1063-4A	2	-----	715.5 (26/7)	1.843 30AH 292	6	3-1/4	5/8	11-1/8	1/2	3	1.95
AL-1063-4B	2	-----	795 (20/7)(42/7) (45/7)		6	4-1/4	1-1/8	12-1/8	1/2	4	2.30
AL-1094-4A	2	874.5 - 900	715.5 (30/19)		6	3-1/4	5/8	11-1/8	1/2	3	1.90
AL-1094-4B	2		795 (22/7)(24/7) (54/7)		6	4-1/4	1-1/8	12-1/8	1/2	4	2.30
AL-1108-4A	2	927.2	795 (26/7)		6	3-1/4	5/8	11-1/8	1/2	3	1.90
AL-1108-4B	2				6	4-1/4	1-1/8	12-1/8	1/2	4	2.25
AL-1126-4A	2	954	-----		6	3-1/4	5/8	11-1/8	1/2	3	1.90
AL-1126-4B	2				6	4-1/4	1-1/8	12-1/8	1/2	4	2.25
AL-1152-4A	2	1000 (37)(61) (91)	795 (30/19)(30/7)		6	3-1/4	5/8	11-1/8	1/2	3	1.85
AL-1152-4B	2		874.5 (54/7)		6	4-1/4	1-1/8	12-1/8	1/2	4	2.20
AL-1172-4A	2	1033.5	900 (54/7)	2.125 34AH 575	7	3-1/4	5/8	12-1/4	3/4	3	3.00
AL-1172-4B	2		954 (45/7)		7	4-1/4	1-1/8	13-1/4	5/8	4	3.35
AL-1186-4A	2	-----	954 (20/7)(48/7)		7	3-1/4	5/8	12	3/4	3	2.95
AL-1186-4B	2		1033.5 (36/1)		7	4-1/4	1-1/8	13-1/4	5/8	4	3.35
AL-1196-4A	2	-----	954 (24/7)(54/7)		7	3-1/4	5/8	12	3/4	3	2.95
AL-1196-4B	2				7	4-1/4	1-1/8	13-1/4	5/8	4	3.30
AL-1216-4A	2	1100 1113	1033.5 (42/7)		7	3-1/4	5/8	12	3/4	3	2.95
AL-1216-4B	2		(45/7)		7	4-1/4	1-1/8	13-1/4	5/8	4	3.30

Continued on next page

COMPRESSION CONNECTORS

TYPE AL CONTINUED

CATALOG NUMBER	FIG. NO.	CONDUCTOR RANGE		DIE REF.	DIMENSIONS - INCHES						WEIGHT (POUNDS)	
		AAC	ACSR		A	B	C	L	T	W		
AL-1246-4A	2	-----	954 (30/19)	2.125 34AH 575	7	3-1/4	5/8	12	3/4	3	2.85	
AL-1246-4B	2		1033.5 (54/7)		7	4-1/4	1-1/8	13-1/4	5/8	4	3.25	
AL-1264-4A	2	1192.5 (61) 1200	1113 (45/7)(48/7)		7	3-1/4	5/8	12	3/4	3	2.85	
AL-1264-4B	2				7	4-1/4	1-1/8	13-1/4	5/8	4	3.20	
AL-1293-4A	2	1250	1113 (54/19)		2.375 38AH 478, 728	7	3-1/4	5/8	12-1/2	3/4	3	3.75
AL-1293-4B	2		1192.5(36/7)(42/7)			7	4-1/4	1-1/8	13-1/2	3/4	4	4.25
AL-1302-4A	2	1272	1192.5 (45/7)(48/7)			7	3-1/4	5/8	12-1/2	3/4	3	3.70
AL-1302-4B	2		1272 (36/1)			7	4-1/4	1-1/8	13-1/2	3/4	4	4.25
AL-1345-4A	2	1351 (61)	1192.5 (54/19)			7	3-1/4	5/8	12-1/2	3/4	3	3.65
AL-1345-4B	2		1272 (45/7)(42/7)			7	4-1/4	1-1/8	13-1/2	3/4	4	4.20
AL-1385-4A	2	1431 (61)	1272 (48/7)(54/19)			7	3-1/4	5/8	12-1/2	3/4	3	3.60
AL-1385-4B	2		1351.5 (45/7)(42/7)			7	4-1/4	1-1/8	13-1/2	3/4	4	4.10
AL-1417-4A	2	1500 1510.5 (91)	1431 (42/7)	7		3-1/4	5/8	12-1/2	3/4	3	3.55	
AL-1417-4B	2			7		4-1/4	1-1/8	13-1/2	3/4	4	4.00	
AL-1427-4A	2	-----	1351.5 (54/19)	7		3-1/4	5/8	12-1/2	3/4	3	4.00	
AL-1427-4B	2		1431 (45/7)(48/7)	7		4-1/4	1-1/8	13-1/2	3/4	4	4.00	
AL-1466-4A	2	1590(61)(91)	1431 (54/19)	7	3-1/4	5/8	12-1/2	3/4	3	3.45		
AL-1466-4B	2		1510.5 (45/7)	7	4-1/4	1-1/8	13-1/2	3/4	4	4.00		
AL-1506-4A	2	1700	1510.5 (54/19)	7	3-1/4	5/8	12	3/4	3	3.40		
AL-1506-4B	2		1590 (42/7)	7	4-1/4	1-1/8	13-1/2	3/4	4	3.95		
AL-1526-4B	2	1750	1590 (48/7)	7	4-1/4	5/8	13-1/2	3/4	4	3.90		
AL-1548-4B	2	1750 - 1800	1590 (54/19)	7	4-1/4	1-1/8	13-1/2	3/4	4	3.85		
AL-1602-4A	2	-----	1843 (72/7)	7	3-1/4	5/8	13-1/2	3/4	3	3.20		
AL-1602-4B	2		1869 (68/7)	7	4-1/4	1-1/8	13-1/2	3/4	4	3.75		
AL-1632-4B	2	2000	-----	7	4-1/4	1-1/8	13-1/2	3/4	4	3.70		
AL-1737-4B	2	2250	2167 (72/7)	7	4-1/4	1-1/8	15-1/4	1	4	6.70		
AL-1762-4B	2	2303.5	2156 (84/19)	9	4-1/4	1-1/8	15-1/4	1	4	6.60		
AL-1802-4B	2	-----	2306.2 (76/19)	9	4-1/4	1-1/8	15-1/4	1	4	6.50		
AL-1824-4B	2	2500	2300 (84/19)	9	4-1/4	1-1/8	15-1/4	1	4	6.45		
AL-1880-4B	2	-----	2385 (72/7)	9	4-1/4	1-1/8	15-1/4	1	4	6.35		
AL-1913-4B	2	2750	2515 (76/19)	9	4-1/4	1-1/8	15-1/4	1	4	6.05		
AL-1998-4B	2	3000	-----	9	4-1/4	1-1/8	15-1/4	1	4	6.00		
AL-2158-4B	2	3500	-----	9	4-1/4	1-1/8	15-1/4	1	4	5.50		
AL-2250-4B	2	3640	-----	9	4-1/4	1-1/8	15-1/4	1	4	5.45		
AL-2283-4B	2	4000	3364 (108/37)	9	4-1/4	1-1/8	15-1/4	1	4	5.10		
AL-2400-4B	2	4327	-----	9	4-1/4	1-1/8	15-1/4	1	4	4.80		

COMPRESSION CONNECTORS

TYPE AL

(Circular Die)
Compression Terminal
Aluminum Cable to Flat

Pure aluminum compression terminal for aluminum cable to flat NEMA pad. Terminals are for use with hex dies only and should not be used with circular dies. Contact sealant is factory applied in the barrel and the connector is sealed in a clear plastic bag.

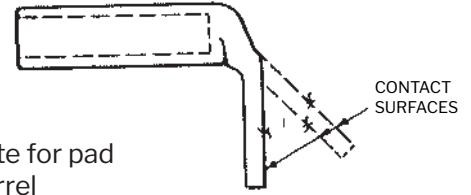
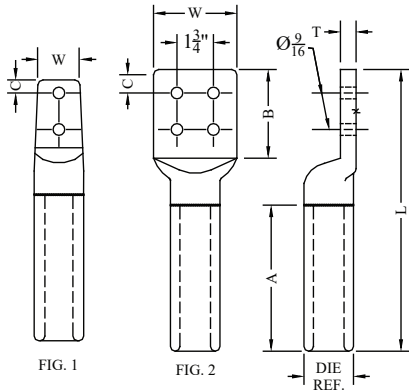

Optional suffixes include the following:

- S: Short Barrel Design
- TTP: Ship with an AL/CU transition plate for pad
- WOI: Ship without oxide inhibitor in barrel
- MBFN: Include captive mounting bolts and flange nuts

Angle connector may be obtained by adding desired angle to catalog number.
Example: (AL-677-2B-15)

Two cable to flat connection is also available. These are two compressions forming to a single 4 hole NEMA pad. See illustrations on pages 273 and 290.
Example: AL2-677-4A

CATALOG NUMBER	FIG. NO.	CONDUCTOR SIZE (MCM)		DIE REF	DIMENSION-INCHES						WEIGHT (POUNDS)
		AAC	ACSR		A	B	C	L	T	W	
AL-70-2B	1	300	266.8 (6/7)(18/1)(22/7)	07 CD	3	3-1/4	5/8	7-5/8	3/8	2	0.50
AL-70-4A	2	336.4 350	(24/7)(26/7)(30/7) 300 (26/7)		3	3-1/4	5/8	7-5/8	5/16	3	0.60
AL-80-2B	1	397.5 400	336.4 (18/1)(20/7)(22/7) (24/7)(26/7)(30/7) 397.5 (18/1)(20/7)(22/7)	08 CD	3	3-1/4	5/8	7-5/8	3/8	2	0.60
AL-80-4A	2				3	3-1/4	5/8	7-5/8	5/16	3	0.65
AL-90-2B	1	450 477 500 550	397.5 (24/7)(26/7)(30/7) 477 (18/1)(20/7)(22/7)(24/7)	09 CD	3-1/2	3-1/4	5/8	8-1/4	1/2	2	0.80
AL-90-4A	2				4	3-1/4	5/8	9	3/8	3	0.90
AL-90-4B	2				4	4-1/4	1-1/8	10	3/8	4	1.00
AL-100-2B	1	556.5 600 636 650	477 (26/7)(30/7) 500 (30/7) 556.5 (18/1)(20/7) (22/7)(36/1) 556.5 (24/7)(26/7)(45/7) 605 (36/1)	10 CD	4	3-1/4	5/8	8-3/4	1/2	2	0.95
AL-100-4A	2				4	3-1/4	5/8	8-3/4	1/2	3	1.10
AL-100-4B	2				4	4-1/4	1-1/8	10-3/8	3/8	4	1.40
AL-110-2B	1	700 715 750 795 800	556.5 (30/7) 605 (24/7)(26/7) (30/7)(30/19) 636 (20/7)(22/7)(24/7) (26/7)(30/7)(30/19)(54/7) 666.6 (24/7)(26/7)(54/7) 715.5 (24/7)(54/7) 795 (36/1)	11 CD	4-1/4	3-1/4	5/8	9-3/8	5/8	2	1.25
AL-110-4A	2				4-1/4	3	5/8	9-1/8	1/2	3	1.30
AL-110-4B	2				4-1/4	4-1/4	1-1/8	10-3/8	3/8	4	1.50
AL-120-2B	1	874.5 900 927.2 954	715.5 (26/7)(30/9) 795 (20/7)(22/7) 795 (24/7)(26/7) (30/7)(30/19) 795 (42/7)(45/7)(54/7) 900 (45/7) 954 (36/1)	12 CD	4-1/2	3-1/4	5/8	9/58	1/2	3	1.50
AL-120-4A	2				4-1/2	3-1/4	5/8	9 5/8	1/2	3	1.55
AL-120-4B	2				4-1/2	4-1/4	1-1/8	10-5/8	1/2	4	1.90
AL-130-4A	2	1000 1033 1113	874.5 (54/7) 900 (54/7) 954 (20/7)(24/7)(42/7) (45/7)(48/7)(54/7) 1033.5 (36/1)(42/7)(45/7)	13 CD	4-3/4	3-1/4	5/8	9-7/8	5/8	3	2.00
AL-130-4B	2				4-3/4	4-1/4	1-1/8	10-7/8	5/8	4	2.25

Continued on next page

COMPRESSION CONNECTORS

TYPE AL CONTINUED

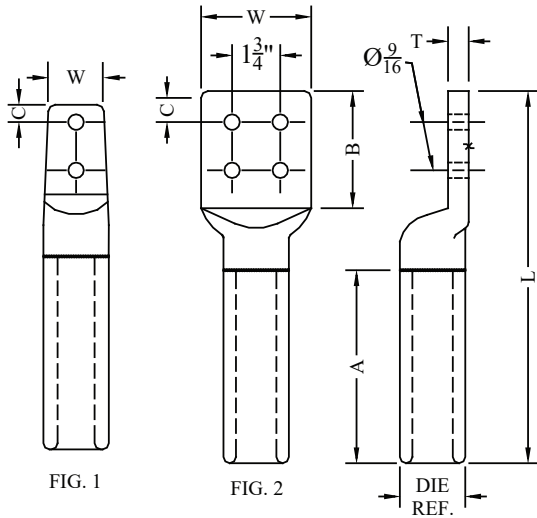
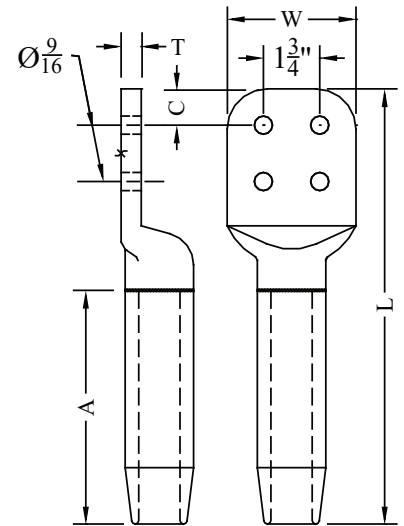

FIG. 1

FIG. 2

Type AL-EHV terminal used for high voltage applications where streamlined, tapered connectors are needed for corona free service. Add "EHV" to standard catalog number.
Example: AL-1031-4B-EHV



TYPE AL-EHV

CATALOG NUMBER	FIG. NO.	CONDUCTOR SIZE (MCM)		DIE REF	DIMENSION-INCHES						WEIGHT (POUNDS)
		AAC	ACSR		A	B	C	L	T	W	
AL-140-4A	2		954 (30/19)	14 CD	5	3	5/8	10-1/4	3/4	3	2.45
AL-140-4B	2	1192 1272	1033.5 (48/7)(54/7) 1113 (42/7)(45/7)(48/7) (54/19) 1192 (36/7)(42/7)(45/7) (48/7)		5	4-1/4	1-1/8	11-1/2	5/8	4	2.85
AL-150-4A	2		1192 (54/19)	15 CD	5	3-1/4	5/8	10-1/2	3/4	3	2.60
AL-150-4B	2	1351 1431 1510	1272 (42/7)(45/7)(48/7) (54/19) 1351 (42/7)(45/7)(54/19) 1431 (42/7)		5	4-1/4	1-1/8	11-1/2	3/4	4	3.15
AL-160-4A	2		1431 (45/7,54/19)	16 CD	5-1/2	3-1/4	5/8	11	3/4	4	3.05
AL-160-4B	2	1590 1700	1510 (45/7,54/19) 1590 (45/7)		5-1/2	4-1/4	1-1/8	12	3/4	4	3.55
AL-170-4B	2	1750 1800	1343 (72/7) 1590 (54/19) 1780 (84/19) 1864 (68/7)	17 CD	5-1/2	4-1/4	1-1/8	11-7/8	7/8	4	3.95
AL-180-4B	2	2000	2034 (72/7)	18 CD	6	4-1/4	1-1/8	12-3/4	1	4	5.00
AL-190-4B	2	2250 2300 2303.5	2156 (84/19) 2167 (72/7) 2306 (76/19) 2312 (76/19) 2332 (72/19)	19 CD	7-1/4	4-1/4	1-1/8	13-3/4	1	4	5.65

COMPRESSION CONNECTORS

TYPE ATCF

(Hex Die)
Compression Tee
Aluminum Cable to Flat

Pure aluminum compression tee for aluminum cable to flat NEMA pad.
Narrow conductor range assures a solid-mass cross-section after compression. Tees are for use with hex dies only and should not be used with circular dies. Contact sealant is factory applied to the barrel and the connector is sealed in a clear plastic bag.

Optional suffixes include the following:

- S: Short Barrel Design
- TTP: Ship with an AL/CU transition plate for pad
- WOI: Ship without oxide inhibitor in barrel
- MBFN: Include captive mounting bolts and flange nuts

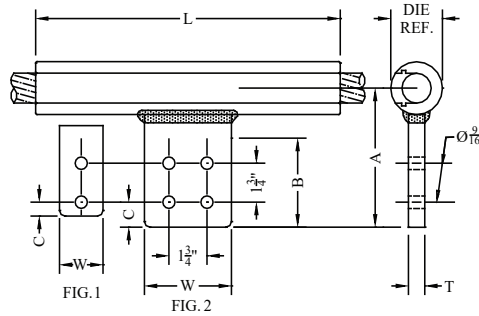

CATALOG NUMBER	FIG. NO.	CONDUCTOR SIZE (MCM)		DIE REF	DIMENSION-INCHES						WEIGHT (POUNDS)
		AAC	ACSR		A	B	C	L	T	W	
ATCF-528-2B	1	4/0 (7, 19)	-----	1.125 76AH 316	4-5/8	3	5/8	9	3/8	2	0.95
ATCF-528-4A	2				4-5/8	3	5/8	10	3/8	3	1.15
ATCF-563-2B	1	-----	4/0 (6/1)		4-5/8	3	5/8	9	3/8	2	0.95
ATCF-563-4A	2				4-5/8	3	5/8	10	3/8	3	1.15
ATCF-575-2B	1	250 (7)(19) (37)	-----		4-5/8	3	5/8	9	3/8	2	0.90
ATCF-575-4A	2				4-5/8	3	5/8	10	3/8	3	1.10
ATCF-593-2B	1	266.8 (7)(19)	-----		4-5/8	3	5/8	9	3/8	2	0.90
ATCF-593-4A	2				4-5/8	3	5/8	9	3/8	3	1.00
ATCF-609-2B	1	-----	266 (18/1)		4-9/16	3-1/4	5/8	9	3/8	2	0.90
ATCF-609-4A	2				4-9/16	3-1/4	5/8	10	3/8	3	1.10
ATCF-633-2B	1	300 (19)(37) (61)	266 (6/7)(22/7) (24/7)		4-9/16	3-1/4	5/8	9	3/8	2	0.85
ATCF-633-4A	2				4-9/16	3-1/4	5/8	10	3/8	3	1.00
ATCF-646-2B	1	-----	266 (26/7) 300 (18/1)		4-5/8	3	5/8	9	3/8	2	0.85
ATCF-646-4A	2				4-9/16	3-1/4	5/8	10-1/2	3/8	3	1.10
ATCF-677-2B	1	336.4 (19) (37)	266 (36/7) 336 (36/1)		4-9/16	3-1/4	5/8	10-1/2	3/8	2	0.90
ATCF-677-4A	2				4-5/8	3	5/8	10-1/2	3/8	3	1.05
ATCF-684-2B	1	350 (19)(37) (61)	300 (26/7) 336.4 (18/1) (20/7)		4-9/16	3-1/4	5/8	10-5/8	3/8	2	1.30
ATCF-684-4A	2				4-9/16	3-1/4	5/8	10-5/8	3/8	3	1.40
ATCF-724-2B	1	397.5 (19)	300 (30/7) 336.4 (22/7) (24/7)(26/7)		4-11/16	3-1/4	5/8	10-3/4	1/2	2	1.25
ATCF-724-4A	2				4-1/2	3-1/4	5/8	10-3/4	1/2	3	1.35
ATCF-736-2B	1	400 (19)(37)	397.5 (36/1)		4-11/16	3-1/4	5/8	10-3/4	1/2	2	1.35
ATCF-736-4A	2				4-7/8	3-1/4	5/8	11-1/2	5/8	3	1.70
ATCF-743-2B	1	-----	336.4 (30/7) 397 (18/1)		4-11/16	3-1/4	5/8	10-3/4	1/2	2	1.30
ATCF-743-4A	2				4-9/16	3-1/4	5/8	10-5/8	3/8	3	1.35
ATCF-783-2B	1	450 (37)	397 (24/7)(26/7)	4-7/8	3-1/4	5/8	10	1/2	2	1.60	
ATCF-783-4A	2			4-5/8	3	5/8	11	3/8	3	2.15	
ATCF-795-2B	1	477 (19)(37)	-----	4-11/16	3-1/4	5/8	10-3/4	1/2	2	1.25	
ATCF-795-4A	2			4-9/16	3-1/4	5/8	11	3/8	3	1.30	
ATCF-814-2B	1	500 (19)(37)	397.5 (30/7) 477 (18/1)(36/1)	4-11/16	3-1/4	5/8	10-3/4	1/2	2	1.20	
ATCF-814-4A	2			4-11/16	3-1/4	5/8	11-3/4	3/8	3	1.25	

COMPRESSION CONNECTORS

TYPE ATCF CONTINUED

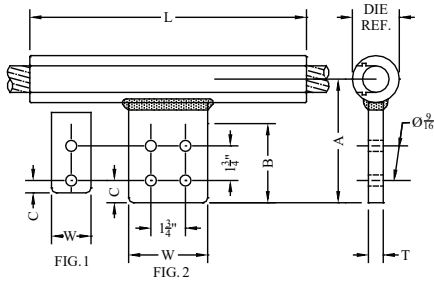

Type ATCF-EHV compression tee to flat. Used for EHV applications where streamlined, tapered connector are needed for corona free service. Add "EHV" to standard catalog number. EX: ATCF-1031-4B-EHV

TYPE ATCF-EHV

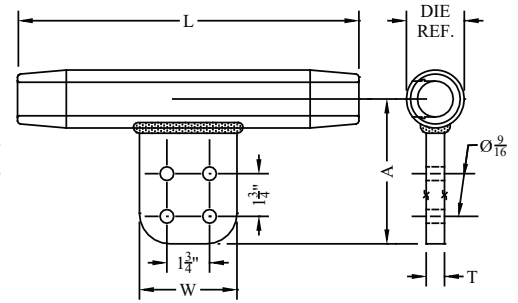

CATALOG NUMBER	FIG. NO.	CONDUCTOR SIZE (MCM)		DIE REF	DIMENSION-INCHES						WEIGHT (POUNDS)
		AAC	ACSR		A	B	C	L	T	W	
ATCF-846-2B	1	-----	477 (20/7)	1.312 20AH 317	4-13/16	3-1/4	5/8	10-5/8	5/8	2	1.25
ATCF-846-4A	2		(22/7)(24/7)		4-7/8	3-1/4	5/8	12	1/2	3	1.45
ATCF-858-2B	1	556.5 (19)(37)	477 (26/7)	1.312 20AH 317	4-11/16	3-1/4	5/8	10-3/4	1/2	2	1.15
ATCF-858-4A	2		4-3/4		3-1/4	5/8	10-3/4	1/2	3	1.35	
ATCF-883-2B	1	-----	477 (30/7)	1.500 24AH 261	4-7/8	3	5/8	12	5/8	2	1.80
ATCF-883-4A	2		556.5 (18/1)(36/1)		4-7/8	3-1/4	5/8	12	5/8	3	2.00
ATCF-893-2B	1	600 (37)(61)	-----	1.500 24AH 261	4-7/8	3-1/4	5/8	11	5/8	2	1.80
ATCF-893-4A	2		4-7/8		3-1/4	5/8	12	5/8	3	2.00	
ATCF-918-2B	1	636 (37)(61)	500 (30/7)	1.500 24AH 261	4-7/8	3-1/4	5/8	11-1/2	1/2	2	1.60
ATCF-918-4A	2		556.5 (22/7)(4/7) 605 (36/1)		4-7/8	3-1/4	5/8	12	5/8	3	1.95
ATCF-940-2B	1	650 (37)(61)(91)	556 (26/7)	1.500 24AH 261	4-7/8	3-1/4	5/8	11-1/2	1/2	2	1.55
ATCF-940-4A	2		636 (18/1)(36/1)		4-7/8	3-1/4	5/8	11-1/2	1/2	3	1.75
ATCF-966-2B	1	700 (37)(61)(91)	556.5 (30/7)	1.500 24AH 261	4-1/2	3-1/4	5/8	10	1/2	2	1.35
ATCF-966-4A	2		605 (24/7)(26/7) 666.5 (36/1)		4-7/8	3-1/4	5/8	12	1/2	3	1.85
ATCF-987-2B	1	715 (37)(61)	636 (24/7)(54/7)	1.500 24AH 261	4-7/8	3-1/4	5/8	11	1/2	2	1.55
ATCF-987-4A	2		715 (36/1)		4-7/8	3-1/4	5/8	12	1/2	3	1.70
ATCF-1000-2B	1	750 (37)(61)	605 (30/7)(30/19)	1.500 24AH 261	4-7/8	3-1/4	5/8	11-1/2	1/2	2	1.45
ATCF-1000-4A	2		636 (26/7)(30/7) 666.6 (24/7)(54/7)		4-7/8	3-1/4	5/8	12	1/2	3	1.80
ATCF-1031-2B	1	795 (37)(61) 800 (61)(91)	636 (30/19)	1.843 30AH 292	4-7/8	3-1/4	5/8	12	5/8	2	2.55
ATCF-1031-4A	2		666.6 (26/7)		4-7/8	3-1/4	5/8	12	5/8	3	2.80
ATCF-1040-2B	1	-----	715 (24/7)(54/7)	1.843 30AH 292	4-7/8	3-1/4	5/8	12	5/8	2	2.55
ATCF-1040-4A	2		795 (36/1)		4-7/8	3-1/4	5/8	12	5/8	3	2.75
ATCF-1063-4A	2	-----	715.5 (26/7)	1.843 30AH 292	4-7/8	3-1/4	5/8	12	5/8	3	2.75
ATCF-1063-4B	2		795 (20/7)(42/7)(45/7)		6	4-1/4	1-1/8	14	5/8	4	3.55
ATCF-1094-4A	2	874 (37)(61) 900 (37)(61)(91)	715 (30/19)	1.843 30AH 292	5	3-1/4	5/8	13	5/8	3	2.85
ATCF-1094-4B	2		795 (24/7)(54/7)		5-7/8	4-1/4	1-1/8	14	5/8	4	3.50
ATCF-1108-4A	2	-----	795 (26/7)	1.843 30AH 292	5	3-1/4	5/8	14	5/8	3	2.95
ATCF-1108-4B	2		795 (26/7)		5-7/8	4-1/4	1-1/8	14	5/8	4	3.45
ATCF-1126-4A	2	954 (37)(61)	795 (30/19)	1.843 30AH 292	5	3-1/4	5/8	14	5/8	3	2.90
ATCF-1126-4B	2		795 (30/19)		6	4-1/4	1-1/8	14	5/8	4	3.40
ATCF-1152-4A	2	1000 (37)(61)	874 (54/7)	1.843 30AH 292	4-7/8	3-1/4	5/8	14	5/8	3	2.85
ATCF-1152-4B	2		900 (45/7) 954 (36/1)		6	4-1/4	1-1/8	14	5/8	4	3.30

COMPRESSION CONNECTORS

TYPE ATCF CONTINUED

CATALOG NUMBER	FIG. NO.	CONDUCTOR RANGE		DIE REF.	DIMENSIONS - INCHES						WEIGHT (POUNDS)
		AAC	ACSR		A	B	C	L	T	W	
ATCF-1172-4A	2	1033.5 (37)(61)	900 (54/7)	2.125 34AH 575	5-1/16	3-1/4	5/8	14	3/4	3	3.55
ATCF-1172-4B	2		954 (45/7)		6	4-1/4	1-1/8	14	5/8	4	4.50
ATCF-1186-4A	2	-----	954 (20/7)(48/7)		5-1/16	3-1/4	5/8	14	5/8	3	3.90
ATCF-1186-4B	2		1033 (36/1)		5-3/4	4	1-1/8	14	5/8	4	4.35
ATCF-1196-4A	2	-----	954 (24/7)(54/7)		5-1/16	3-1/4	5/8	14	5/8	3	3.90
ATCF-1196-4B	2				5-3/4	4	1-1/8	14	5/8	4	4.35
ATCF-1216-4A	2	1113 (61) 1100 (91)	1033.5 (42/7)(45/7)		5-1/16	3-1/4	5/8	14	5/8	3	3.90
ATCF-1216-4B	2				6-1/8	4-1/4	1-1/8	14	3/4	4	4.60
ATCF-1246-4A	2	-----	954 (30/19)		5-1/16	3-1/4	5/8	14	5/8	3	3.80
ATCF-1246-4B	2		1033.5 (54/7) 1113 (42/7)		6-1/8	4-1/4	1-1/8	14	3/4	4	4.50
ATCF-1264-4A	2	1192.5 (61) 1200 (91)	1113 (48/7)(45/7)		5-1/16	3-1/4	5/8	14	5/8	3	3.75
ATCF-1264-4B	2				6-1/8	4-1/4	1-1/8	14	3/4	4	4.45
ATCF-1293-4A	2	1250 (91)	1113 (54/19)		5-1/4	3-1/4	5/8	14	3/4	3	5.00
ATCF-1293-4B	2		1192.5 (36/7)(42/7)		6-3/16	4-1/4	1-1/8	14	3/4	4	5.60
ATCF-1302-4A	2	1272	1192.5 (45/7)(48/7)		5-1/4	3-1/4	5/8	14	3/4	3	4.95
ATCF-1302-4B	2		1272 (36/1)		6-1/4	4-1/4	1-1/8	14	3/4	4	5.55
ATCF-1345-4A	2	1351 (61)	1192.5 (54/19)	5-1/4	3-1/4	5/8	14	3/4	3	4.85	
ATCF-1345-4B	2		1272 (42/7)(45/7)	6-1/4	4-1/4	1-1/8	14	3/4	4	5.45	
ATCF-1385-4A	2	1431 (61)	1272 (48/7)(54/19)	5-1/4	3-1/4	5/8	14	3/4	3	4.75	
ATCF-1385-4B	2		1351.5 (42/7)(45/7)	6-1/4	4-1/4	1-1/8	14	3/4	4	5.85	
ATCF-1417-4A	2	1500 1510.5 (61)	1431 (42/7)	5-1/4	3-1/4	5/8	14	5/8	3	5.50	
ATCF-1417-4B	2			6-1/4	4-1/4	1-1/8	15	3/4	4	5.50	
ATCF-1427-4A	2	-----	1351.5 (54/19)	5-1/4	3-1/4	5/8	14	3/4	3	4.60	
ATCF-1427-4B	2		1431 (45/7)(48/7)	6-1/4	4-1/4	1-1/8	14	3/4	4	5.15	
ATCF-1466-4A	2	1590 (61)(91) 1600 (127)(169)	1431 (54/19)	5-1/4	3-1/4	5/8	14	3/4	3	4.50	
ATCF-1466-4B	2		1510 (45/7)	6-1/4	4-1/4	1-1/8	15	3/4	4	5.35	
ATCF-1506-4A	2	1700 (127)(169)	1510 (54/19)	5-1/4	3-1/4	5/8	14	3/4	3	4.40	
ATCF-1506-4B	2		1590 (45/7)	6-1/4	4-1/4	1-1/8	15	3/4	4	5.20	
ATCF-1526-4A	2	1750	-----	5-1/4	3-1/4	5/8	14	3/4	3	4.20	
ATCF-1526-4B	2		6-1/4	4-1/4	1-1/8	15	3/4	4	5.10		
ATCF-1548-4B	2	1800 (127)	1590 (54/19)	6-1/4	4-1/4	1-1/8	15	3/4	4	5.00	
ATCF-1632-4B	2	2000 (91)(127)	-----	6-1/4	4-1/4	1-1/8	15	3/4	4	4.70	
ATCF-1737-4B	2	2250 (61)(91)	2167 (72/7)	6-1/4	4-1/4	1-1/8	15	3/4	4	7.70	
ATCF-1762-4B	2	2300/2303.5	2156 (84/19)	6-1/4	4-1/4	1-1/8	15	3/4	4	7.60	
ATCF-1802-4B	2	-----	2306/2312 (76/19)	6-1/2	4-1/4	1-1/8	18	3/4	4	8.65	
ATCF-1824-4B	2	2500 (91)(127)	2300 (84/19)	6-1/2	4-1/4	1-1/8	15	3/4	4	8.50	
ATCF-1880-4B	2	-----	2515 (76/19)	6-1/2	4-1/4	1-1/8	18	3/4	4	8.25	
ATCF-1998-4B	2	3000 (127)(169)	-----	6-1/2	4-1/4	1-1/8	18	3/4	4	7.65	
ATCF-2158-4B	2	3500 (127)(169)	-----	6-1/2	4-1/4	1-1/8	18	3/4	4	6.55	
ATCF-2250-4B	2	3640	-----	6-1/4	4-1/4	1-1/8	18	3/4	4	6.45	
ATCF-2283-4B	2	4000	3364 (108/37)	CONTACT FACTORY FOR DETAILS							
ATCF-2400-4B	2	4327	-----								

COMPRESSION CONNECTORS

TYPE ATCF

Circular Die
Compression Tee
Aluminum Cable to Flat

Pure aluminum compression tee for aluminum cable to flat NEMA pad.
Tees are for use with circular dies only and should not be used with hex dies.
Contact sealant is factory applied to the barrel and the connector is sealed in a clear plastic bag.

Optional suffixes include the following:

- S: Short Barrel Design
- TTP: Ship with an AL/CU transition plate for pad
- WOI: Ship without oxide inhibitor in barrel
- MBFN: Include captive mounting bolts and flange nuts

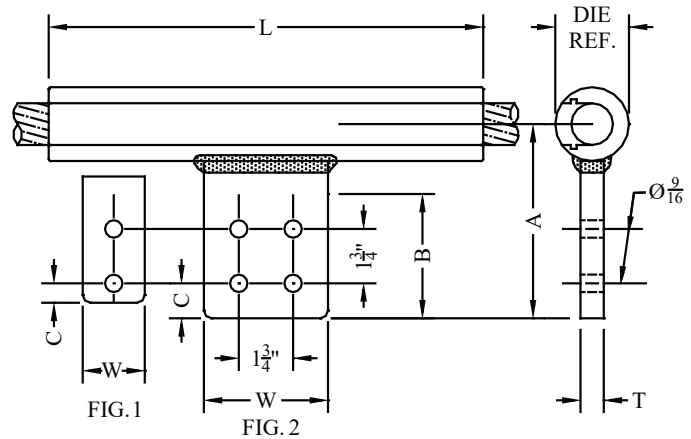

CATALOG NUMBER	FIG. NO.	CONDUCTOR SIZE (MCM)		DIE REF	DIMENSION-INCHES						WEIGHT (POUNDS)
		AAC	ACSR		A	B	C	L	T	W	
ATCF-70-2B	1	300	266.8 (18/1)(22/7)(24/7)	07 CD	4-9/16	3-1/4	5/8	9-5/8	3/8	2	0.75
ATCF-70-4A	2	336.4 350	(26/7)(30/7) 300 (26/7)		4-9/16	3-1/4	5/8	11	3/8	3	0.95
ATCF-80-2B	1	397.5 400	336.4 (18/7)(20/7)	08 CD	4-5/8	3-1/4	5/8	9-5/8	3/8	2	0.90
ATCF-80-4A	2		(24/7)(26/7)(30/7) 397.5 (18/1)(20/7)(22/7)		4-5/8	3-1/4	5/8	10-5/8	3/8	3	1.10
ATCF-90-2B	1	450 477 500 550	336.4 (30/7)	09 CD	4-1/2	3-1/4	5/8	9	3/8	2	1.00
ATCF-90-4A	2		397.5 (24/7,26/7,30/7)		4-7/8	3-1/4	5/8	10-3/4	3/8	3	1.25
ATCF-90-4B	2		477 (36/1,18/1,24/7)		5-11/16	4	1-1/8	12	3/8	4	1.65
ATCF-100-2B	1	556.5 600 636 650	477 (26/7)(30/7)	10 CD	4-3/4	3-1/4	5/8	10	1/2	2	1.35
ATCF-100-4A	2		500(30/7)		4-3/4	3	5/8	11	1/2	3	1.60
ATCF-100-4B	2		556.5 (18/1)(20/7)(22/7) (36/1) 556.5 (24/7)(26/7) (45/7) 605 (36/1)		5-7/8	4-1/4	1-1/8	12-1/2	1/2	4	2.20
ATCF-110-2B	1	700 715 750 795 800	556.5 (30/7)	11 CD	5	3-1/4	5/8	11-1/2	5/8	2	1.35
ATCF-110-4A	2		605 (24/7)(26/7)(30/7) (30/19)		5-1/16	4-1/4	5/8	12-1/2	5/8	3	2.00
ATCF-110-4B	2		636 (20/7)(22/7)(24/7) (26/7)(30/7)(30/19) (54/7) 666.6 (24/7)(26/7) (54/7) 715.5 (24/7)(54/7) 795 (36/1)		5-13/16	4-1/2	1-1/8	12-1/2	5/8	4	2.60
ATCF-120-4A	2	874.5 900 927.2 954	715.5 (26/7)	12 CD	5	3	5/8	11-1/2	1/2	3	2.15
ATCF-120-4B	2		795 (20/7,22/7) 795 (24/7,26/7) 795 (45/7,54/7) 900 (45/7) 954 (36/1)		6	4-1/4	1-1/8	12-1/2	5/8	4	2.90

COMPRESSION CONNECTORS

TYPE ATCF CONTINUED

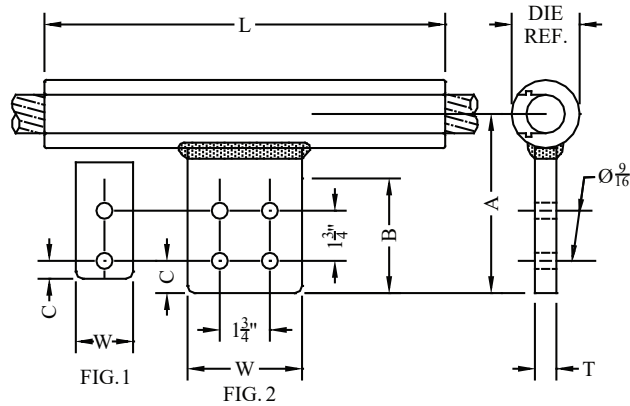

TYPE ATCF-EHV

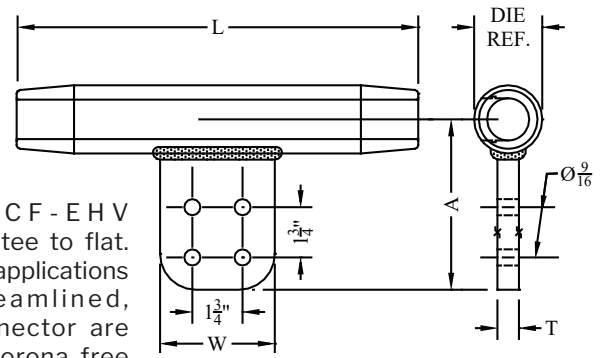

Type ATCF-EHV compression tee to flat. Used for EHV applications where streamlined, tapered connector are needed for corona free service. Add "EHV" to standard catalog number.
EX: ATCF-1031-4B-EHV

CATALOG NUMBER	FIG. NO.	CONDUCTOR SIZE (MCM)		DIE REF	DIMENSION-INCHES						WEIGHT (POUNDS)
		AAC	ACSR		A	B	C	L	T	W	
ATCF-130-4A	2		874.5 (54/7) 900 (54/7)	13 CD	5	3	5/8	13	5/8	3	3.15
ATCF-130-4B	2	1000 1033 1113	954 (20/7)(24/7) (42/7)(48/7)(45/7) (54/7) 1033.5 (36/1) (42/7)(45/7)		6	4-1/4	1-1/8	14	1/2	4	3.80
ATCF-140-4A	2		954 (30/19) 1033.5 (48/7) (54/7)		14 CD	5-1/4	3	5/8	14	5/8	3
ATCF-140-4B	2	1192 1250 1272	1113 (42/7)(45/7) (48/7)(54/19) 1192 (36/7)(42/7) (45/7)(48/7)	5-13/16		3-1/4	1-1/8	15	1/2	4	4.00
ATCF-150-4A	2		1192 (54/19) 1272 (42/7)(45/7) (48/7)(54/19)	15 CD		5-1/8	3	5/8	13-3/4	3/4	3
ATCF-150-4B	2	1351 1431 1510	1351.5 (42/7) (45/7)(54/19) 1431 (42/7)		6-1/8	4	1-1/8	14-3/4	3/4	4	4.60
ATCF-160-4A	2		1431 (45/7)(48/7) (54/19)		16 CD	4-7/8	3-1/2	5/8	13	3/4	3
ATCF-160-4B	2	1590 1700	1510.5 (45/7) (54/19) 1590 (42/7)(45/7)	5-7/8		4-1/4	1-1/8	15	3/4	4	5.20
ATCF-170-4B	2	1750 1800	1590 (54/19) 1780 (84/19) 1843 (72/7) 1864 (68/7)	17 CD		6-1/4	4-1/4	1-1/8	15	3/4	4
ATCF-180-4B	2	2000	2034 (72/7)	18 CD	6-1/4	4-1/4	1-1/8	15	3/4	4	5.50
ATCF-190-4B	2	2250 2300 2303.5	2167 (72/7) 2306 (76/19) 2312 (76/19) 2332 (72/19)	19 CD	6-1/4	4-1/4	1-1/8	15	3/4	4	6.85

COMPRESSION CONNECTORS

TYPE CL

Compression Terminal
Copper Cable to Flat Pad

Pure copper compression terminal for copper cable to flat NEMA pad.
Contact sealant is factory applied in the barrel and the connector is sealed in a clear plastic bag.

Optional suffixes include the following:

- S: Short Barrel Design
- TTP: Ship with an AL/CU transition plate for pad
- WOI: Ship without oxide inhibitor in barrel
- MBFN: Include captive mounting bolts and flange nuts

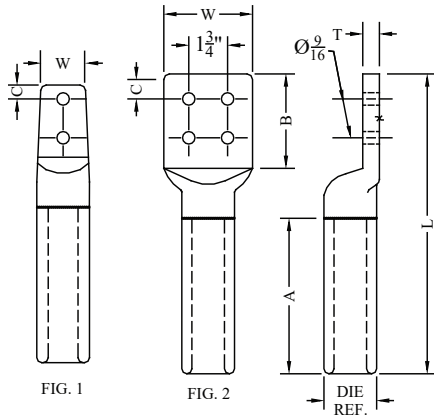
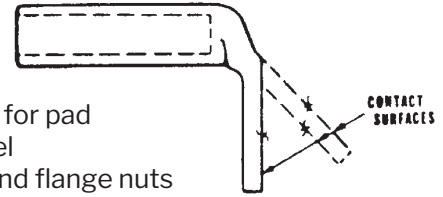

Angle connector may be obtained by adding desired angle to catalog number.
Example: CL-20-2B-15

Two cable to flat connection is also available. These are two compressions forming to a single 4 hole NEMA pad. See illustrations on pages 273 and 290.
Example: CL2-677-4A

CATALOG NUMBER	FIG. NO.	COPPER CONDUCTOR	DIE REF.	DIMENSION - INCHES						WEIGHT (POUNDS)	
				A	B	C	L	T	W		
CL-04-2A	1	#4 STR	.640 73AH 243	2	3-1/4	5/8	6-1/8	1/4	1-1/4	0.55	
CL-06-2A	1	#2 STR		2	3-1/4	5/8	6-1/8	1/4	1-1/4	0.55	
CL-08-2A	1	1/0 STR		3	3-1/4	5/8	7-1/8	1/4	1-1/4	0.60	
CL-09-2A	1	2/0 STR	.840 74AH 249	3	3-1/8	5/8	7-1/4	5/16	1-1/2	1.05	
CL-09-4A	2			3	3-1/8	5/8	7-1/4	1/4	3	1.30	
CL-10-2A	1	3/0 STR		3	3-1/4	5/8	7-1/2	3/8	1-1/2	1.10	
CL-10-4A	2			3	3-1/8	5/8	7-1/4	1/4	3	1.25	
CL-11-2A	1	4/0 STR		3	3-1/8	5/8	7-1/4	5/16	1-1/2	0.95	
CL-11-4A	2			3	3-1/8	5/8	7-1/4	1/4	3	1.20	
CL-12-2A	1	250 MCM		3	3-1/8	5/8	7-1/4	3/8	1-1/2	1.00	
CL-12-4A	2			3	3-1/2	5/8	7-5/8	1/4	3	1.15	
CL-14-2A	1	300 MCM		1.000 75AH 251	3	3-1/4	5/8	7-3/8	3/8	1-1/2	1.25
CL-14-4A	2				3	3-1/4	5/8	7-3/8	1/4	3	1.45
CL-16-2A	1	350 MCM	3		3-1/4	5/8	7-3/8	3/8	1-1/2	1.20	
CL-16-4A	2		3		3-1/4	5/8	7-3/8	5/16	3	1.55	
CL-17-2B	1	400 MCM	1.125 76AH 316		4	3-1/4	5/8	8-1/2	3/8	1-3/4	1.75
CL-17-4A	2				4	3-1/4	5/8	8-1/2	5/16	3	2.00
CL-19-2B	1	450 MCM			4	3-1/4	5/8	8-1/2	3/8	1-3/4	1.65
CL-19-4A	2				4	3-1/4	5/8	8-1/2	5/16	3	1.90
CL-20-2B	1	500 MCM			4	3-1/4	5/8	8-1/2	3/8	1-3/4	1.60
CL-20-4A	2				4	3-1/4	5/8	8-1/2	5/16	3	1.85
CL-22-2B	1	600 MCM		1.312 20AH 317	5	3-1/4	5/8	9-1/2	1/2	2	2.60
CL-22-4A	2				5	3-1/4	5/8	9-1/2	3/8	3	2.70

Continued on next page

SEFCOR

Return To Index

COMPRESSION CONNECTORS

TYPE CL CONTINUED

For 2" x 3" pad, substitute 2B in catalog number.

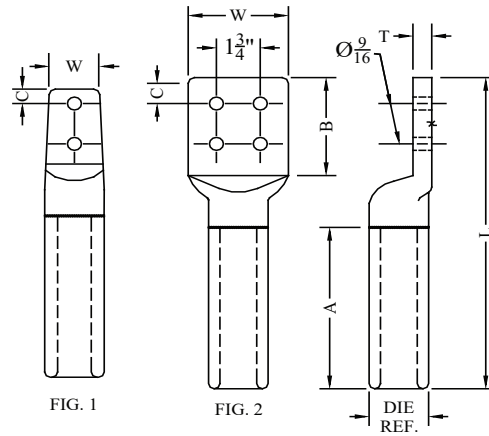

CATALOG NUMBER	FIG. NO.	COPPER CONDUCTOR	DIE REF.	DIMENSION - INCHES						WEIGHT (POUNDS)	
				A	B	C	L	T	W		
CL-23-4A	2	650 MCM	1.312 20AH 317	4	3-1/4	5/8	8-5/8	3/8	3	2.45	
CL-23-4B	2			4	4-1/4	1-1/8	9-5/8	3/8	4	3.35	
CL-25-4A	2	700 MCM		4-1/4	3-1/4	5/8	8-5/8	3/8	3	2.35	
CL-25-4B	2			4-1/4	3-1/4	1-1/8	11-1/8	3/8	4	2.65	
CL-27-4A	2	750 MCM		4-1/4	3-1/4	5/8	8-5/8	3/8	3	2.25	
CL-27-4B	2			5-1/2	4-1/4	1-1/8	11-1/8	3/8	4	3.45	
CL-28-4A	2	800 MCM	1.500 24AH 261	4-1/2	3-1/4	5/8	9-1/8	3/8	3	3.15	
CL-28-4B	2			5-1/2	4-1/4	1-1/8	11-1/8	3/8	4	3.25	
CL-30-4A	2	850 MCM		4-1/2	3-1/4	5/8	9-1/8	3/8	3	3.05	
CL-30-4B	2			4-1/2	4-1/4	1-1/8	11-1/8	3/8	4	3.95	
CL-32-4A	2	900 MCM		4-1/4	3-1/4	5/8	8-7/8	3/8	3	2.90	
CL-32-4B	2			5-1/2	4-1/4	1-1/8	11-1/8	3/8	4	4.10	
CL-33-4A	2	950 MCM		5-1/2	3-1/4	5/8	10-1/8	3/8	3	3.85	
CL-33-4B	2			5-1/2	4-1/4	1-1/8	11-1/8	3/8	4	4.00	
CL-34-4A	2	1000 MCM		4-1/2	3-1/4	5/8	9-1/8	3/8	3	2.80	
CL-34-4B	2			5-1/2	4-1/4	1-1/8	11-1/8	3/8	4	3.60	
CL-38-4A	2	1250 MCM		1.843 30AH 292	5-1/2	3-1/4	5/8	11	1/2	3	5.65
CL-38-4B	2				5-1/2	4-1/4	1-1/8	11-1/4	1/2	4	6.15
CL-42-4A	2	1500 MCM	2.125 34AH 575	7-1/4	3-1/4	5/8	12-1/2	3/4	3	8.85	
CL-42-4B	2			7	4-1/4	1-1/8	13-1/4	5/8	4	9.80	
CL-45-4A	2	1750 MCM		7-1/4	3-1/4	5/8	12-3/4	3/4	3	8.20	
CL-45-4B	2			7-1/4	4-1/4	1-1/8	14	1/2	4	9.25	
CL-48-4A	2	2000 MCM	2.375 38AH 478 728	7-1/4	3-1/4	5/8	13	3/4	3	10.90	
CL-48-4B	2			7-1/4	4-1/4	1-1/8	14	3/4	4	12.65	

COMPRESSION CONNECTORS

TYPE CTCF

Compression Tee
Copper Cable to Flat

A pure copper compression tee for a continuous cable run to flat NEMA pad. Narrow conductor range assures a solid-mass cross-section after compression. Contact sealant is factory-applied to the barrel and connector is sealed in a clear plastic bag.

Optional suffixes include the following:

- S: Short Barrel Design
 - TTP: Ship with an AL/CU transition plate for pad
 - WOI: Ship without oxide inhibitor in barrel
 - MBFN: Include captive mounting bolts and flange nuts
- For 2"x 3" Pad, substitute -2B for -2A, in catalog number.
For 4"x 4" Pad substitute -4B.
- Contact Factory for sizes not listed.

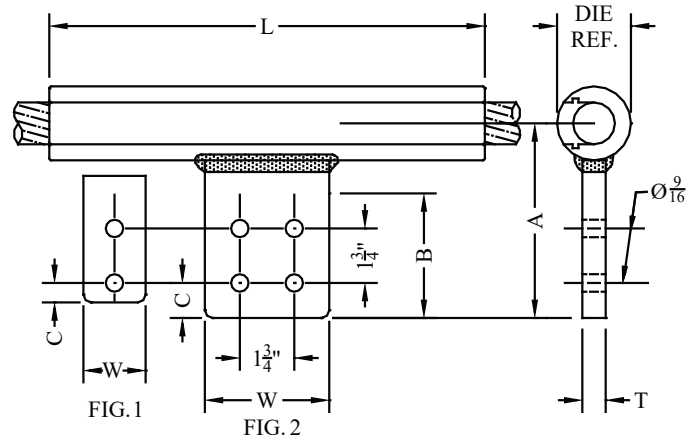

CATALOG NUMBER	FIG. NO.	COPPER CONDUCTOR	DIE REF.	DIMENSION - INCHES						WEIGHT (POUNDS)
				A	B	C	L	T	W	
CTCF-08-2A	1	1/0 STR	.840 74AH 249	4-7/16	3-1/4	5/8	8	1/4	1-1/2	1.55
CTCF-09-2A	1	2/0 STR		4	3	5/8	8	1/4	1-1/2	1.50
CTCF-09-4A	2			4	3	5/8	8	1/4	3	1.95
CTCF-10-2A	1	3/0 STR		4	3	5/8	8	1/4	1-1/2	1.40
CTCF-10-4A	2			4	3	5/8	9	1/4	3	1.80
CTCF-11-2A	1	4/0 STR		4	3	5/8	8	1/4	1-1/2	1.30
CTCF-11-4A	2			4-1/2	3-1/8	5/8	9	1/4	3	1.85
CTCF-12-2A	1	250 MCM		4	3	5/8	8-1/2	1/4	1-1/2	1.20
CTCF-12-4A	2			4	3	5/8	9	1/4	3	2.25
CTCF-14-2A	1	300 MCM		4-7/16	3-1/8	5/8	9	1/4	1-1/2	2.60
CTCF-14-4A	2		4	3	5/8	9	1/4	3	2.10	
CTCF-16-2A	1	350 MCM	4-3/16	3-1/8	5/8	9	1/4	1-1/2	2.10	
CTCF-16-4A	2		4-1/2	3	5/8	10	1/4	3	2.80	
CTCF-17-2A	1	400 MCM	4-1/2	3-1/8	5/8	9	3/8	1-1/2	2.50	
CTCF-17-4A	2		4-1/2	3-1/8	5/8	10	3/8	3	4.15	
CTCF-19-2A	1	450 MCM	4-1/2	3-1/8	5/8	9	3/8	1-1/2	2.70	
CTCF-19-4A	2		4-1/2	3-1/8	5/8	10	3/8	3	2.70	
CTCF-20-2B	1	500 MCM	3-3/4	3-1/8	5/8	10	3/8	2	3.60	
CTCF-20-4A	2		4-1/2	3-1/8	5/8	10	3/8	3	3.80	
CTCF-20-4B	2		5-1/2	4-1/4	1-1/8	11	3/8	4	5.00	
CTCF-22-2B	1	600 MCM	5	3-1/8	5/8	10	3/8	2	3.90	
CTCF-22-4A	2		4-3/4	3-1/4	5/8	11	3/8	3	3.40	
CTCF-22-4B	2		5	4-1/4	1-1/8	11	3/8	4	4.10	

COMPRESSION CONNECTORS

TYPE CTCF CONTINUED

CATALOG NUMBER	FIG. NO.	COPPER CONDUCTOR	DIE REF.	DIMENSION - INCHES						WEIGHT (POUNDS)	
				A	B	C	L	T	W		
CTCF-23-4A	2	650 MCM	1.312 20AH 317	5	3-1/8	5/8	11	3/8	3	3.70	
CTCF-23-4B	2			5	4-1/4	1-1/8	11	3/8	4	3.70	
CTCF-25-4A	2	700 MCM		5-1/4	3-1/8	5/8	11	3/8	3	3.90	
CTCF-25-4B	2			5-1/4	4-1/4	1-1/8	12	3/8	4	3.90	
CTCF-27-4A	2	750 MCM	1.500 24AH 261	4-3/4	3-1/4	5/8	11	3/8	3	4.80	
CTCF-27-4B	2			5-1/2	4-1/4	1-1/8	12	3/8	4	5.50	
CTCF-28-4A	2	800 MCM		5-1/2	3-1/8	5/8	12	3/8	3	5.10	
CTCF-28-4B	2			5-1/2	4-1/4	1-1/8	12	3/8	4	5.50	
CTCF-30-4A	2	850 MCM		5-1/2	3-1/8	5/8	12	3/8	3	5.50	
CTCF-30-4B	2			5-1/2	4-1/4	1-1/8	13	3/8	4	5.50	
CTCF-32-4A	2	900 MCM		4-3/4	3-1/4	5/8	11	3/8	3	5.50	
CTCF-32-4B	2			5-1/2	4-1/4	1-1/8	13	3/8	4	5.70	
CTCF-33-4A	2	950 MCM	5-1/2	3-1/8	5/8	13	1/2	3	5.70		
CTCF-33-4B	2		5-1/2	4-1/4	1-1/8	14	3/8	4	5.70		
CTCF-34-4A	2	1000 MCM	1.843 30AH 292	5	3-1/8	5/8	12	1/2	3	5.00	
CTCF-34-4B	2			6	4-1/8	1-1/8	13	3/8	4	5.50	
CTCF-38-4A	2	1250 MCM		5-1/2	3-1/4	5/8	13	1/2	3	7.00	
CTCF-38-4B	2			5-1/2	4-1/8	1-1/8	14	3/8	4	7.50	
CTCF-42-4A	2	1500 MCM		7-1/4	3-1/8	5/8	13	5/8	3	12.40	
CTCF-42-4B	2			6-1/16	4-1/4	1-1/8	13	3/4	4	13.20	
CTCF-45-4A	2	1750 MCM		2.125 34AH 575	7-1/4	3-1/8	5/8	13	1/2	3	15.10
CTCF-45-4B	2				7-1/4	4-1/8	1-1/8	14	5/8	4	15.50
CTCF-48-4A	2	2000 MCM	7-1/4		3-1/8	5/8	13	3/4	3	17.10	
CTCF-48-4B	2		7-1/4		4-1/8	1-1/8	14	3/4	4	18.00	

COMPRESSION CONNECTORS

QCT-HV



“QCT-HV” is an aluminum compression terminal used for EHV applications. Cable to 4x4 pad with bolt shield installed for corona free service.

AL2



“AL2” is an aluminum compression terminal used to attach two (2) conductors to a single 4-hole terminal pad. Add -EHV for use on EHV applications.

ATCC



“ATCC” is an aluminum compression tee cable to cable for use on standard voltage applications. Add -EHV for corona-free service on EHV applications. Open-run to tap.

ARS



“ARS” is an open-run aluminum cable repair sleeve.

AS



“AS” is a closed-run aluminum jumper sleeve for jumping two like or unlike sizes of cable.

CTCC



“CTCC” is a copper compression tee cable to cable for use on standard voltage applications. Add -EHV for corona-free service on EHV applications. Open-run to tap.

CS

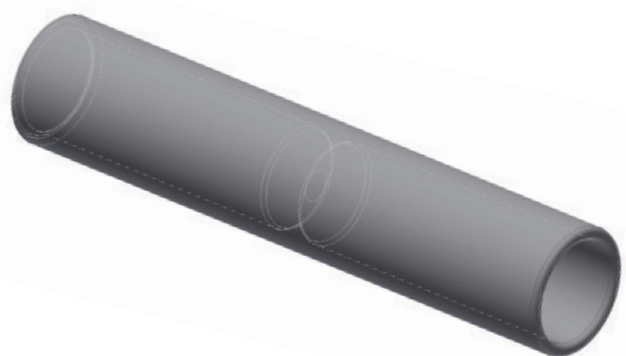

“CS” is a closed-run copper jumper sleeve for joining two like or unlike sizes of cable.

***NOTE: Types ARS, AS & CS are NOT for full tension application**

***CONTACT FACTORY FOR DETAILS**

STRAIN HARDWARE



AQD



ASDE



FQD



BCSS



BCS

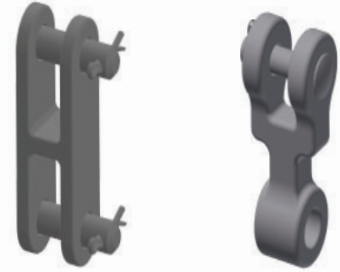

CLEVIS-CLEVIS CLEVIS-EYE



SOCKET-EYE SOCKET-CLEVIS



ANCHOR SHACKLE



BELL Y-CLEVIS

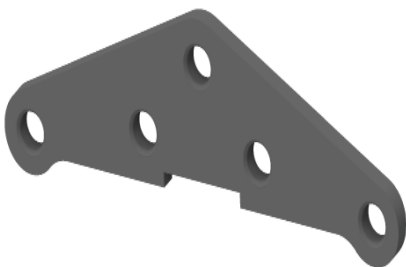

YOKE PLATE



CHAIN LINK Y-CLEVIS



ES

STRAIN HARDWARE

TYPE AQD

Bolted
Strain Clamp

For standard voltage high tension transmission line construction with AAC, ACSR or aluminum alloy conductor.

Type AQDS is a short version that provides additional clearance for substation applications.

Casting Alloy: 356-T6 Aluminum
Clamping Hardware: Galvanized Steel
Cotter Pin: Stainless Steel

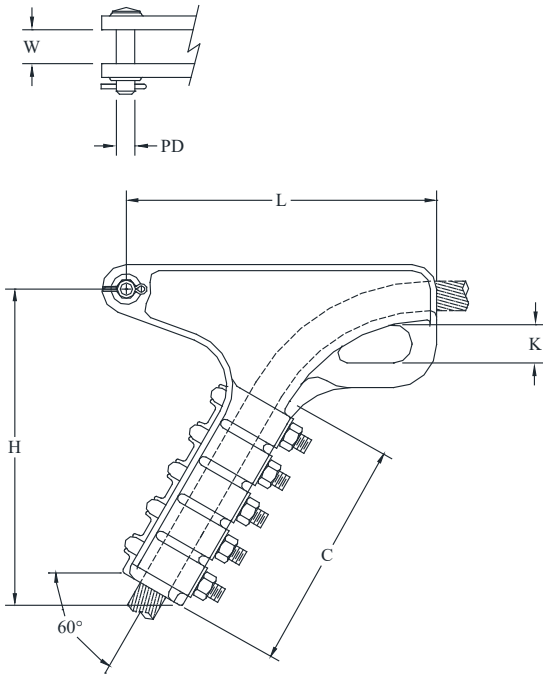

CATALOG NUMBER	DIMENSION - INCHES					
	L	W	H	C	K	PD
AQD-75	8-1/2	7/8	8-7/16	5-7/8	1-1/4	5/8
AQD-120	12-5/8	1-3/8	12-7/8	9-3/8	1-1/2	3/4
AQD-155	14-1/4	1-11/16	16-13/16	12-3/8	1-1/2	3/4
AQDS-155	14-1/4	1-11/16	13-15/16	9	1-1/2	3/4

CATALOG NUMBER	FITTING TYPE	CLAMPING RANGE			ULTIMATE BODY STRENGTH (POUNDS)	U-BOLTS		APPROX. WEIGHT (POUNDS)
		ACSR	AAC	INCHES		NO.	SIZE (IN.)	
AQD-75	None	#2 (7/1) To 397.5 (26/7)	#1 To 397.5	.30 - .75	20,000	4	1/2	4.70
AQD-75-SF	Socket				20,000			5.80
AQD-75-CF	Clevis				20,000			6.30
AQD-120	None	#4/0 (6/1) To 954 (54/7)	250 To 1033.5	.56 - 1.20	30,000	5	5/8	13.20
AQD-120-SF	Socket				30,000			15.00
AQD-120-CF	Clevis				25,000			15.05
AQD-155	None	954 (24/7) To 1780 (84/19)	1100 To 1750	1.18 - 1.63	35,000	5	5/8	16.00
AQD-155-SF	Socket				30,000			17.30
AQD-155-CF	Clevis				25,000			17.80
AQDS-155	None	954 (24/7) To 1780 (84/19)	1100 To 1750	1.18 - 1.63	35,000	4	5/8	14.80
AQDS-155-SF	Socket				30,000			16.05
AQDS-155-CF	Clevis				25,000			16.60

STRAIN HARDWARE

TYPE ASDE

Bolted
Strain Clamp

Casting Alloy: 356-T6 Aluminum
Clamping Hardware: Galvanized Steel
Cotter Pin: Stainless Steel

For standard voltage distribution and light transmission line construction with AAC, ACSR or aluminum alloy conductor.

CATALOG NUMBER	DIMENSIONS - INCHES		
	L	W	K
ASDE-46	7-1/2	3/4	7/8
ASDE-70	9-13/16	3/4	7/8
ASDE-98	11-5/8	1-1/16	15/16
ASDE-155	14-1/2	1-1/16	15/16

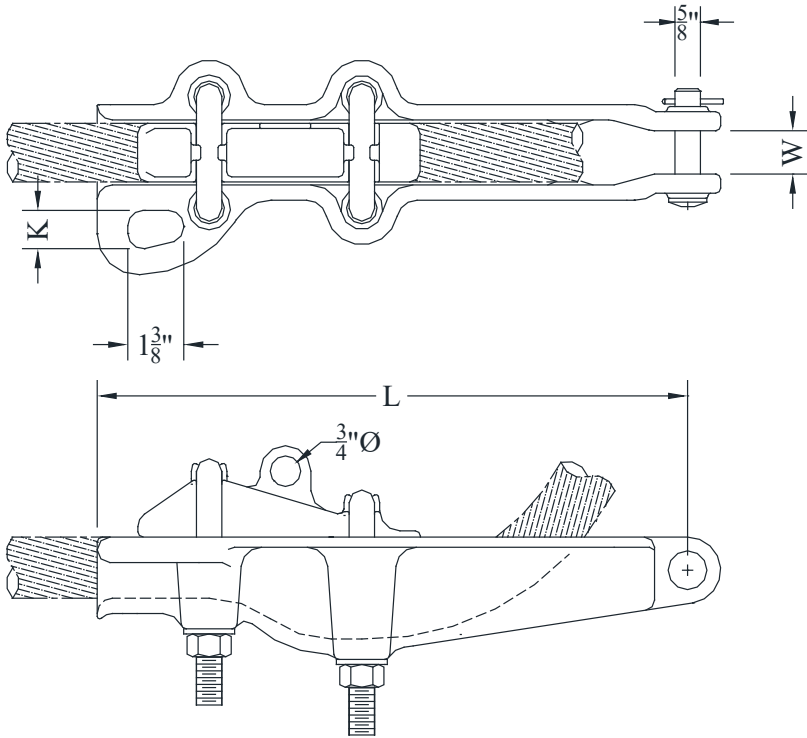

CATALOG NUMBER	FITTING TYPE	CLAMPING RANGE			ULTIMATE BODY STRENGTH (POUNDS)	U-BOLTS		APPROX. WEIGHT (POUNDS)
		ACSR	AAC	INCHES		NO.	SIZE (IN.)	
ASDE-46	None	#6 To #2/0	#6 To #2/0	.18 - .46	6,000	2	3/8	1.65
ASDE-46-SF	Socket							2.80
ASDE-46-CF	Clevis							3.25
ASDE-70	None	#3/0 (6/1) To 336.4 (18/1)	#3/0 To 350	.46 - .70	8,000	2	1/2	2.20
ASDE-70-SF	Socket							3.35
ASDE-70-CF	Clevis							3.80
ASDE-98	None	300 (26/7) To 636 (30/19)	350 To 795	.68 - 1.03	9,000	2	1/2	3.50
ASDE-98-SF	Socket							4.60
ASDE-98-CF	Clevis							5.10
ASDE-155	None	636 To 1590	715.5 To 1800	.98 - 1.55	14,000	2	5/8	8.05
ASDE-155-SF	Socket							9.15
ASDE-155-CF	Clevis							9.65

STRAIN HARDWARE

TYPE FQD

Bolted
Strain Clamp

For dead ending static wire.

Casting Alloy: Galvanized Ductile Iron
Clamping Hardware: Galvanized Steel
Cotter Pin: Stainless Steel

CATALOG NUMBER	DIMENSIONS - INCHES					
	L	W	H	C	K	PD
FQD-65	5	3/4	6	4	1	5/8
FQD-68	5	7/8	8	4-5/8	1-1/4	5/8

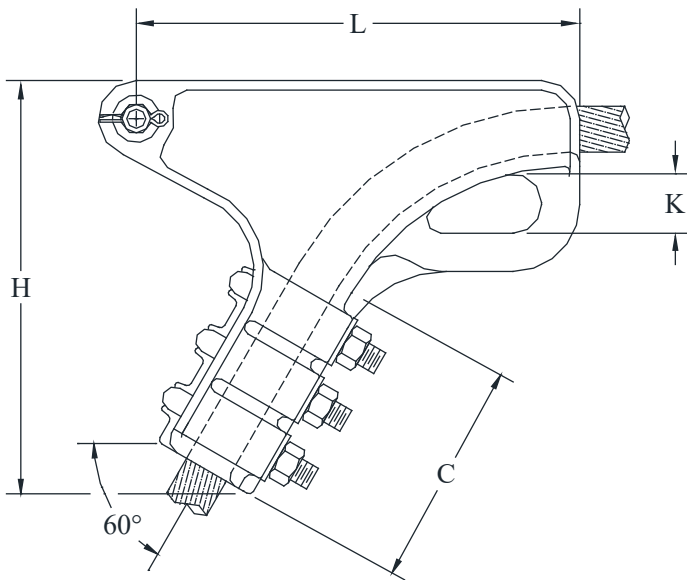
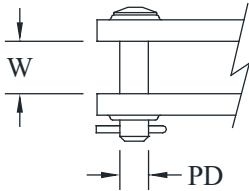

CATALOG NUMBER	FITTING TYPE	CLAMPING RANGE	ULTIMATE BODY STRENGTH (POUNDS)	U-BOLTS		APPROX. WEIGHT (POUNDS)
		INCHES		NO.	SIZE (IN.)	
FQD-65	None	0.16 - 0.55	20,000	2	1/2	3.75
FQD-65-SF	Socket		20,000			5
FQD-65-CF	Clevis		16,000			5.35
FQD-68	None	0.18 - 0.58	20,000	3	1/2	6.55
FQD-68-SF	Socket		20,000			7.65
FQD-68-CF	Clevis		20,000			8.15

STRAIN HARDWARE

TYPE BCS/BCSS

Dead End Strain Clamp
Straight/Quadrant

Add suffix - SF or -CF for socket fitting or clevis fitting.
Example: BCS-2034-SF

Casting Alloy: Aluminum Bronze
Clamping Hardware: Silicon Bronze
Clevis Pin: Galvanized Steel
Cotter Pin: Stainless Steel

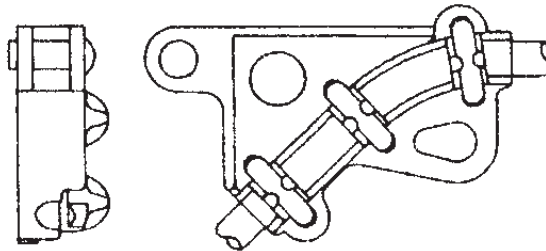

BCS

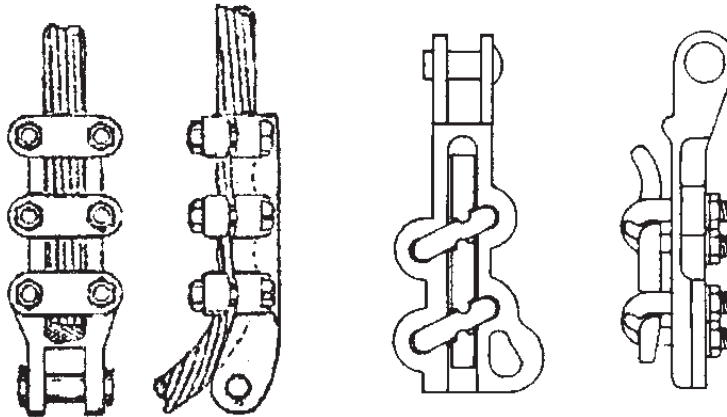

BCSS

CATALOG NUMBER	CONDUCTOR SIZE
BCS-20	4/0 - 500 MCM QUADRANT
BCS-2034	500 - 1000 MCM QUADRANT
BCS-3442	1000 - 1500 MCM QUADRANT
BCS2-2027	(2) - 500 - 750 MCM QUADRANT
BCSS-0814	1/0 STR - 300 MCM STRAIGHT
BCSS-2028	500 - 800 MCM STRAIGHT
BCSS-2734	750 - 1000 MCM STRAIGHT

STRAIN HARDWARE

SOCKET-EYE

Socket eyes can be used for connecting conductor clamping devices to ball and socket type insulators.

Body: Galvanized Ductile Iron
Cotter Pin: Stainless Steel

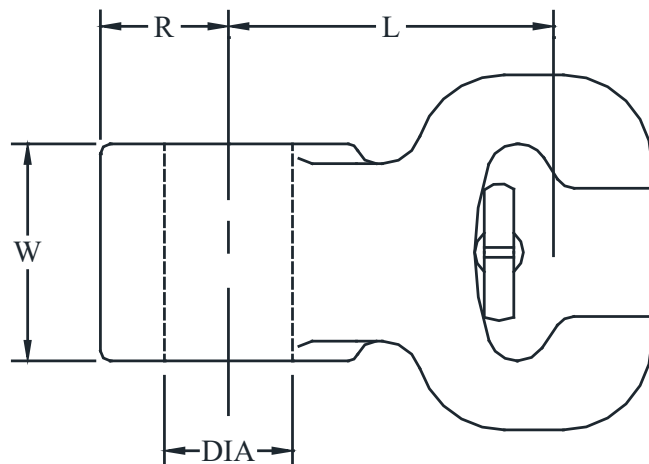

CATALOG NUMBER	ULTIMATE STRENGTH (POUNDS)	DIMENSIONS - INCHES				APPROX. WEIGHT (POUNDS)
		W	R	L	DIA	
AH-1213	20,000	5/8	7/8	2-1/8	11/16	1.11
AH-1209	30,000	1	7/8	2-3/8	13/16	1.85
AH-1206	30,000	1-3/8	13/16	2-3/16	13/16	1.28

CLEVIS-EYE

Clevis eyes can be used for connecting conductor clamping devices to clevis tongue insulators.

Body: Galvanized Ductile Iron
Clevis Pin: Galvanized Steel
Cotter Pin: Stainless Steel

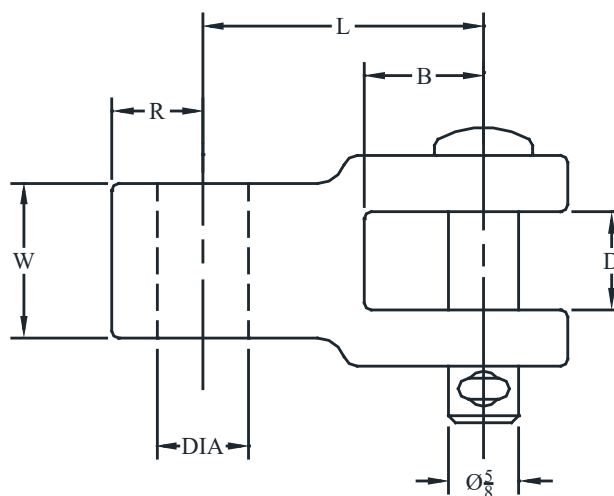

CATALOG NUMBER	ULTIMATE STRENGTH (POUNDS)	DIMENSIONS - INCHES						APPROX. WEIGHT (POUNDS)
		W	R	B	D	L	DIA	
AH-1212	20,000	5/8	5/8	1-1/8	13/16	2-1/2	11/16	1.60
AH-1208	25,000	1-1/8	15/16	1-1/8	7/8	3-1/8	13/16	1.90
AH-1205	25,000	1-3/8	13/16	1-1/8	13/16	3-1/2	13/16	1.85

STRAIN HARDWARE

CLEVIS CLEVIS

For attaching clevis tongue insulators to various associated hardware within an insulator string.

Body: Galvanized Ductile Iron
Clamping Hardware: Galvanized Steel
Cotter Pin: Stainless Steel

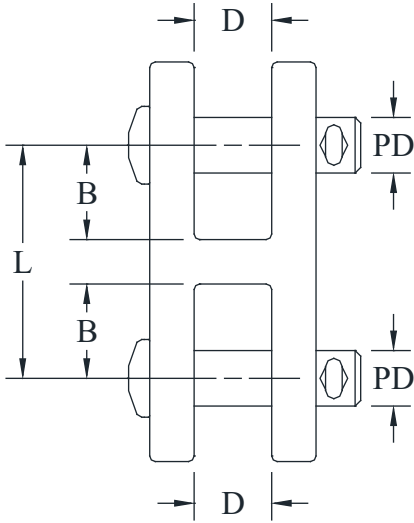

FIG. 1

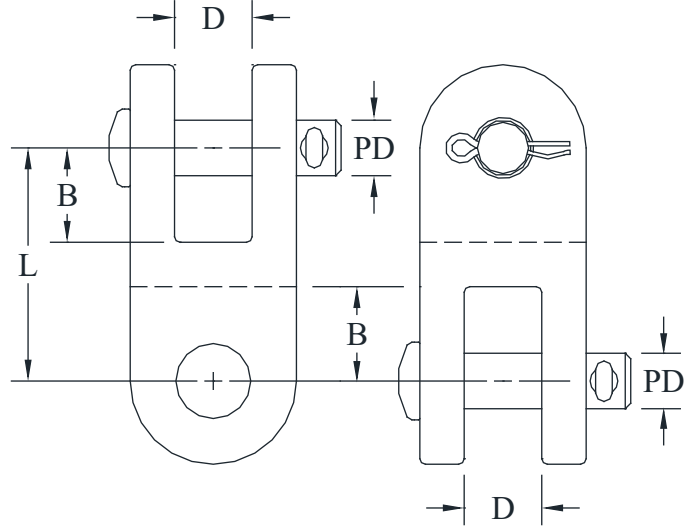

FIG. 2

CATALOG NUMBER	FIG. NO.	ULTIMATE STRENGTH (POUNDS)	DIMENSIONS - INCHES				APPROX. WEIGHT (POUNDS)
			B	D	L	PD	
AH-1224	1	30,000	1-9/16	13/16	3-1/2	5/8	2.50
AH-1225	2	30,000	1-9/16	13/16	3-1/2	5/8	2.50

CHAIN LINK

Used to maintain proper clearance and connect associated hardware within an insulator string.

Material: Galvanized Steel

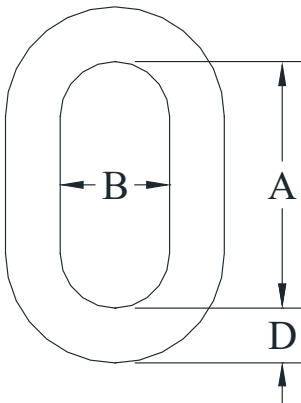

CATALOG NUMBER	ULTIMATE STRENGTH (POUNDS)	DIMENSIONS - INCHES			APPROX. WEIGHT (POUNDS)
		A	B	D	
AH-1226	30,000	2-1/4	1	1/2	0.45

STRAIN HARDWARE

Y-CLEVIS CLEVIS

Body: Galvanized Ductile Iron
Hardware: Galvanized Steel
Cotter Pin: Stainless Steel

For attaching clevis tongue insulators to various associated hardware within an insulator string.

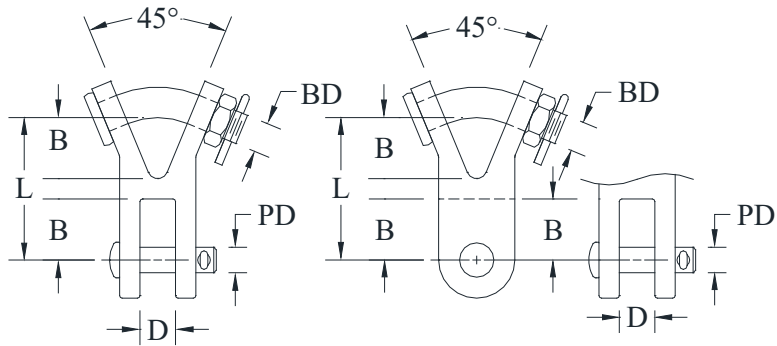

FIG. 1

FIG. 2

CATALOG NUMBER	FIG. NO.	ULTIMATE STRENGTH (POUNDS)	DIMENSIONS - INCHES					APPROXIMATE WEIGHT (POUNDS)
			B	D	L	BD	PD	
AH-1227	1	30,000	1-9/16	13/16	3-5/8	3/4	5/8	1.35
AH-1231	2	30,000	1-9/16	13/16	3-5/8	3/4	5/8	1.90

SOCKET CLEVIS

Body: Galvanized Ductile Iron
Hardware: Galvanized Steel
Cotter Pin: Stainless Steel

Socket clevis can be used for connecting conductor clamping devices to ball and socket type insulators.

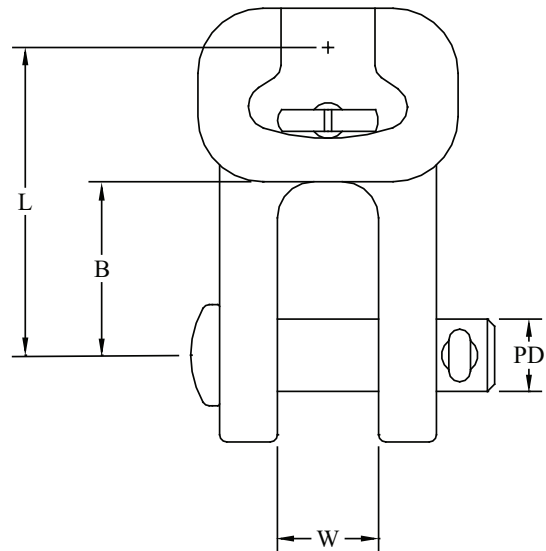

CATALOG NUMBER	ULTIMATE STRENGTH (POUNDS)	DIMENSIONS - INCHES				APPROXIMATE WEIGHT (POUNDS)
		W	B	L	PD	
AH-1258	30,000	1	1-1/2	2-5/8	5/8	2.00

STRAIN HARDWARE

ANCHOR SHACKLE

For attaching associated hardware to the tower pad. Available with clevis pin and cotter pin or clevis bolt, nut and cotter pin.
Add suffix -BNC to catalog number to specify bolt nut and cotter pin.

Body: Galvanized Steel
Clamping Hardware: Galvanized Steel
Cotter Pin: Stainless Steel

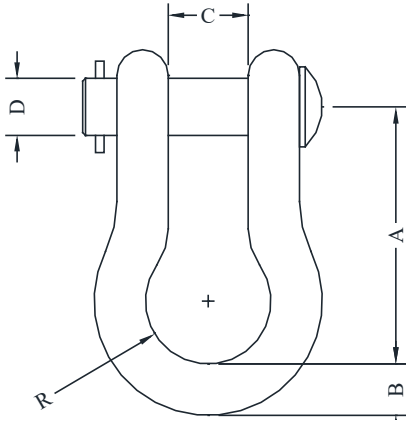

CATALOG NUMBER	ULTIMATE STRENGTH (POUNDS)	DIMENSIONS - INCHES					APPROX. WEIGHT (POUNDS)
		A	B	C	D	R	
AH-1219	30,000	2-13/16	9/16	7/8	5/8	11/16	0.75
AH-1219-BNC	30,000	2-13/16	9/16	7/8	5/8	11/16	1.15
AH-1220	40,000	2-3/4	5/8	1-1/16	3/4	3/4	1.45
AH-1220-BNC	40,000	2-3/4	5/8	1-1/16	3/4	3/4	1.65
AH-1221	50,000	3-1/2	3/4	1-1/4	7/8	1	2.25
AH-1221-BNC	60,000	3-1/2	3/4	1-1/4	7/8	1	2.25

BALL Y-CLEVIS

Used to attach ball and socket insulators to other associated hardware.

Body: Galvanized Steel
Hardware: Galvanized Steel
Cotter Pin: Stainless Steel

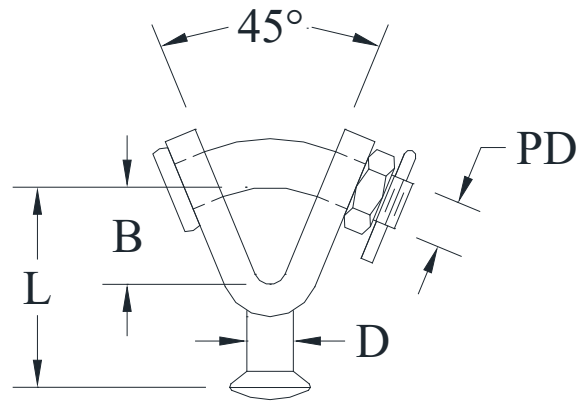

CATALOG NUMBER	ANSI CLASS	ULTIMATE STRENGTH (POUNDS)	DIMENSIONS - INCHES				APPROX. WEIGHT (POUNDS)
			B	D	L	PD	
AH-1222	52-3 & 5	30,000	1-1/2	23/32	3-3/32	3/4	1.90
AH-1223	52-8 & 11	50,000	1-13/16	57/64	3-15/16	7/8	3.30

STRAIN HARDWARE

YOKE PLATES

Yoke plates may be furnished in a variety of shapes, sizes, hole spacings, ultimate strengths, and provisions for mounting corona rings. Contact the manufacturer for any options not shown.

Material: Galvanized Steel

Matching corona rings can be supplied with the yoke plates. Consult manufacturer for further details or unlisted applications.

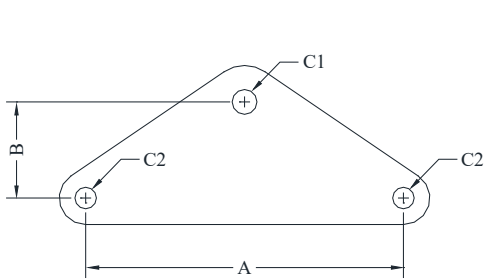

FIG. 1

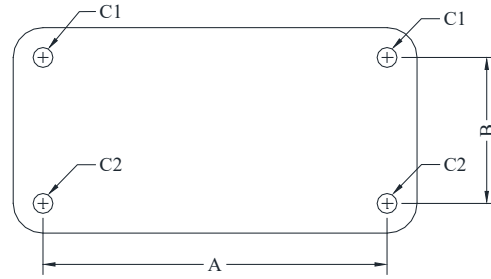

FIG. 2

CATALOG NUMBER	FIGURE NUMBER	ULTIMATE STRENGTH (POUNDS)	DIMENSIONS - INCHES				
			A	B	C1	C2	THICKNESS
BP-2249	1	40,000	18	3-5/8	1-1/4	1-1/4	3/4
BP-2250	1	40,000	13	3-11/16	15/16	11/16	3/4
BP-2257	1	30,000	13	3-5/8	15/16	11/16	5/8
BP-2260	1	30,000	16	3-5/8	1-1/4	1-1/4	3/4
BP-2276	1	50,000	18	5	1-1/8	1-1/4	3/4
BP-2280	1	30,000	9	6	1-1/4	1-1/4	3/4
BP-2314	1	30,000	24	5-7/8	1-1/8	1-1/4	3/4
BP-2327	1	30,000	18	5	1-1/8	1-3/4	3/4
BP-2349	1	30,000	13	3-3/4	15/16	11/16	3/4
BP-2352	1	30,000	10	3	3/4	3/4	3/4
BP-2356	1	30,000	18	9	15/16	15/16	5/8
BP-2374	1	30,000	8-11/16	3	3/4	3/4	3/4
BP-2402	1	30,000	8	3-1/2	15/16	15/16	3/4
BP-2491	1	30,000	18	5	1-1/4	1-1/4	3/4
BP-2492	2	30,000	13	5-1/2	3/4	3/4	3/4
BP-2519	1	30,000	18	3-5/8	15/16	11/16	3/4
BP-2520	2	30,000	18	5-1/2	3/4	3/4	3/4
BP-2531	2	30,000	18	6	15/16	15/16	3/4
BP-2547	1	30,000	12	3-5/8	15/16	13/16	3/4
BP-2548	1	30,000	18	5	1-1/8	1-1/4	3/4
BP-2553	2	30,000	18	5-1/2	15/16	13/16	3/4
BP-2555	1	30,000	16	4-1/4	11/16	11/16	5/8
BP-2565	1	30,000	12	4-1/2	1-1/4	1-1/4	5/8
BP-2569	1	30,000	18	6-1/2	1-1/8	1-1/4	3/4

Lifting holes and mounting holes for corona rings are not shown in this layout. For detailed drawings that indicate all features please contact the manufacturer.

STRAIN HARDWARE

TYPE ES

Extension
Strap

Used within a transmission assembly to attach hardware and maintain proper clearances.

The extension straps can be manufactured to your specifications. Consult manufacturer for further details or unlisted applications.

Material: Galvanized Steel

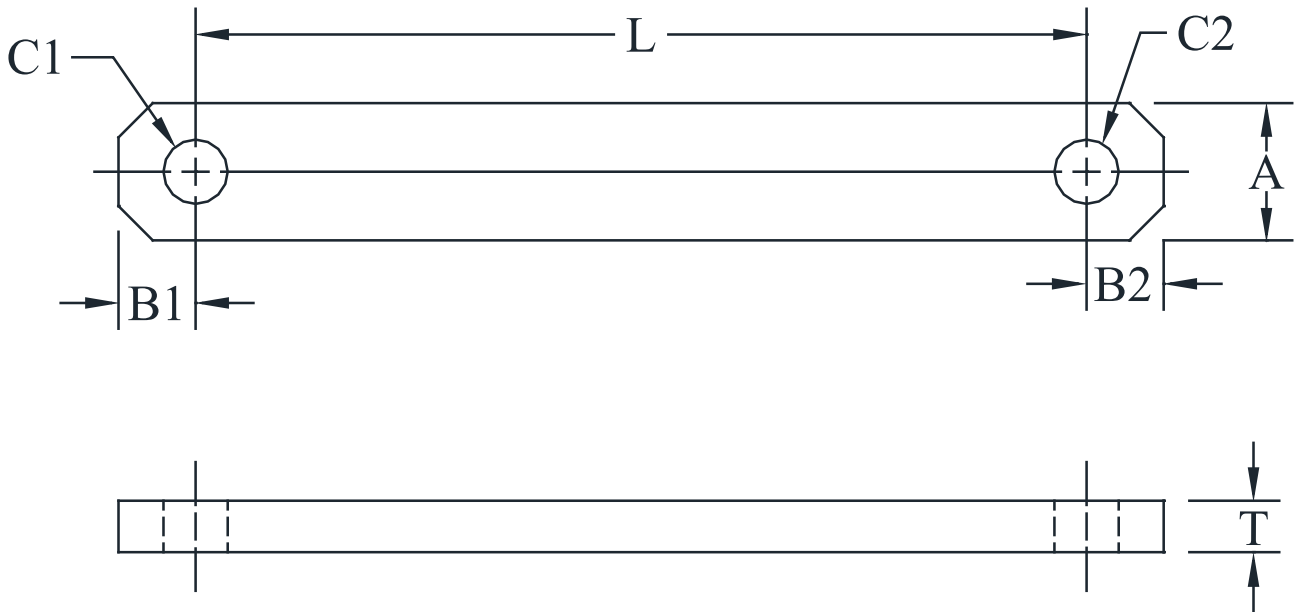

CATALOG NUMBER	ULTIMATE STRENGTH (POUNDS)	DIMENSIONS - INCHES						
		A	B1	B2	C1	C2	L	T
ES-10-69-L	10,000	1-1/2	3/4	3/4	11/16	11/16	PLEASE SPECIFY	1/4
ES-20-69-L	20,000	1-1/2	7/8	7/8	11/16	11/16		1/2
ES-30-94-L	30,000	2	1-1/8	1-1/8	15/16	15/16		3/4
ES-40-94-L	40,000	2-1/2	1-1/2	1-1/2	15/16	15/16		3/4
ES-60-113-L	60,000	2-1/2	2	2	1-1/8	1-1/8		1
ES-80-125-L	80,000	3	2	2	1-1/4	1-1/4		1

BIG ENOUGH TO SERVE YOUR NEEDS ... **SMALL ENOUGH TO CARE**

At SEFCOR, our motto is "THE INDUSTRY LEADER IN SERVICE TO OUR CUSTOMERS." We are dedicated and committed to responding promptly to our customers' needs. Whether there is a question, a problem, or a request for quotation, SEFCOR will always respond quickly.

SEFCOR specializes in quick shipments with a proven record of on-time deliveries. We pride ourselves in knowing that our customers have learned to count on our dependability to produce on time.

SEFCOR connectors are designed for simple installation and optimum performance for all applications and service conditions.

SEFCOR connectors are designed, manufactured and tested per the most current NEMA and ANSI Standards. SEFCOR has additional capability to design and manufacture to special requirements and applications.

In addition to a full line of connectors, SEFCOR offers a complete line of electrical connectors; bolted, welded and ground connectors; aluminum or copper; tubular, cable flat or IWCB bus. Products range from ground connectors to corona free EHV substation connectors.

Accessories include fabricated aluminum and bronze assemblies, "A" Frame assemblies, corona rings, voltage grading rings, laminated straps, flexible braid and bus fabrication. Field substation bus welding service also available.

SEFCOR reserves the right to make changes in specifications shown herein, or to add improvements, at any time, without notice or obligation.





SERVICE • QUALITY • INNOVATION • TECHNICAL SUPPORT

1150 Uniform Road
Griffin, Georgia 30224
Telephone: 770-227-8297
Fax: 770-229-5120
frontdesk@sefcor.com
www.sefcor.com

Made In The U.S.A.